

PRODUCT SPECIFICATION

VOLITO

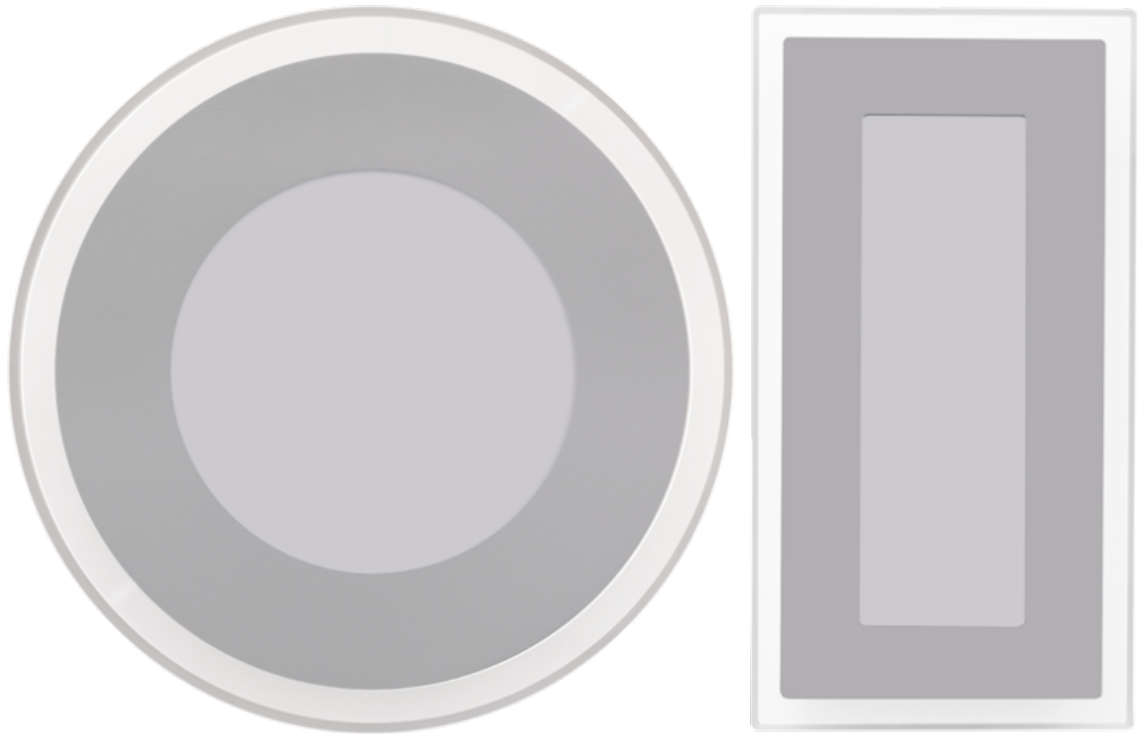

INTRODUCTION

Combining efficiency and flexibility with a striking aesthetic, the Volito offers the ideal solution to those wishing to create drama and impact in any space. With a milled clear surround with bevelled edge the Volito produces a halo effect which contrasts against the grey housing and high transmission central opal diffuser to produce concentric contrasting rings with differing visual effects.

The Volito has been designed to ensure that visual effect does not compromise performance, efficiency and flexibility. With a range of lumen outputs, lithium emergency and dimming options, as well as controls solutions including wireless connectivity, the Volito can be specified in various combinations to suit the requirements of the installation and to integrate with all common controls systems. Circular or rectangular versions and a range of colour temperature options further enhance the flexibility of this luminaire whilst a range of integral microwave sensors allow for presence detection and wireless grouping allowing simultaneous triggering of luminaires and providing enhanced energy savings.



CE IP20 TM21: L90>60K HOURS / L80>90K HOURS 3 STEP MACADAM ELLIPSE

APPLICATION

- Commercial / Offices
- Corridor

- › Education
 - › Healthcare / Social Housing
 - › Hotel / Leisure
 - › Retail
 - › Stairwell
-

SPECIFICATION

CONSTRUCTION

- › Housing: 0.6mm CR4 steel
- › Housing: Injection moulded polycarbonate
- › Finish: Polyester powder painted BS 00E55 matt white 60% gloss
- › Finish: Matt white
- › Diffuser: 2mm high transmission opal polycarbonate TP(a) rated
- › IP20
- › Injection moulded polycarbonate housing (circular).

PERFORMANCE

- › 3SCDM Three step Macadams ellipse
- › TM21: L90>60K Hours / L80>90K Hours
- › Up to 109 luminaire lumens per circuit Watt.

ENVIRONMENTAL

- › Designed to allow simple replacement of components with commonly available tools in compliance with the Eco Design Directive, please see the installation leaflet for maintenance instructions.
- › Powered by European branded drivers and emergency modules ensuring replacement parts are easily sourced.
- › Every luminaire is labelled with a unique ID number allowing easy identification of spare parts for the lifetime of the product.
- › Contains no single use plastics or polystyrene packaging.
- › Supplied in plain card boxes with paper tape ensuring packaging is easily recycled.
- › Designed to allow simple disassembly for end of life recycling.
- › UK based manufacturing providing local support throughout the product lifetime and minimising transportation miles.

EMERGENCY

- › Available with optional standard, self test and autotest integral emergency with lithium batteries for extended warranty and lifetime.
- › Optional Reacta-Link wireless emergency for automated centralised reporting.

- Optional Reacta-Control wireless emergency for automated centralised reporting.

CONTROL

- Optional compatibility with a range of dimming systems including DALI, DSI and Switch Dimming
- Optional Integral R25 microwave presence and bright out sensor
- Optional integral Reacta-Link for integration with Reacta-Link wireless installations
- Optional integral Reacta-Control for integration with Reacta-Control wireless installations

INSTALLATION

- Suitable for conduit installation
- Suitable for surface installation
- Retrofit in existing luminaires

VARIATIONS

- 6mm Milled clear polycarbonate halo effect diffuser surround.

IMAGES

PRODUCT IMAGES



Volito Round Grey



Volito Round Dark Grey



Volito Round Grey



Volito Round Dark Grey

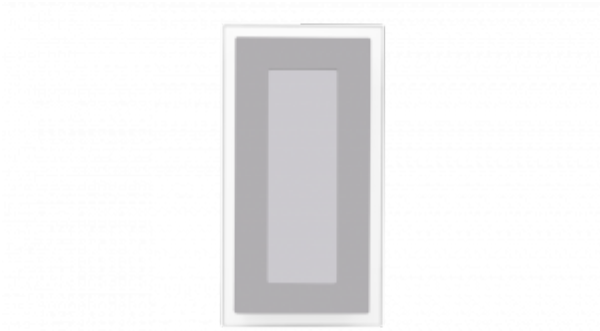

Volito Rectangle Grey

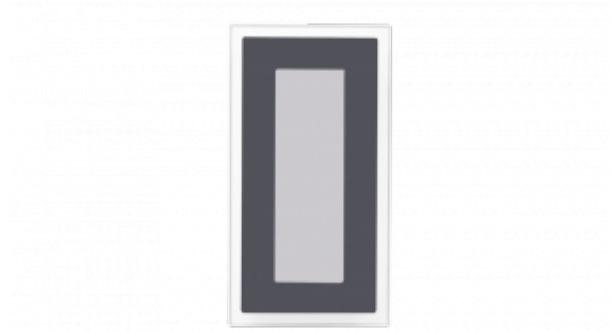

Volito Rectangle Dark Grey



Volito Rectangle Grey



Volito Rectangle Dark Grey



Volito Round Grey Lit



Volito Rectangle - Dark Grey - Lit

PROJECT IMAGES





TECHNICAL

>

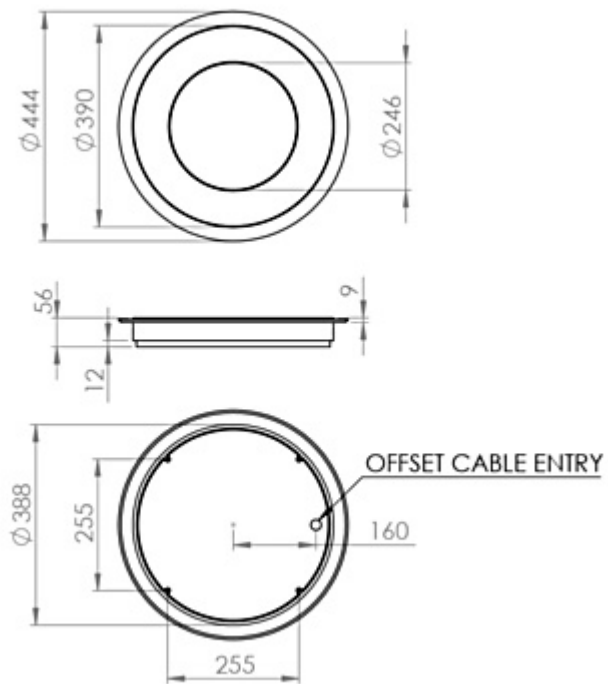

Volito Circular

>

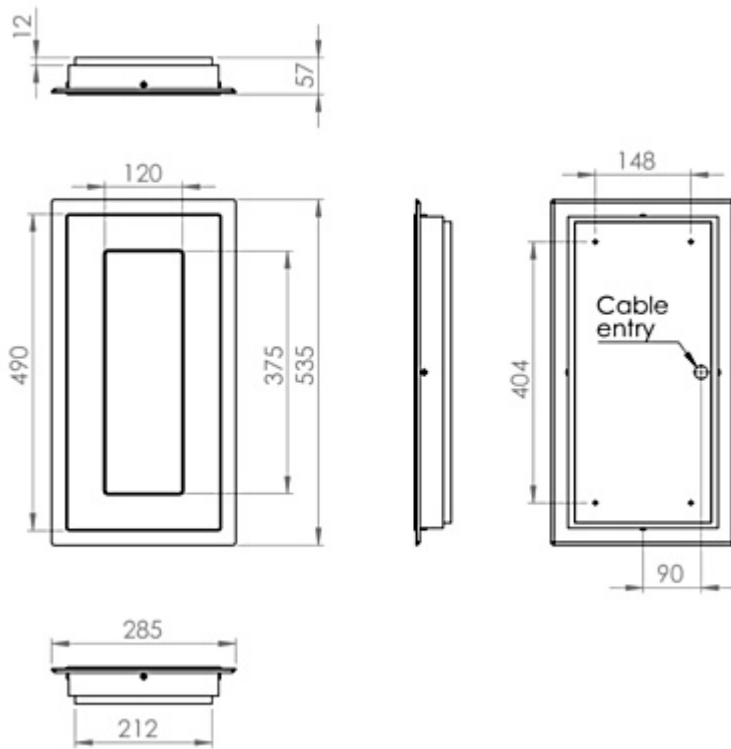

Volito Rectangular

WARRANTY

At Dextra our commitment to service has been at the forefront throughout our history spanning more than forty years in the UK lighting market. Our service ethos extends beyond design and delivery, we believe supporting your installation throughout the warranty period is equally crucial, whilst the strength and longevity of Dextra Group provides peace of mind that our warranty will be supported throughout.

The Dextra range is supplied with a five year warranty commencing from the date of delivery. During the first three years defects will be repaired on site and the warranty will include both parts and labour. For the final two years drivers, emergency modules, wireless modules, sensors and LED circuits will be supplied free of charge to replace defective components, labour and other associated costs are not included.

Certain ranges and components are subject to exemptions:

- Lithium batteries are provided with a five year warranty. During the first three years defects will be repaired on site and the warranty will include both parts and labour. For the final two years replacement batteries will be supplied free of charge to replace defective components. Five year warranty became effective as of 03/02/25, Lithium emergency luminaires supplied prior to this date are supported with a three year on site warranty only. Labour and other associated costs are not included. Nickel Metal Hydride and Nickel Cadmium batteries are provided with a one year warranty for parts and labour.

- Emergency luminaires including AME LED, EXI LED, EXI2 LED, EXI Track, HBE LED, HBE2 LED, OAT2 LED, OEZ LED and Twinspot with Nickel Metal Hydride batteries are supplied with a one year warranty for parts and labour. Lithium variants of these ranges are supplied with a three year warranty for parts and labour with the exception of the AME2, EXI3, HBE3 and TWS IP65 L7 ranges which are supplied with a one year parts and labour warranty. TWS IP65 L7 in autotest and wireless variants are supplied with the standard three year lithium battery warranty.
- Protec Micro, PTECF7 Fire Rated Downlights, Serenus and the Opus Sconce are provided with a five year replacement luminaire only warranty. Protec FR Fire Rated Downlights are provided with a 2 year replacement luminaire only warranty.
- Controls systems such as standalone sensors, switches, marshalling boxes and cabling are provided with a one year warranty for both parts and labour. DALI control systems are provided with a two year warranty for both parts and labour.
- LEDextra ranges are supplied with a three year parts or replacement luminaire only warranty with the exception of the IMPR RGBW, the Runway RGBW, the MOD RGBW, Tanek RGBW and the DexRing. These five ranges are supplied with our standard five year warranty during which defects within the first three years will be repaired on site and the warranty includes both parts and labour. For the final two years free of charge replacement components only will be supplied to rectify any failures but labour and other associated costs are not included.
- LEDEX ranges are supplied with a three year replacement luminaire only warranty.
- The Decorative Pendant ranges, Bebo, Dene, Nova, Fino and Stix are supplied with a 3 year replacement luminaire only warranty.

All warranties are subject to correct use of the product and will be invalidated by misuse, for example incorrect installation, unsuitable environmental conditions or incorrect maintenance. It is the duty of the customer to ensure that all the fault lies with the luminaire prior to requesting replacement parts or site repairs. In the event that no defect is found with the product our costs for attending site will be recharged to the customer and credit will not be issued against returned products. No consequential losses incurred resulting from any defect with our product will be reimbursed.

Given the nature of LED technology a small percentage of LEDs may fail during the lifetime of a luminaire, this does not cause a reduction in lumen output. As such LED luminaires are only deemed to be faulty for warranty purposes when in excess of ten percent of LEDs have failed in a single luminaire.

On site repair of products under warranty will be undertaken during normal working hours, 9am to 5pm Monday to Friday, and will require unrestricted access to luminaires. Where required Dextra will provide access equipment to carry out repairs at height, should luminaires have been installed in locations where reasonable provision for maintenance access has not been made we reserve the right to supply replacement product only. On site warranty repairs will only be undertaken on the mainland of the UK and Ireland, in all other locations replacement product only will be provided.

If you require any assistance with regards to our products please contact our Customer Services department on 01747 858100.

ORDER CODES

LUMINAIRE

| Code | Description | Power | Llm/W |
|------------|---|-------|-------|
| VOL L15 CI | Volito, 1,191llm, Opal Diffuser, Light Grey Bezel, Circular, Colour 84 | 10.7W | 111 |
| VOL L20 CI | Volito, 1,588llm, Opal Diffuser, Light Grey Bezel, Circular, Colour 84 | 14.5W | 109 |
| VOL L30 CI | Volito, 2,382llm, Opal Diffuser, Light Grey Bezel, Circular, Colour 84 | 23.1W | 103 |
| VOL L15 RE | Volito, 1,032llm, Opal Diffuser, Light Grey Bezel, Rectangular, Colour 84 | 11.5W | 89 |
| VOL L20 RE | Volito, 1,376llm, Opal Diffuser, Light Grey Bezel, Rectangular, Colour 84 | 14.8W | 92 |
| VOL L30 RE | Volito, 2,064llm, Opal Diffuser, Light Grey Bezel, Rectangular, Colour 84 | 20.9W | 98 |

DIMMING

| Code | Description |
|------|---|
| A | DALI Digital Addressable Lighting Interface |
| S | Switch Dimming |
| D | DSI Digital Dimming |
| C | Bi-Level Dimming For Standalone Switched Sensor |

CONTROL

| Code | Description |
|-------|---|
| R25E | Reacta 25, Presence & Bright Out, On / Off, 2.5-4M |
| R25C* | Reacta 25, Presence & Bright Out, Bi-Level Dimming, 2.5-4M |
| RLM | Reacta-Link, Wireless, Presence & Bright Out, 2.5-4M |
| RC | Reacta-Control, Wireless Enabled Luminaire |
| RCMC* | Reacta-Control, Presence & Bright Out, Bi-level Dimming, 2.5-4M |
| RCME | Reacta-Control, Presence & Bright Out, On / Off, 2.5-4M |

[Please click here for full details on our wireless controls.](#)

*Bi-Level Dimming will only dim the luminaire to 10% during absence and brightout, it will not turn the luminaire off.

EMERGENCY

| Code | Description |
|-------|---|
| LE3 | Lithium Standard Emergency 3 Hour |
| LS3 | Lithium Selftest Emergency 3 Hour |
| LA3 | Lithium Autotest Emergency 3 Hour |
| LSTR | Lithium Reacta-Link Emergency 3 Hour |
| LA3RC | Lithium Reacta-Control Emergency 3 Hour |

MISCELLANEOUS

| Code | Description |
|------|--|
| C** | Select Colour Temperature and Rendering: C83, C84, C85, C865, C93, C94 |
| DG | Dark Grey Bezel |
| LSF | Low Smoke Zero Halogen |

220-240V / 50-60Hz

IP20

IK09



WARNING: Luminaire must be earthed. Risk of electric shock from LED boards if operated with cover removed. Installation / operation outside of luminaires intended scope invalidates warranty. Suitable only for domestic / light industrial / industrial applications within the scope of EN55015. Tested to compliance with BSEN 60598: specification for general requirements and tests. Must be installed by a suitably qualified person in accordance with all relevant legislation. Ambient operating temperature of 0°C to 25°C. If maximum operating temperature is exceeded luminaire will automatically dim / switch off. Terminal blocks are rated to 16A unless stated otherwise. The light source contained in this luminaire shall only be replaced by the manufacturer or his service agent or a similar qualified person. **LUMINAIRES WITH EMERGENCY PACK:** When supply is isolated battery output terminals may be live if battery is connected. Isolate mains and battery before servicing. Emergency luminaires require unswitched live connection taken from same phase as switched supply. When unswitched supply is connected status indicator illuminates green, when unswitched supply is disconnected indicator extinguishes and luminaire operates in emergency mode. 24 hour charge period required before undertaking full discharge test. Emergency test sheets provided should be used to record all emergency tests. Batteries should be replaced when 3 hour duration is not met. Excessive switching of permanent live may result in premature battery failure. Battery electrolyte can be harmful to eyes / open wounds, do not puncture, if electrolyte touches skin / eyes flush with water. Do not incinerate batteries.

| Terminal Labelling: | |
|---------------------|--------------------------------|
| Power | |
| L1 | Switched Live |
| E | Earth |
| N | Neutral |
| Emergency | |
| L2 | Unswitched Live |
| DA/AT3 | DALI Autotest |
| DA/AT3 | DALI Autotest |
| Dimming | |
| -/D1/DA | Analogue/DSI/DALI |
| +/D2/DA | Analogue/DSI/DALI |
| L3 | Switch Dim / Corridor Function |

1.

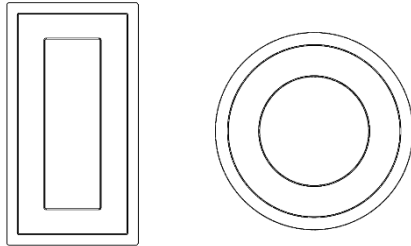

Available in two forms (rectangular or circular).
Installation process will be the same for either shape.

WALL MOUNT ONLY!

2.

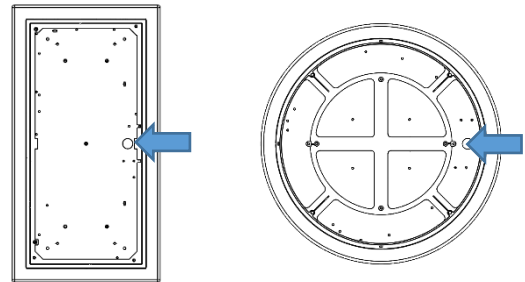

IMPORTANT

Cable entry is offset from the centre of the fitting.

Rectangular = **90mm** from centre

Circular = **160mm** from centre

3.

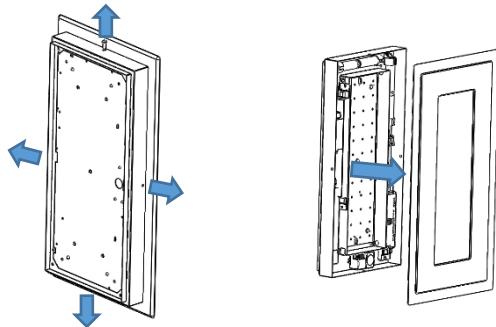

Unscrew the 4 sidewall fixing screws, then remove the front diffuser section from the housing.

4.

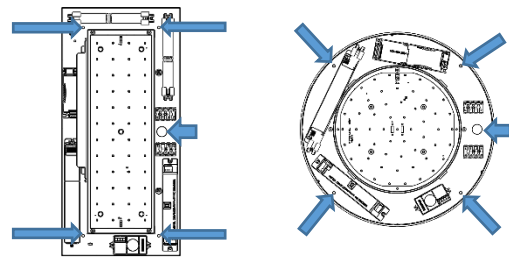

Bring the power lead through the cable entry hole. Then screw the housing to the wall using the fixing points.

Wall Mounted Orientation:

Cable entry hole to be in the 3 o'clock position.

5.

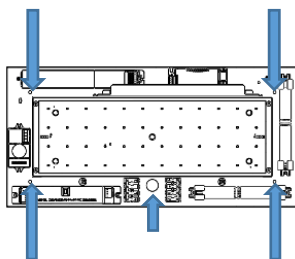

Rectangular – If mounting the fitting horizontally, cable entry hole to be in the 6 o'clock position. This will ensure that the emergency indicator is visible.

6.

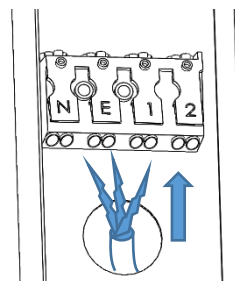

Make the electrical connection to the terminal block.

Volito Installation

7.

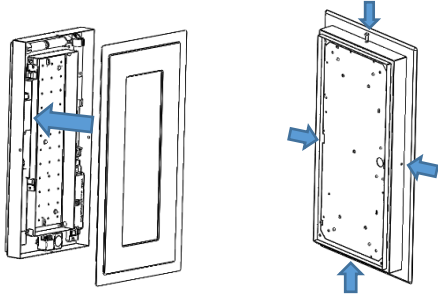

Rectangular – (for circular fitting skip to step 7 & 8)
Offer the diffuser up to the housing
(Fittings with sensors can be connected at this point).
Secure in place with the 4 fixing screws.

8.

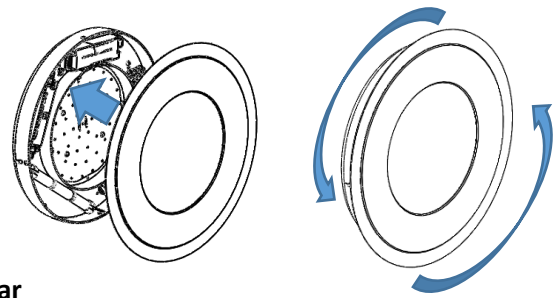

Circular
Offer diffuser up to housing. Rotate Diffuser anti clockwise until you hit the stop and the fixing holes have aligned.

9.

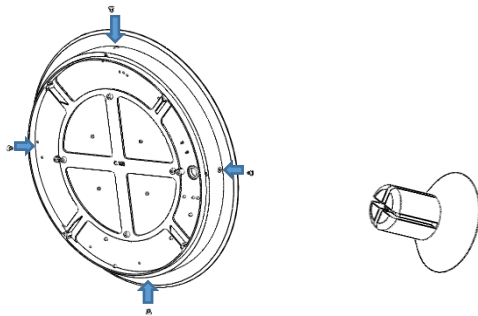

Secure the diffuser in place using the 4 white plastic push rivets supplied (bagged separately).

10.

Maintenance

- 1 Disconnect luminaire before undertaken maintenance or cleaning.
- 2 Cleaning should be undertaken on external parts of the luminaire only using a slightly damp lint free cloth.
- 3 To access rectangular Volito use an Allen Key to remove all screws from fitting then remove front diffuser.
- 4 To access circular Volito remove plastic rivets using a flat head screwdriver, then twist to diffuser to remove.
- 5 Use a pan pozi screwdriver to remove components.
- 6 Please contact Dextra for assistance with spare component supply.

