



PRODUCT SPECIFICATION

TORRENT



INTRODUCTION

Food production areas have always presented a unique challenge for luminaire designers to ensure both effective thermal management in high ambient temperatures and to address the critical issues of cleanliness and IP protection with minimal dirt and dust traps. As a result of these difficulties, options for lighting such arduous applications have been limited and do not always provide optimal energy efficiency and a high quality lit environment for employees. The Torrent offers an LED solution capable of operating in areas with temperatures up to 50°C with an IP65 rating and smooth curved design minimising the risk of dirt accumulating on the luminaire. The Torrent is constructed with die-cast aluminium end caps and extruded aluminium heat sink with high transmission opal diffuser providing a robust construction to give a long life luminaire despite high temperatures and repeated wash-downs.

The LED source not only provides excellent energy efficiency but also eliminates glass and mercury from food environments minimising contamination risk in case of an accident. These benefits are combined with excellent energy efficiency and minimal maintenance ensuring that a quick return on investment can be achieved in most applications. With a wide range of lumen outputs for both 50°C and 25°C ambient temperatures in triple pod variants for high level applications and single pod variants to replace traditional non corrosive style luminaires in lower level applications the Torrent can be tailored to suit the needs of your application whilst offering excellent energy saving against HID and fluorescent luminaires.



CE IP65 TM21: L90>60K HOURS / L80>90K HOURS 3 STEP MACADAM ELLIPSE

APPLICATION

- › Food / Clean Area
- › Industrial / Manufacturing
- › Warehouse / Storage

SPECIFICATION

CONSTRUCTION

- › Housing: Extruded aluminium
- › Finish: Mill finish aluminium
- › Endcaps: High pressure die cast aluminium
- › Diffuser: 2mm extruded high transmission opal polycarbonate
- › IP65
- › Curved design with no dirt or dust traps for food production applications.
- › Includes a range of variants suited for operation at 50°C ambient temperatures.

PERFORMANCE

- › Part L2 compliant
- › 3SCDM Three step Macadams ellipse
- › TM21: L90>60K Hours / L80>90K Hours
- › Up to 129 luminaire lumens per circuit Watt.

ENVIRONMENTAL

- › Designed to allow simple replacement of components with commonly available tools in compliance with the Eco Design Directive, please see the installation leaflet for maintenance instructions.
- › Powered by European branded drivers and emergency modules ensuring replacement parts are easily sourced.
- › Every luminaire is labelled with a unique ID number allowing easy identification of spare parts for the lifetime of the product.
- › Contains no single use plastics or polystyrene packaging.
- › Supplied in plain card boxes with paper tape ensuring packaging is easily recycled.
- › Designed to allow simple disassembly for end of life recycling.

- ▶ UK based manufacturing providing local support throughout the product lifetime and minimising transportation miles.

EMERGENCY

- ▶ Available with optional standard, self test and autotest integral emergency with lithium batteries for extended warranty and lifetime.
- ▶ Optional Reacta-Link wireless emergency for automated centralised reporting.
- ▶ Optional Reacta-Control wireless emergency for automated centralised reporting.

CONTROL

- ▶ Optional compatibility with a range of dimming systems including DALI, DSI and Switch Dimming
- ▶ Optional integral Reacta-Link for integration with Reacta-Link wireless installations

INSTALLATION

- ▶ Suitable for suspended installation
- ▶ Suitable for surface installation

VARIATIONS

- ▶ Available with a wide range of colour temperatures and renderings
- ▶ Available in a range of housing sizes and lumen outputs

IMAGES

PRODUCT IMAGES



Torrent Triple



Torrent Single

TECHNICAL

▶

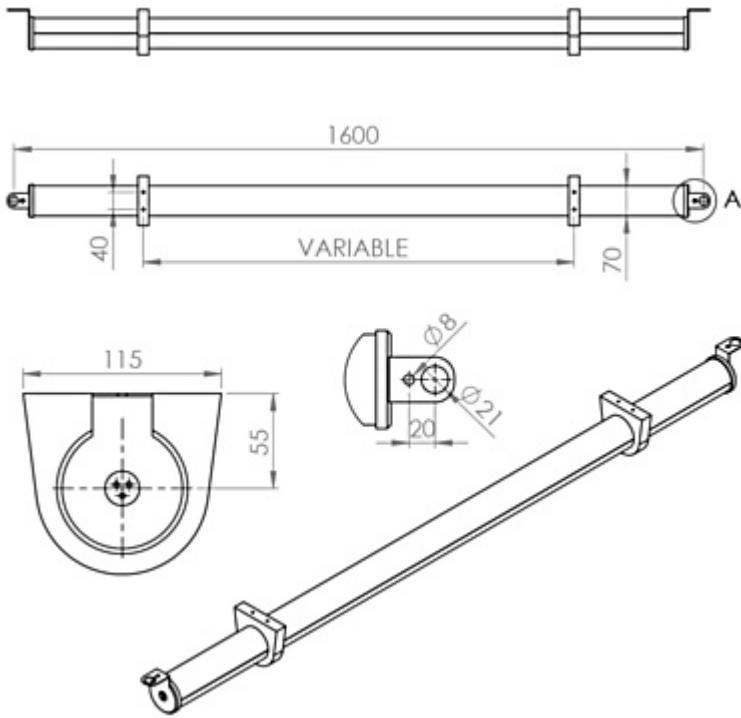

Torrent Single 1600mm

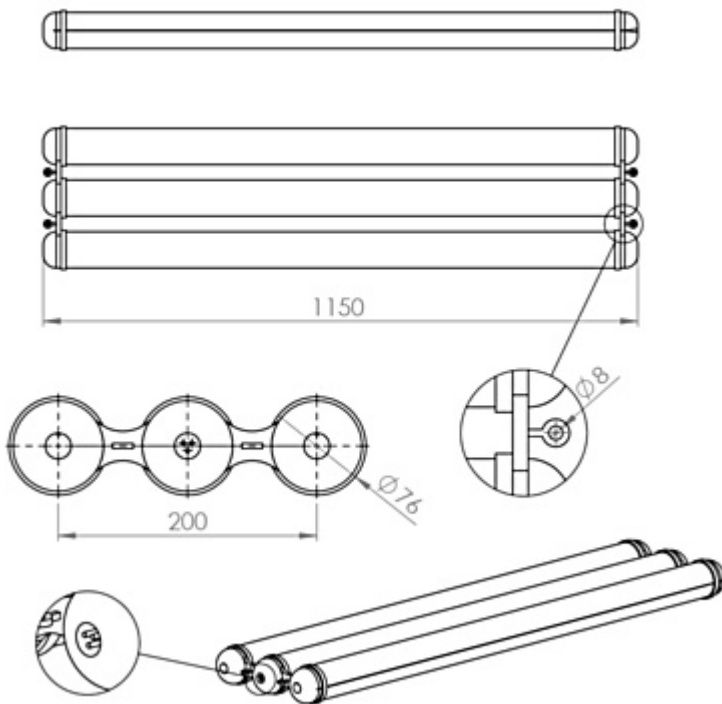

Torrent Triple 1150mm

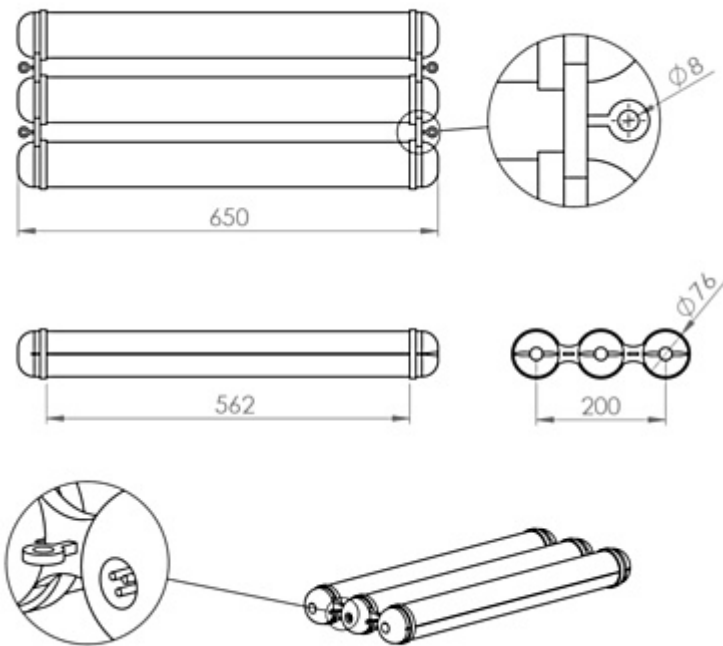

Torrent Triple 650mm

WARRANTY

At Dextra our commitment to service has been at the forefront throughout our history spanning more than forty years in the UK lighting market. Our service ethos extends beyond design and delivery, we believe supporting your installation throughout the warranty period is equally crucial, whilst the strength and longevity of Dextra Group provides peace of mind that our warranty will be supported throughout.

The Dextra range is supplied with a five year warranty commencing from the date of delivery. During the first three years defects will be repaired on site and the warranty will include both parts and labour. For the final two years drivers, emergency modules, wireless modules, sensors and LED circuits will be supplied free of charge to replace defective components, labour and other associated costs are not included.

Certain ranges and components are subject to exemptions:

- Lithium batteries are provided with a five year warranty. During the first three years defects will be repaired on site and the warranty will include both parts and labour. For the final two years replacement batteries will be supplied free of charge to replace defective components. Five year warranty became effective as of 03/02/25, Lithium emergency luminaires supplied prior to this date are supported with a three year on site warranty only. Labour and other associated costs are not included. Nickel Metal Hydride and Nickel Cadmium batteries are provided with a one year warranty for parts and labour.

- Emergency luminaires including AME LED, EXI LED, EXI2 LED, EXI Track, HBE LED, HBE2 LED, OAT2 LED, OEZ LED and Twinspot with Nickel Metal Hydride batteries are supplied with a one year warranty for parts and labour. Lithium variants of these ranges are supplied with a three year warranty for parts and labour with the exception of the AME2, EXI3, HBE3 and TWS IP65 L7 ranges which are supplied with a one year parts and labour warranty. TWS IP65 L7 in autotest and wireless variants are supplied with the standard three year lithium battery warranty.
- Protec Micro, PTECF7 Fire Rated Downlights, Serenus and the Opus Sconce are provided with a five year replacement luminaire only warranty. Protec FR Fire Rated Downlights are provided with a 2 year replacement luminaire only warranty.
- Controls systems such as standalone sensors, switches, marshalling boxes and cabling are provided with a one year warranty for both parts and labour. DALI control systems are provided with a two year warranty for both parts and labour.
- LEDextra ranges are supplied with a three year parts or replacement luminaire only warranty with the exception of the IMPR RGBW, the Runway RGBW, the MOD RGBW, Tanek RGBW and the DexRing. These five ranges are supplied with our standard five year warranty during which defects within the first three years will be repaired on site and the warranty includes both parts and labour. For the final two years free of charge replacement components only will be supplied to rectify any failures but labour and other associated costs are not included.
- LEDEX ranges are supplied with a three year replacement luminaire only warranty.
- The Decorative Pendant ranges, Bebo, Dene, Nova, Fino and Stix are supplied with a 3 year replacement luminaire only warranty.

All warranties are subject to correct use of the product and will be invalidated by misuse, for example incorrect installation, unsuitable environmental conditions or incorrect maintenance. It is the duty of the customer to ensure that all the fault lies with the luminaire prior to requesting replacement parts or site repairs. In the event that no defect is found with the product our costs for attending site will be recharged to the customer and credit will not be issued against returned products. No consequential losses incurred resulting from any defect with our product will be reimbursed.

Given the nature of LED technology a small percentage of LEDs may fail during the lifetime of a luminaire, this does not cause a reduction in lumen output. As such LED luminaires are only deemed to be faulty for warranty purposes when in excess of ten percent of LEDs have failed in a single luminaire.

On site repair of products under warranty will be undertaken during normal working hours, 9am to 5pm Monday to Friday, and will require unrestricted access to luminaires. Where required Dextra will provide access equipment to carry out repairs at height, should luminaires have been installed in locations where reasonable provision for maintenance access has not been made we reserve the right to supply replacement product only. On site warranty repairs will only be undertaken on the mainland of the UK and Ireland, in all other locations replacement product only will be provided.

If you require any assistance with regards to our products please contact our Customer Services department on 01747 858100.

ORDER CODES

LUMINAIRE

Triple Pod

Code	Description	Power	Llm/W
TOR L75	Torrent, 650mm, 4,875llm, 50°C, Colour 84	42.8W	114
TOR L150	Torrent, 650mm, 9,750llm, 25°C, Colour 84	95.3W	102
TOR L200	Torrent, 1150mm, 13,000llm, 50°C, Colour 84	113.1W	115
TOR L300	Torrent, 1150mm, 19,500llm, 25°C, Colour 84	157.1W	124

Single Pod

Code	Description	Power	Llm/W
TORS L54	Torrent, 1600mm, 4,556llm, 25°C, Colour 84	31.8W	143
TORS L63	Torrent, 1600mm, 5,313llm, 25°C, Colour 84	37.6W	141
TORS L75	Torrent, 1600mm, 6,328llm, 25°C, Colour 84	45.7W	138

Supplied with mounting brackets

DIMMING

Code	Description
A	DALI Digital Addressable Lighting Interface
S	Switch Dimming
D	DSI Digital Dimming

EMERGENCY

Code	Description
LE3	Lithium Standard Emergency 3 Hour
LS3	Lithium Selftest Emergency 3 Hour
LA3	Lithium Autotest Emergency 3 Hour
LSTR	Lithium Reacta-Link Emergency 3 Hour
LA3RC	Lithium Reacta-Control Emergency 3 Hour

All emergency variants are only suitable for ambient temperatures of 25°C.

Triple pod Torrents only available in emergency in 1150mm variants

MISCELLANEOUS

Code	Description
C**	Select Colour Temperature and Rendering; C83, C84, C85, C865, C93, C94
LSF	Low Smoke Zero Halogen

Torrent Triple Installation

220-240V / 50-60Hz
IP65



Terminal Labelling:	
Power	
L1	Switched Live
E	Earth
N	Neutral
Emergency	
L2	Unswitched Live
DA/AT3	DALI Autotest
DA/AT3	DALI Autotest
Dimming	
-D1/DA	Analogue/DSI/DALI
+D2/DA	Analogue/DSI/DALI
L3	Switch Dim / Corridor Function

WARNING: Luminaire must be earthed. Risk of electric shock from LED boards if operated with cover removed. Installation / operation outside of luminaires intended scope invalidates warranty. Suitable only for domestic / light industrial / industrial applications within the scope of EN55015. Tested to compliance with BSEN 60598: specification for general requirements and tests. Must be installed by a suitably qualified person in accordance with all relevant legislation. Ambient operating temperature of 0°C to 25°C. If maximum operating temperature is exceeded luminaire will automatically dim / switch off. Terminal blocks are rated to 16A unless stated otherwise. The light source is non replaceable. **LUMINAIRES WITH EMERGENCY PACK:** When supply is isolated battery output terminals may be live if battery is connected. Isolate mains and battery before servicing. Emergency luminaires require unswitched live connection taken from same phase as switched supply. When unswitched supply is connected status indicator illuminates green, when unswitched supply is disconnected indicator extinguishes and luminaire operates in emergency mode. 24 hour charge period required before undertaking full discharge test. Emergency test sheets provided should be used to record all emergency tests. Batteries should be replaced when 3 hour duration is not met. Excessive switching of permanent live may result in premature battery failure. Battery electrolyte can be harmful to eyes / open wounds, do not puncture, if electrolyte touches skin / eyes flush with water. Do not incinerate batteries.

1.

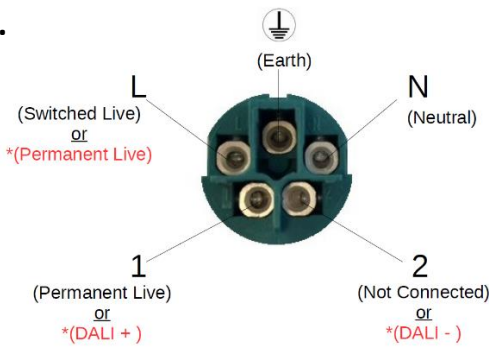

* For E3 DALI fittings, live is permanent and on/off is controlled by DALI

Emergency luminaires are denoted by a green circular label beside the electrical connector. This must be removed after installation in order to prevent contamination in food production environments.

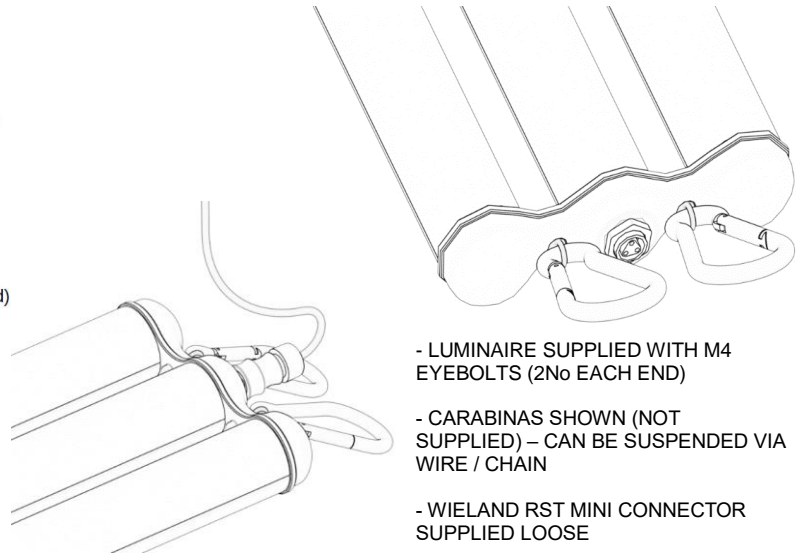

2. Installation instructions

<p>Wire connection</p>	<p>Locking the housing</p>	<p>Opening the housing</p>
------------------------	----------------------------	----------------------------

3. TWISTLOCK – the smart lock

<p>Automatic lock</p>	<p>Optional "SAFE LOCK"</p>	<p>Unlock from "SAFE LOCK"</p>
-----------------------	-----------------------------	--------------------------------

NOTE – THIS LUMINAIRE IS NOT SERVICABLE IN THE FIELD AND MUST BE REPLACED IN THE EVENT OF FAILURE

Torrent Single Installation

220-240V / 50-60Hz
IP65



Terminal Labelling:	
Power	
L1	Switched Live
E	Earth
N	Neutral
Emergency	
L2	Unswitched Live
DA/AT3	DALI Autotest
DA/AT3	DALI Autotest
Dimming	
-/D1/DA	Analogue/DSI/DALI
+/D2/DA	Analogue/DSI/DALI
L3	Switch Dim / Corridor Function

WARNING: Luminaire must be earthed. Risk of electric shock from LED boards if operated with cover removed. Installation / operation outside of luminaires intended scope invalidates warranty. Suitable only for domestic / light industrial / industrial applications within the scope of EN55015. Tested to compliance with BSEN 60598: specification for general requirements and tests. Must be installed by a suitably qualified person in accordance with all relevant legislation. Ambient operating temperature of 0°C to 25°C. If maximum operating temperature is exceeded luminaire will automatically dim / switch off. Terminal blocks are rated to 16A unless stated otherwise. The light source is non replaceable. **LUMINAIRES WITH EMERGENCY PACK:** When supply is isolated battery output terminals may be live if battery is connected. Isolate mains and battery before servicing. Emergency luminaires require unswitched live connection taken from same phase as switched supply. When unswitched supply is connected status indicator illuminates green, when unswitched supply is disconnected indicator extinguishes and luminaire operates in emergency mode. 24 hour charge period required before undertaking full discharge test. Emergency test sheets provided should be used to record all emergency tests. Batteries should be replaced when 3 hour duration is not met. Excessive switching of permanent live may result in premature battery failure. Battery electrolyte can be harmful to eyes / open wounds, do not puncture, if electrolyte touches skin / eyes flush with water. Do not incinerate batteries.

1.

Option 1

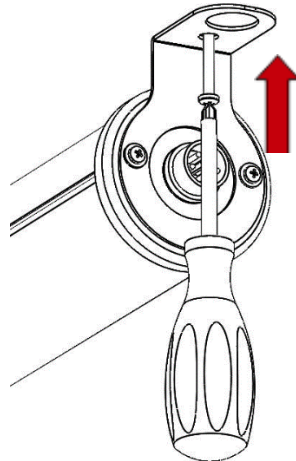

2.

Option 2

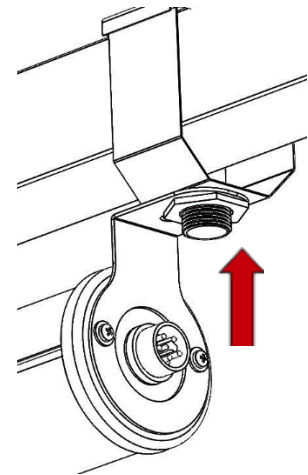

NOTE: DO NOT REMOVE THE STAINLESS BRACKETS AT ANY TIME. REMOVAL WILL VOID THE IP RATING AND WARRANTY.

3.

L- Switched Live
Or
***(Permanent Live)**

1- Permanent Live
Or
***(DALI +)**



N- Neutral

2- Not Connected
Or
***(DALI -)**

*** For E3 DALI fittings, live is permanent and on/off is controlled by DALI**

4.

Installation instructions

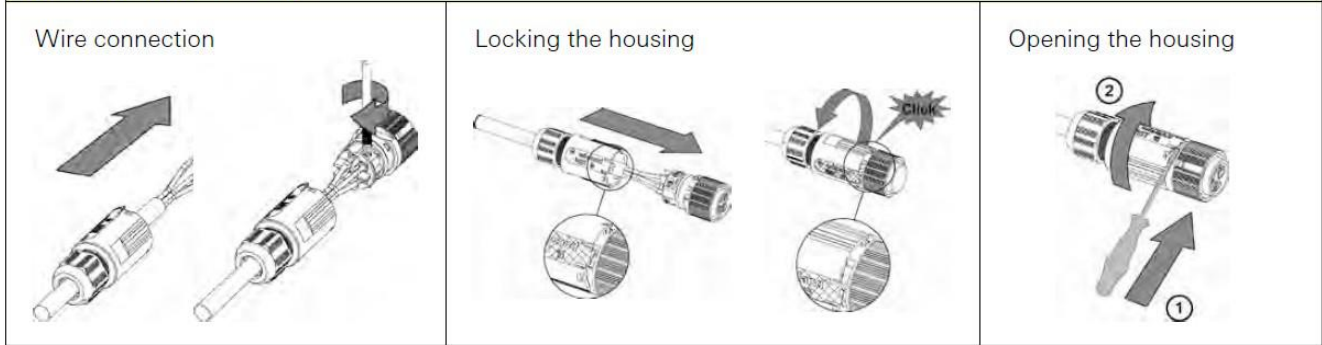

TWISTLOCK – the smart lock



Please note that electrical connections and installations shall only be done by trained experts. Observe the included installation instructions!

Emergency luminaires are denoted by a green circular label beside the electrical connector. This must be removed after installation in order to prevent contamination in food production environments.

5.

6.