



PRODUCT SPECIFICATION

TANEK BULKHEAD



INTRODUCTION

The Tanek Bulkhead incorporates a 1.2mm steel housing with an injection moulded polycarbonate lens to give an IK09 rating ideally suited to external areas where resistance to vandalism or accidental impact is required. The cornice housing and compact design make it ideal for installation above final exit doorways however the Tanek Bulkhead is equally well suited to a range of external applications where a compact robust design is required.

The Tanek Bulkhead is available in a range of lumen outputs, all common dimming variants and emergency options including basic, self test and autotest with lithium batteries for extended lifetime and warranty. We offer a range of wireless control systems providing localised grouping and control as well as comprehensive wireless solutions allowing both standard and emergency luminaires to be centrally monitored. The offer is completed with white or black housing finishes.

UK PA CE IP65 IK09 TM21: L90>60K HOURS / L80>90K HOURS 3 STEP MACADAM ELLIPSE

APPLICATION

- ▶ Exterior
- ▶ Healthcare / Social Housing
- ▶ Industrial / Manufacturing

- › Parking / Exterior
 - › Transport
-

SPECIFICATION

CONSTRUCTION

- › Housing: 1.2mm CR4 steel
- › Finish: Epoxy primer, RAL 9003 leatherette white, salt spray tested
- › Finish: Epoxy primer, RAL 9005 leatherette black, salt spray tested
- › Lens: Injection moulded polycarbonate lens
- › IK09
- › IP65

PERFORMANCE

- › Part L2 compliant
- › 3SCDM Three step Macadams ellipse
- › TM21: L90>60K Hours / L80>90K Hours

ENVIRONMENTAL

- › Designed to allow simple replacement of components with commonly available tools in compliance with the Eco Design Directive, please see the installation leaflet for maintenance instructions.
- › Powered by European branded drivers and emergency modules ensuring replacement parts are easily sourced.
- › Every luminaire is labelled with a unique ID number allowing easy identification of spare parts for the lifetime of the product.
- › Contains no single use plastics or polystyrene packaging.
- › Supplied in plain card boxes with paper tape ensuring packaging is easily recycled.
- › Designed to allow simple disassembly for end of life recycling.
- › UK based manufacturing providing local support throughout the product lifetime and minimising transportation miles.

EMERGENCY

- › Available with optional standard, self test and autotest integral emergency with lithium batteries for extended warranty and lifetime.
- › Optional Reacta-Link wireless emergency for automated centralised reporting.
- › Optional central battery changeover relay

CONTROL

- › Optional compatibility with a range of dimming systems including DALI, DSI and Switch Dimming

INSTALLATION

- Suitable for conduit installation
- Suitable for surface installation

VARIATIONS

- Available with a wide range of colour temperatures and renderings
- Available in a range of housing sizes and lumen outputs
- Available in white or black finishes

IMAGES

PRODUCT IMAGES



Tanek Bulkhead - Black



Tanek Bulkhead - White

TECHNICAL

➤

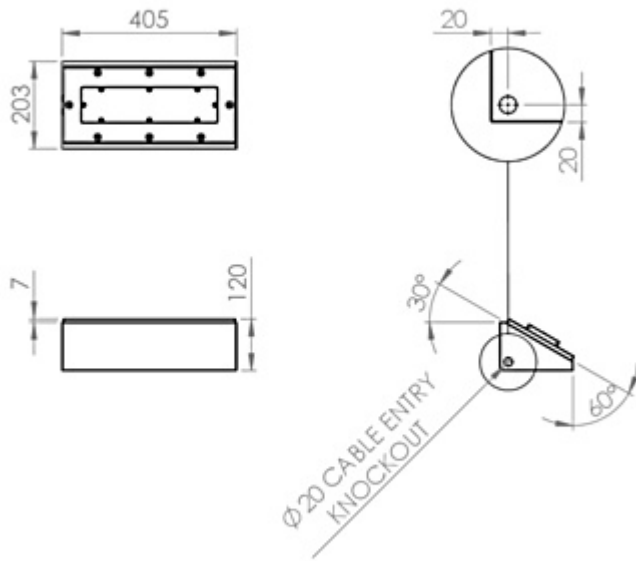

Tanek Bulkhead

WARRANTY

At Dextra our commitment to service has been at the forefront throughout our history spanning more than forty years in the UK lighting market. Our service ethos extends beyond design and delivery, we believe supporting your installation throughout the warranty period is equally crucial, whilst the strength and longevity of Dextra Group provides peace of mind that our warranty will be supported throughout.

The Dextra range is supplied with a five year warranty commencing from the date of delivery. During the first three years defects will be repaired on site and the warranty will include both parts and labour. For the final two years drivers, emergency modules, wireless modules, sensors and LED circuits will be supplied free of charge to replace defective components, labour and other associated costs are not included.

Certain ranges and components are subject to exemptions:

- Lithium batteries are provided with a five year warranty. During the first three years defects will be repaired on site and the warranty will include both parts and labour. For the final two years replacement batteries will be supplied free of charge to replace defective components. Five year warranty became effective as of 03/02/25, Lithium emergency luminaires supplied prior to this date are supported with a three year on site warranty only. Labour and other associated costs are not included. Nickel Metal Hydride and Nickel Cadmium batteries are provided with a one year warranty for parts and labour.

- Emergency luminaires including AME LED, EXI LED, EXI2 LED, EXI Track, HBE LED, HBE2 LED, OAT2 LED, OEZ LED and Twinspot with Nickel Metal Hydride batteries are supplied with a one year warranty for parts and labour. Lithium variants of these ranges are supplied with a three year warranty for parts and labour with the exception of the AME2, EXI3, HBE3 and TWS IP65 L7 ranges which are supplied with a one year parts and labour warranty. TWS IP65 L7 in autotest and wireless variants are supplied with the standard three year lithium battery warranty.
- Protec Micro, PTECF7 Fire Rated Downlights, Serenus and the Opus Sconce are provided with a five year replacement luminaire only warranty. Protec FR Fire Rated Downlights are provided with a 2 year replacement luminaire only warranty.
- Controls systems such as standalone sensors, switches, marshalling boxes and cabling are provided with a one year warranty for both parts and labour. DALI control systems are provided with a two year warranty for both parts and labour.
- LEDextra ranges are supplied with a three year parts or replacement luminaire only warranty with the exception of the IMPR RGBW, the Runway RGBW, the MOD RGBW, Tanek RGBW and the DexRing. These five ranges are supplied with our standard five year warranty during which defects within the first three years will be repaired on site and the warranty includes both parts and labour. For the final two years free of charge replacement components only will be supplied to rectify any failures but labour and other associated costs are not included.
- LEDEX ranges are supplied with a three year replacement luminaire only warranty.
- The Decorative Pendant ranges, Bebo, Dene, Nova, Fino and Stix are supplied with a 3 year replacement luminaire only warranty.

All warranties are subject to correct use of the product and will be invalidated by misuse, for example incorrect installation, unsuitable environmental conditions or incorrect maintenance. It is the duty of the customer to ensure that all the fault lies with the luminaire prior to requesting replacement parts or site repairs. In the event that no defect is found with the product our costs for attending site will be recharged to the customer and credit will not be issued against returned products. No consequential losses incurred resulting from any defect with our product will be reimbursed.

Given the nature of LED technology a small percentage of LEDs may fail during the lifetime of a luminaire, this does not cause a reduction in lumen output. As such LED luminaires are only deemed to be faulty for warranty purposes when in excess of ten percent of LEDs have failed in a single luminaire.

On site repair of products under warranty will be undertaken during normal working hours, 9am to 5pm Monday to Friday, and will require unrestricted access to luminaires. Where required Dextra will provide access equipment to carry out repairs at height, should luminaires have been installed in locations where reasonable provision for maintenance access has not been made we reserve the right to supply replacement product only. On site warranty repairs will only be undertaken on the mainland of the UK and Ireland, in all other locations replacement product only will be provided.

If you require any assistance with regards to our products please contact our Customer Services department on 01747 858100.

ORDER CODES

LUMINAIRE

Code	Description	Power	Llm/W
TK2BH L10 OA	Tanek Bulkhead, 967lm, Open Area	6.9W	140
TK2BH L20 OA	Tanek Bulkhead, 1,934lm, Open Area	12.0W	161
TK2BH L30 OA	Tanek Bulkhead, 2,901lm, Open Area	17.7W	164

EMERGENCY

Code	Description
LE3	Lithium Standard Emergency 3 Hour
LS3	Lithium Selftest Emergency 3 Hour
LA3	Lithium Autotest Emergency 3 Hour
LSTR	Lithium Reacta-Link Emergency 3 Hour
LA3RC	Lithium Reacta-Control Emergency 3 Hour
CB	Central Battery, Please Specify 50V, 110V or 230V when Ordering

MISCELLANEOUS

Code	Description
C**	Select Colour Temperature and Rendering: C83, C84, C85, C865, C93, C94
WH	White Finish
BL	Black Finish
LSF	Low Smoke Zero Halogen

Tanek Bulkhead Installation

220-240V / 50-60Hz

IP** IK**

Terminal Labelling:

Power

L1 Switched Live
E Earth
N Neutral

Emergency

L2 Unswitched Live
DA/AT3 DALI Autotest
DALI Autotest

Dimming

-/D1/DA Analogue/DSI/DALI
+/D2/DA Analogue/DSI/DALI
L3 Switch Dim / Corridor Funct



WARNING: Luminaire must be earthed. Risk of electric shock from LED boards if operated with cover removed. Installation / operation outside of luminaires intended scope invalidates warranty. Suitable only for domestic / light industrial / industrial applications within the scope of EN55015. Tested to compliance with BSEN 60598: specification for general requirements and tests. Must be installed by a suitably qualified person in accordance with all relevant legislation. Ambient operating temperature of 0°C to 25°C. If maximum operating temperature is exceeded luminaire will automatically dim / switch off. Terminal blocks are rated to 16A unless stated otherwise. The light source contained in this luminaire shall only be replaced by the manufacturer or his service agent or a similar qualified person. **LUMINAIRES WITH EMERGENCY PACK:** When supply is isolated battery output terminals may be live if battery is connected. Isolate mains and battery before servicing. Emergency luminaires require unswitched live connection taken from same phase as switched supply. When unswitched supply is connected status indicator illuminates green, when unswitched supply is disconnected indicator extinguishes and luminaire operates in emergency mode. 24 hour charge period required before undertaking full discharge test. Emergency test sheets provided should be used to record all emergency tests. Batteries should be replaced when 3 hour duration is not met. Excessive switching of permanent live may result in premature battery failure. Battery electrolyte can be harmful to eyes / open wounds, do not puncture, if electrolyte touches skin / eyes flush with water. Do not incinerate batteries.

1.

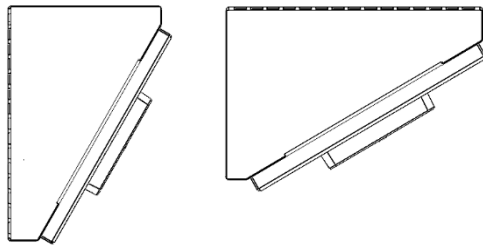

This luminaire can be mounted at either a 60 or 30 degree angle.

2.

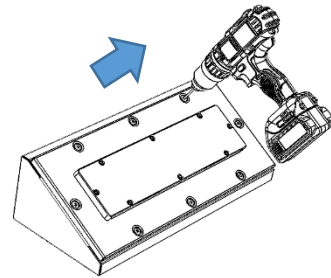

Undo the 8 x M5 6 Lobe Pin Drive screws and remove the frame.

3.

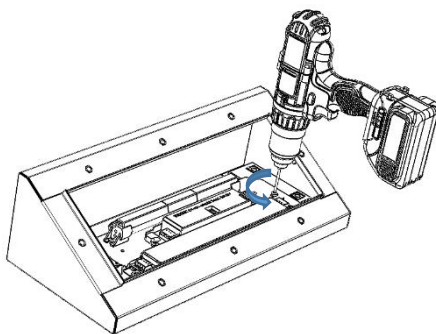

Undo x2 screws and remove the gear tray.

4.

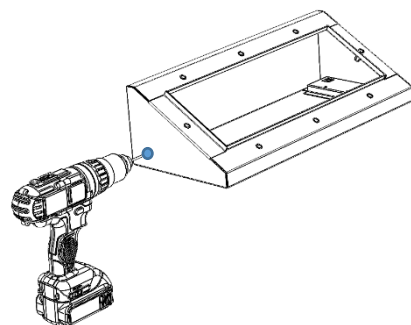

Drill 20mm cable hole in desired location. **(Contractor to supply suitable grommet).**

5.

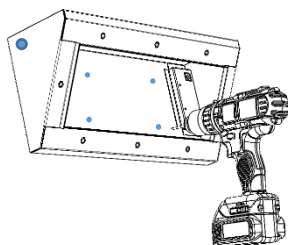

Drill suitable fixings and secure to surface.

Please note, it is the contractor's responsibility to ensure all holes are suitably sealed. Failure to do so will invalidate the luminaire's IP rating.

6.

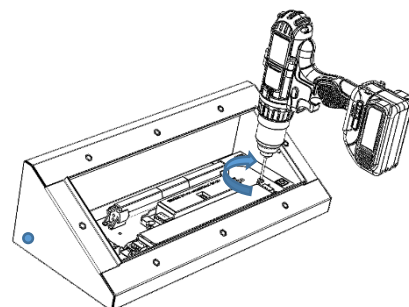

Re secure the gear tray to the body.

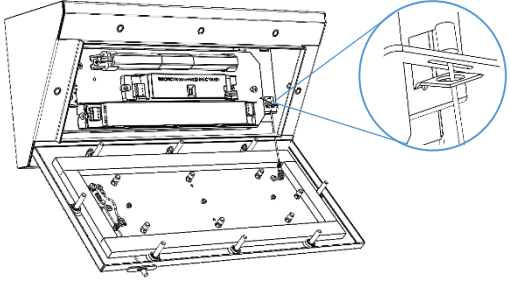
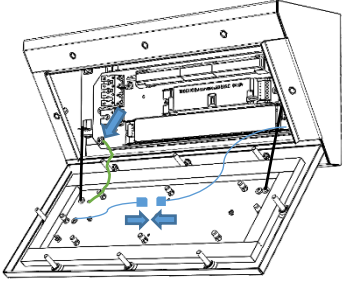
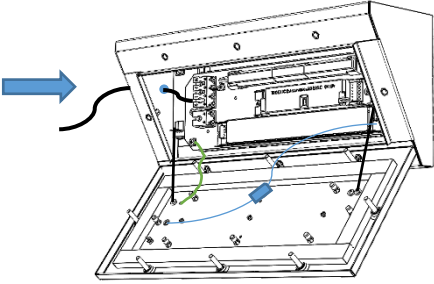
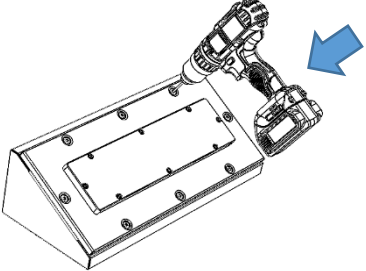
<p>7.</p>  <p>Bend tabs on the body then tether to the front frame.</p>	<p>8.</p>  <p>Connect the frame earth to the gear tray and connect the LED plug ad socket together.</p>
<p>9.</p>  <p>Bring flex through grommet and make relevant connection.</p>	<p>10.</p>  <p>Re secure the front frame to the body.</p>
<p>11.</p>	<p>12.</p>
<p>13.</p>	<p>14.</p>