



# PRODUCT SPECIFICATION

---

STIX



---

## INTRODUCTION

---

Our decorative pendants consist of five unique ranges each designed to align with specific architectural themes. The cylindrical Nova and the spherical Fino offer a modern and minimalist appearance, the Dene and Bebo have a traditional domed and coppered reflector with industrial themes while the Stix can be grouped into clusters to create dramatic architectural features.

The Nova, Dene and Bebo are offered with either black or white housings, the Dene and Bebo include coppered internal reflectors whilst the Nova utilises a lensed optic with black collar. All five ranges are supplied complete with ceiling roses and integrated drivers, and are also available with optional Global track adaptors where needed for installation with three circuit track systems. All five variants in our decorative pendant range are supplied with CRI90 LEDs as standard for excellent colour rendering in retail and hospitality applications and can be supplied in either 3000 Kelvin for warm and inviting spaces or 4000 Kelvin for a bright, white clean atmosphere. This breadth of offer ensures that our decorative pendant range can be used in hotels, bars and restaurants, receptions and office break out spaces to create inviting and contemporary spaces with visual interest and atmosphere for customers and employees alike.



CE IP20 TM21: L90>60K HOURS / L80>90K HOURS 3 STEP MACADAM ELLIPSE

---

## APPLICATION

---

- › Canteen
  - › Commercial / Offices
  - › Education
  - › Hotel / Leisure
  - › Retail
- 

## SPECIFICATION

---

### PERFORMANCE

- › 3SCDM Three step Macadams ellipse
- › TM21: L90>60K Hours / L80>90K Hours

### ENVIRONMENTAL

- › Designed to allow simple replacement of components with commonly available tools in compliance with the Eco Design Directive, please see the installation leaflet for maintenance instructions.
- › Powered by European branded drivers and emergency modules ensuring replacement parts are easily sourced.
- › Every luminaire is labelled with a unique ID number allowing easy identification of spare parts for the lifetime of the product.
- › Supplied in plain card boxes with paper tape ensuring packaging is easily recycled.
- › Designed to allow simple disassembly for end of life recycling.

### INSTALLATION

- › Supplied with ceiling rose for solid ceiling installation
- › Available with optional Global track adaptor for 3 circuit track installation

### VARIATIONS

- › Available with a wide range of colour temperatures and renderings

### CONSTRUCTION

- › Housing: Polycarbonate with matt black suspension point
-

---

IMAGES

---

PRODUCT IMAGES



Stix



Stix array



Stix array

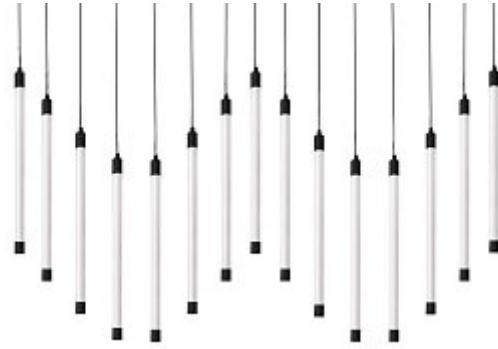

Stix array



Stix install example



Stix install example

TECHNICAL

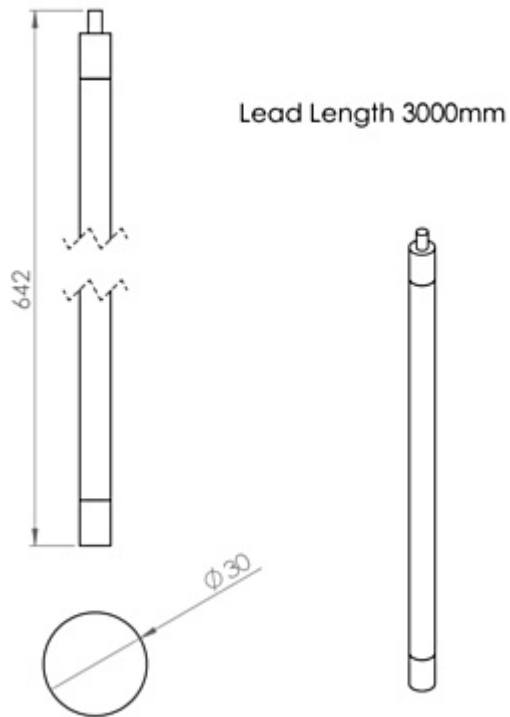

Stix



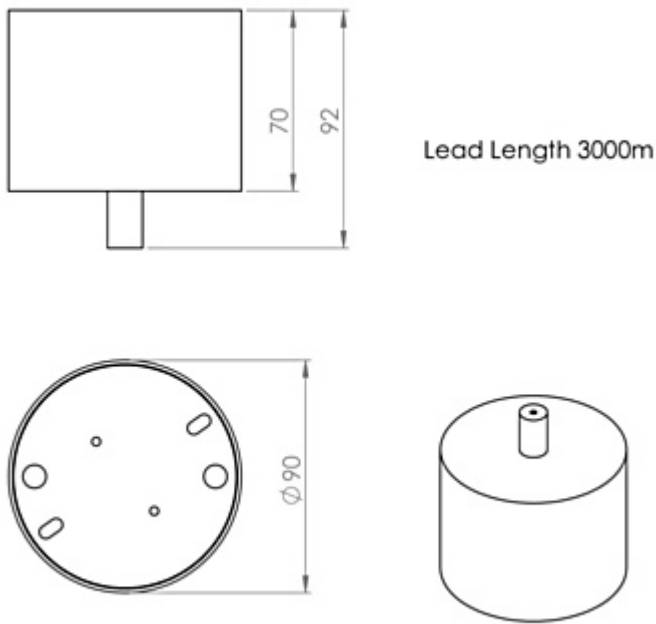

#### Ceiling Rose

## WARRANTY

At Dextra our commitment to service has been at the forefront throughout our history spanning more than forty years in the UK lighting market. Our service ethos extends beyond design and delivery, we believe supporting your installation throughout the warranty period is equally crucial, whilst the strength and longevity of Dextra Group provides peace of mind that our warranty will be supported throughout.

The Dextra range is supplied with a five year warranty commencing from the date of delivery. During the first three years defects will be repaired on site and the warranty will include both parts and labour. For the final two years drivers, emergency modules, wireless modules, sensors and LED circuits will be supplied free of charge to replace defective components, labour and other associated costs are not included.

Certain ranges and components are subject to exemptions:

- Lithium batteries are provided with a five year warranty. During the first three years defects will be repaired on site and the warranty will include both parts and labour. For the final two years replacement batteries will be supplied free of charge to replace defective components. Five year warranty became effective as of 03/02/25, Lithium emergency luminaires supplied prior to this date are supported with a three year on site warranty only. Labour and other associated costs are not included. Nickel Metal Hydride and Nickel Cadmium batteries are provided with a one year warranty for parts and labour.

- Emergency luminaires including AME LED, EXI LED, EXI2 LED, EXI Track, HBE LED, HBE2 LED, OAT2 LED, OEZ LED and Twinspot with Nickel Metal Hydride batteries are supplied with a one year warranty for parts and labour. Lithium variants of these ranges are supplied with a three year warranty for parts and labour with the exception of the AME2, EXI3, HBE3 and TWS IP65 L7 ranges which are supplied with a one year parts and labour warranty. TWS IP65 L7 in autotest and wireless variants are supplied with the standard three year lithium battery warranty.
- Protec Micro, PTECF7 Fire Rated Downlights, Serenus and the Opus Sconce are provided with a five year replacement luminaire only warranty. Protec FR Fire Rated Downlights are provided with a 2 year replacement luminaire only warranty.
- Controls systems such as standalone sensors, switches, marshalling boxes and cabling are provided with a one year warranty for both parts and labour. DALI control systems are provided with a two year warranty for both parts and labour.
- LEDextra ranges are supplied with a three year parts or replacement luminaire only warranty with the exception of the IMPR RGBW, the Runway RGBW, the MOD RGBW, Tanek RGBW and the DexRing. These five ranges are supplied with our standard five year warranty during which defects within the first three years will be repaired on site and the warranty includes both parts and labour. For the final two years free of charge replacement components only will be supplied to rectify any failures but labour and other associated costs are not included.
- LEDEX ranges are supplied with a three year replacement luminaire only warranty.
- The Decorative Pendant ranges, Bebo, Dene, Nova, Fino and Stix are supplied with a 3 year replacement luminaire only warranty.

All warranties are subject to correct use of the product and will be invalidated by misuse, for example incorrect installation, unsuitable environmental conditions or incorrect maintenance. It is the duty of the customer to ensure that all the fault lies with the luminaire prior to requesting replacement parts or site repairs. In the event that no defect is found with the product our costs for attending site will be recharged to the customer and credit will not be issued against returned products. No consequential losses incurred resulting from any defect with our product will be reimbursed.

Given the nature of LED technology a small percentage of LEDs may fail during the lifetime of a luminaire, this does not cause a reduction in lumen output. As such LED luminaires are only deemed to be faulty for warranty purposes when in excess of ten percent of LEDs have failed in a single luminaire.

On site repair of products under warranty will be undertaken during normal working hours, 9am to 5pm Monday to Friday, and will require unrestricted access to luminaires. Where required Dextra will provide access equipment to carry out repairs at height, should luminaires have been installed in locations where reasonable provision for maintenance access has not been made we reserve the right to supply replacement product only. On site warranty repairs will only be undertaken on the mainland of the UK and Ireland, in all other locations replacement product only will be provided.

**If you require any assistance with regards to our products please contact our Customer Services department on 01747 858100.**

---

---

## ORDER CODES

---

### LUMINAIRE

Code	Description	Power	Llm/W
STX L07 BL C93	Stix, 792llm, Black, Colour 93	9.2W	86
STX L07 BL C94	Stix, 792llm, Black, Colour 94	9.2W	86

---

### MISCELLANEOUS

Code	Description
GB	Global Adaptor Fixed output
A GB	Global Adaptor DALI

---



220-240V / 50-60Hz  
IP20 IK00

**Terminal Labelling:**  
**Power**  
L1 Switched Live  
E Earth  
N Neutral

**WARNING:** Luminaire must be earthed. Risk of electric shock from LED boards if operated with cover removed. Installation / operation outside of luminaires intended scope invalidates warranty. Suitable only for domestic / light industrial / industrial applications within the scope of EN55015. Tested to compliance with BSEN 60598: specification for general requirements and tests. Must be installed by a suitably qualified person in accordance with all relevant legislation. Ambient operating temperature of 0°C to 25°C. If maximum operating temperature is exceeded luminaire will automatically dim / switch off. Terminal blocks are rated to 16A unless stated otherwise. The light source contained in this luminaire shall only be replaced by the manufacturer or his service agent or a similar qualified person. **LUMINAIRES WITH EMERGENCY PACK:** When supply is isolated battery output terminals may be live if battery is connected. Isolate mains and battery before servicing. Emergency luminaires require unswitched live connection taken from same phase as switched supply. When unswitched supply is connected status indicator illuminates green, when unswitched supply is disconnected indicator extinguishes and luminaire operates in emergency mode. 24 hour charge period required before undertaking full discharge test. Emergency test sheets provided should be used to record all emergency tests. Batteries should be replaced when 3 hour duration is not met. Excessive switching of permanent live may result in premature battery failure. Battery electrolyte can be harmful to eyes / open wounds, do not puncture, if electrolyte touches skin / eyes flush with water. Do not incinerate batteries.

**Installation guide applies to:**

**Dene**  
**Bebo**  
**Stix**  
**Nova**  
**Fino**

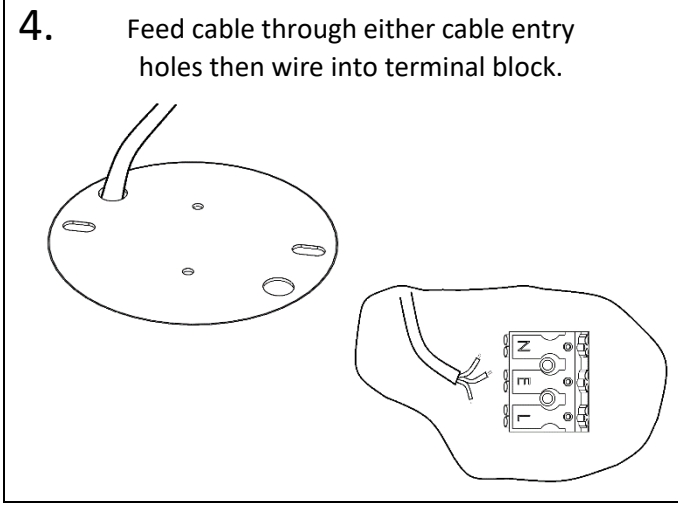
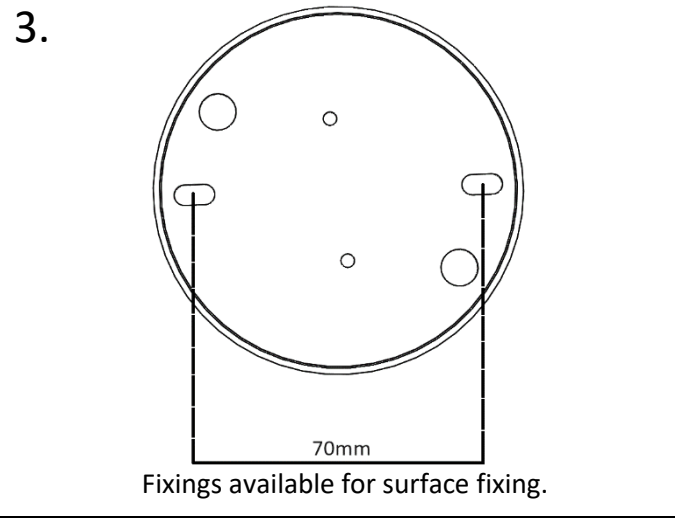
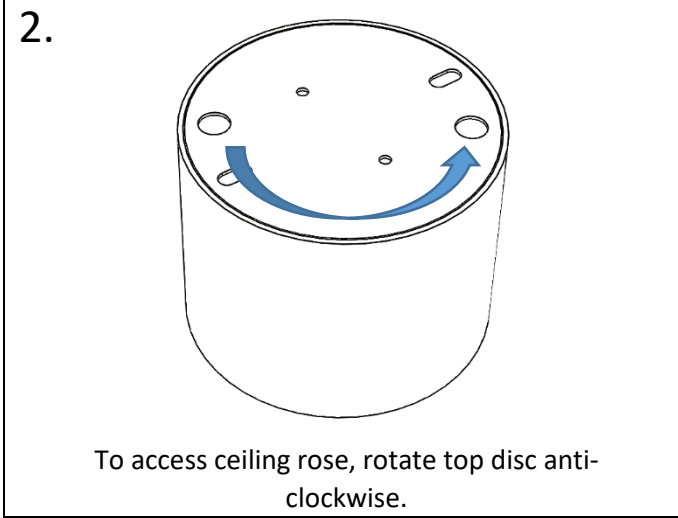
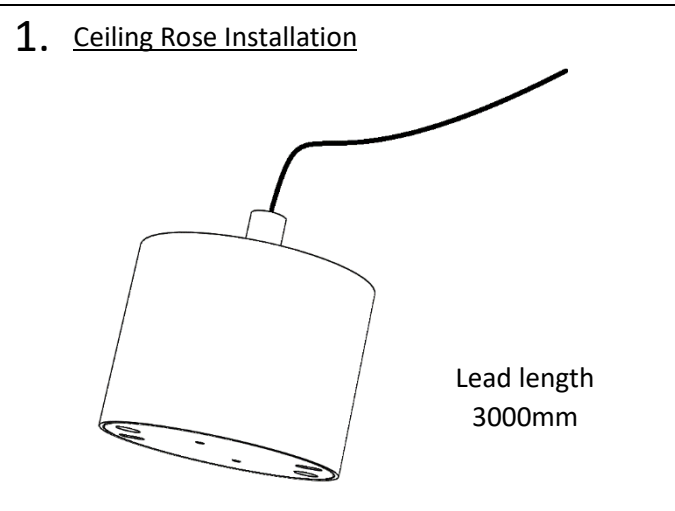

**5.**

Once wired, repeat step 2 in reverse.

## Decorative Pendant Installation

### 6. Track Adaptor Installation

LEFT HAND CONNECTIONS SHOWN, REVERSE  
FOR RIGHT HAND CONNECTION

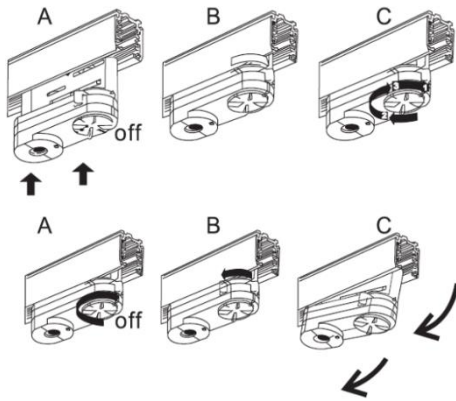

1. Ensure the selector dial is turned to the off position.
2. Set the locking lever to the side.
3. Engage the adaptor into the track with the guide lug.
4. Turn the lever towards the front until it locks correctly with the track system.
5. Select the circuit by turning the selector dial to 1, 2 or 3.
6. Remove the adaptor by reversing the above process.

### 7. Maintenance

Disconnect luminaire before undertaking maintenance or cleaning.

Cleaning should be undertaken on external parts of the luminaire only using a slightly damp lint free cloth.

This is a non-user serviceable part please contact Dextra for assistance.

8.

9.

10.

11.

12.