



PRODUCT SPECIFICATION

SKY-LIGHT 2



INTRODUCTION

The Sky-Light 2 offers a highly efficient lens controlled solution for a wide range of applications from retail through to light industry, manufacturing and logistics. The lensed optic provides excellent efficiency and precise control ensuring light is cast exactly where required. The minimalist steel housing ensures that the Sky-Light 2 is unobtrusive whilst allowing cool operation of LEDs maximising life time.

With a 90° beam angle as standard the Sky-Light 2 is optimised for retail applications ensuring gondolas and merchandise are lit to optimal effect creating an attractive environment for customers whilst minimising glare. Other lens options can be offered ensuring the Sky-Light 2 can be tailored to a multitude of applications. The Sky-Light 2 can also be offered with all common dimming and lithium emergency variants. We offer a range of wireless control systems providing localised grouping and control as well as comprehensive wireless solutions allowing both standard and emergency luminaires to be centrally monitored..



CE IP20 TM21: L90>60K HOURS / L80>90K HOURS 3 STEP MACADAM ELLIPSE

APPLICATION

- ▶ Hotel / Leisure
- ▶ Industrial / Manufacturing

- › Retail
 - › Transport
 - › Warehouse / Storage
-

SPECIFICATION

CONSTRUCTION

- › Housing: 0.7mm CR4 steel
- › Finish: Polyester powder painted BS 00E55 matt white 60% gloss
- › Lens: Injection moulded polycarbonate lens
- › IP20

PERFORMANCE

- › Part L2 compliant
- › 3SCDM Three step Macadams ellipse
- › TM21: L90>60K Hours / L80>90K Hours
- › Up to 184 luminaire lumens per circuit Watt.

ENVIRONMENTAL

- › Designed to allow simple replacement of components with commonly available tools in compliance with the Eco Design Directive, please see the installation leaflet for maintenance instructions.
- › Powered by European branded drivers and emergency modules ensuring replacement parts are easily sourced.
- › Every luminaire is labelled with a unique ID number allowing easy identification of spare parts for the lifetime of the product.
- › Contains no single use plastics or polystyrene packaging.
- › Supplied in plain card boxes with paper tape ensuring packaging is easily recycled.
- › Designed to allow simple disassembly for end of life recycling.
- › UK based manufacturing providing local support throughout the product lifetime and minimising transportation miles.

EMERGENCY

- › Available with optional standard, self test and autotest integral emergency with lithium batteries for extended warranty and lifetime.
- › Optional Reacta-Link wireless emergency for automated centralised reporting.
- › Optional Reacta-Control wireless emergency for automated centralised reporting.
- › Optional central battery changeover relay

CONTROL

- Optional compatibility with a range of dimming systems including DALI, DSI and Switch Dimming
- Optional integral Reacta-Link for integration with Reacta-Link wireless installations

INSTALLATION

- Suitable for suspended installation

VARIATIONS

- Available with a wide range of colour temperatures and renderings
- Available in a range of housing sizes and lumen outputs

IMAGES

PRODUCT IMAGES

Sky-Light 2 3 Lens 500mm



Sky-Light 2 4 Lens 1000mm



Sky-Light 2 6 Lens 1000mm



Sky-Light 2 6 Lens 1500mm



Sky-Light 2 9 Lens 1500mm

TECHNICAL

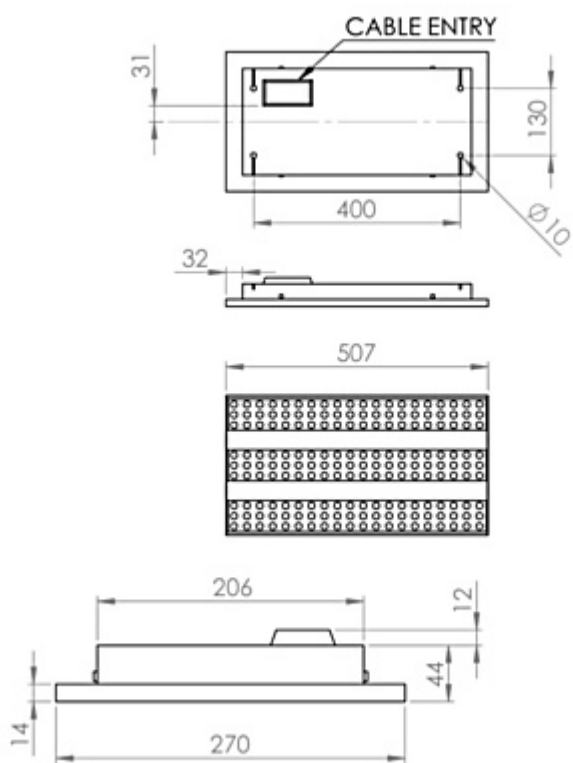

Sky-Light 2 3 Circuit 500mm



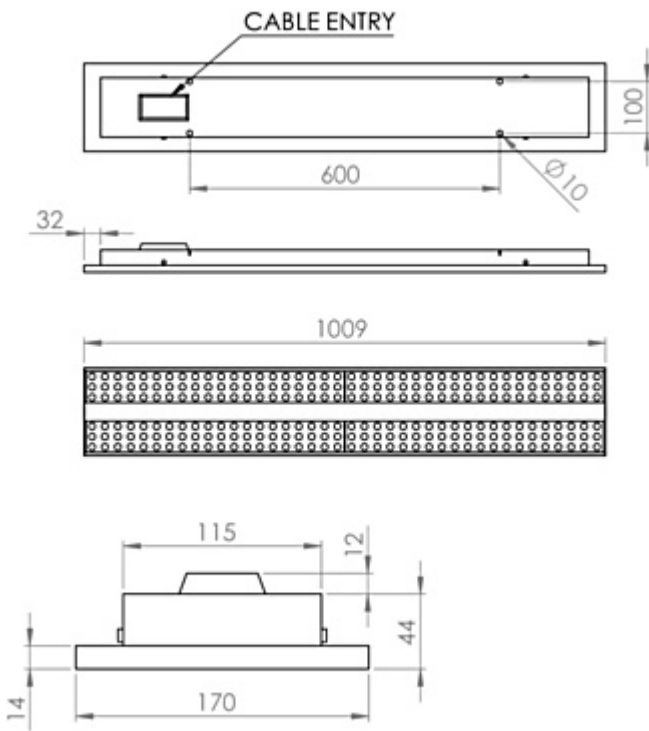

Sky-Light 2 4 Circuit 1000mm

>

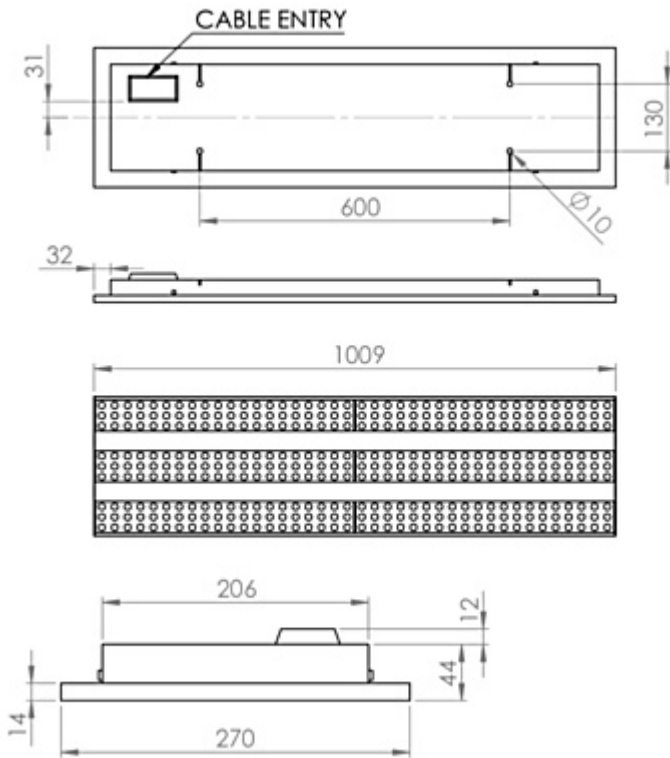

Sky-Light 2 6 Circuit 1000mm

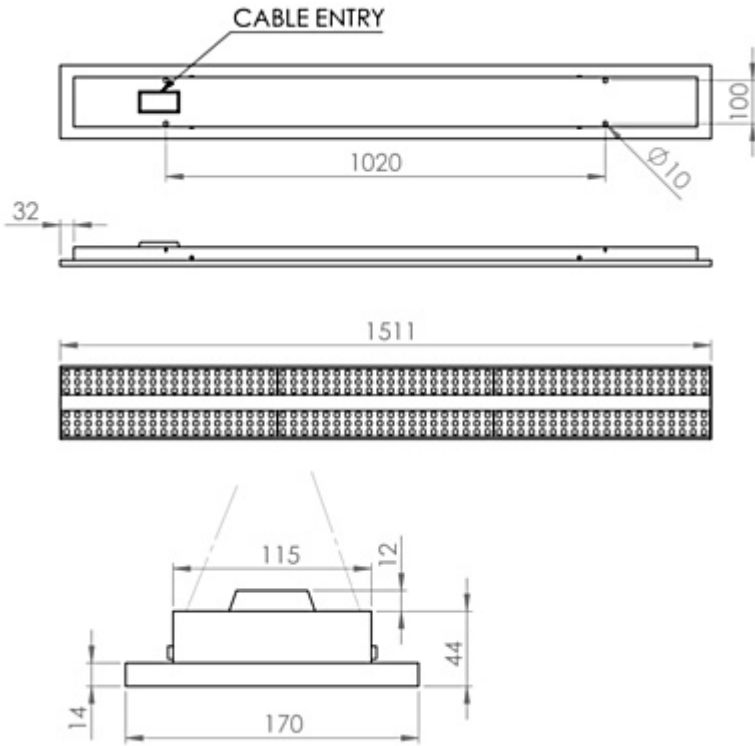

Sky-Light 2 6 Circuit 1500mm

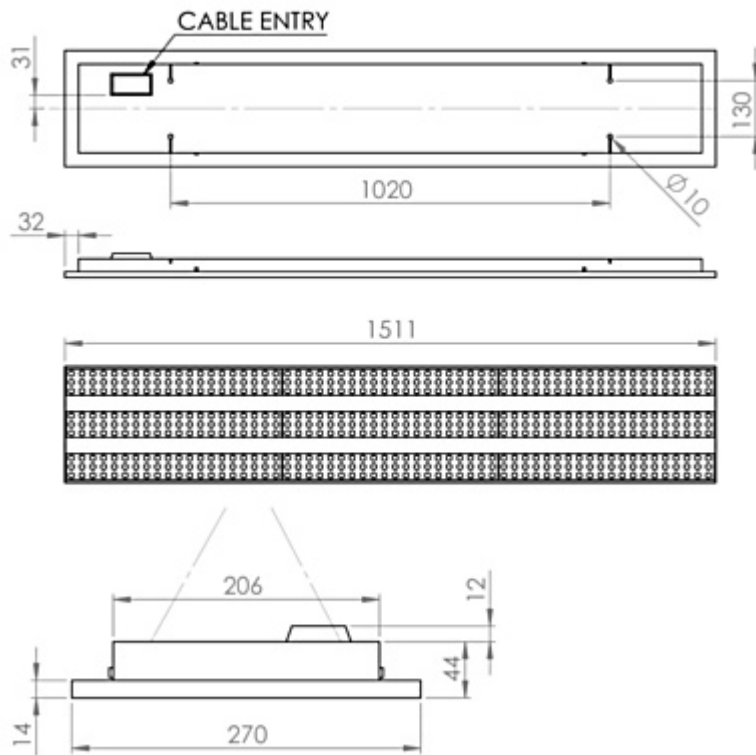

Sky-Light 2 9 Circuit 1500mm

WARRANTY

At Dextra our commitment to service has been at the forefront throughout our history spanning more than forty years in the UK lighting market. Our service ethos extends beyond design and delivery, we believe supporting your installation throughout the warranty period is equally crucial, whilst the strength and longevity of Dextra Group provides peace of mind that our warranty will be supported throughout.

The Dextra range is supplied with a five year warranty commencing from the date of delivery. During the first three years defects will be repaired on site and the warranty will include both parts and labour. For the final two years drivers, emergency modules, wireless modules, sensors and LED circuits will be supplied free of charge to replace defective components, labour and other associated costs are not included.

Certain ranges and components are subject to exemptions:

- Lithium batteries are provided with a five year warranty. During the first three years defects will be repaired on site and the warranty will include both parts and labour. For the final two years replacement batteries will be supplied free of charge to replace defective components. Five year warranty became effective as of 03/02/25, Lithium emergency luminaires supplied prior to this date are supported with a three year on site warranty only. Labour and other associated costs are not included. Nickel Metal Hydride and Nickel Cadmium batteries are provided with a one year warranty for parts and labour.
- Emergency luminaires including AME LED, EXI LED, EXI2 LED, EXI Track, HBE LED, HBE2 LED, OAT2 LED, OEZ LED and Twinspot with Nickel Metal Hydride batteries are supplied with a one year warranty for parts and labour. Lithium variants of these ranges are supplied with a three year warranty for parts and labour with the exception of the AME2, EXI3, HBE3 and TWS IP65 L7 ranges which are supplied with a one year parts and labour warranty. TWS IP65 L7 in autotest and wireless variants are supplied with the standard three year lithium battery warranty.
- Protec Micro, PTECF7 Fire Rated Downlights, Serenus and the Opus Sconce are provided with a five year replacement luminaire only warranty. Protec FR Fire Rated Downlights are provided with a 2 year replacement luminaire only warranty.
- Controls systems such as standalone sensors, switches, marshalling boxes and cabling are provided with a one year warranty for both parts and labour. DALI control systems are provided with a two year warranty for both parts and labour.
- LEDextra ranges are supplied with a three year parts or replacement luminaire only warranty with the exception of the IMPR RGBW, the Runway RBGW, the MOD RGBW, Tanek RGBW and the DexRing. These five ranges are supplied with our standard five year warranty during which defects within the first three years will be repaired on site and the warranty includes both parts and labour. For the final two years free of charge replacement components only will be supplied to rectify any failures but labour and other associated costs are not included.
- LEDEX ranges are supplied with a three year replacement luminaire only warranty.

- The Decorative Pendant ranges, Bebo, Dene, Nova, Fino and Stix are supplied with a 3 year replacement luminaire only warranty.

All warranties are subject to correct use of the product and will be invalidated by misuse, for example incorrect installation, unsuitable environmental conditions or incorrect maintenance. It is the duty of the customer to ensure that all the fault lies with the luminaire prior to requesting replacement parts or site repairs. In the event that no defect is found with the product our costs for attending site will be recharged to the customer and credit will not be issued against returned products. No consequential losses incurred resulting from any defect with our product will be reimbursed.

Given the nature of LED technology a small percentage of LEDs may fail during the lifetime of a luminaire, this does not cause a reduction in lumen output. As such LED luminaires are only deemed to be faulty for warranty purposes when in excess of ten percent of LEDs have failed in a single luminaire.

On site repair of products under warranty will be undertaken during normal working hours, 9am to 5pm Monday to Friday, and will require unrestricted access to luminaires. Where required Dextra will provide access equipment to carry out repairs at height, should luminaires have been installed in locations where reasonable provision for maintenance access has not been made we reserve the right to supply replacement product only. On site warranty repairs will only be undertaken on the mainland of the UK and Ireland, in all other locations replacement product only will be provided.

If you require any assistance with regards to our products please contact our Customer Services department on 01747 858100.

ORDER CODES

LUMINAIRE

Code	Description	Power	Llm/W
SKY2 053 L80 **	Sky-Light 2, 500mm, 3 Card, 8,247lm, Colour 84	44.6W	184
SKY2 053 L100 **	Sky-Light 2, 500mm, 3 Card, 9,700lm, Colour 84	58.5W	165
SKY2 053 L160 **	Sky-Light 2, 500mm, 3 Card, 15,520lm, Colour 84	93.9W	165
SKY2 104 L100 **	Sky-Light 2, 1000mm, 4 Card, 9,700lm, Colour 84	53.1W	182
SKY2 104 L160 **	Sky-Light 2, 1000mm, 4 Card, 15,520lm, Colour 84	94.3W	164
SKY2 104 L200 **	Sky-Light 2, 1000mm, 4 Card, 19,400lm, Colour 84	120.4W	161
SKY2 106 L120 **	Sky-Light 2, 1000mm, 6 Card, 11,640lm, Colour 84	64.1W	181
SKY2 106 L160 **	Sky-Light 2, 1000mm, 6 Card, 15,520lm, Colour 84	89.1W	174
SKY2 106 L200 **	Sky-Light 2, 1000mm, 6 Card, 19,400lm, Colour 84	112.9W	171
SKY2 106 L240 **	Sky-Light 2, 1000mm, 6 Card, 23,280lm, Colour 84	137.0W	169
SKY2 106 L320 **	Sky-Light 2, 1000mm, 6 Card, 31,040lm, Colour 84	196.1W	158
SKY2 156 L120 **	Sky-Light 2, 1500mm, 6 Card, 11,640lm, Colour 84	64.1W	181
SKY2 156 L160 **	Sky-Light 2, 1500mm, 6 Card, 15,520lm, Colour 84	89.1W	174
SKY2 156 L200 **	Sky-Light 2, 1500mm, 6 Card, 19,400lm, Colour 84	112.9W	171
SKY2 156 L240 **	Sky-Light 2, 1500mm, 6 Card, 23,280lm, Colour 84	137.0W	169
SKY2 156 L320 **	Sky-Light 2, 1500mm, 6 Card, 31,040lm, Colour 84	196.1W	158
SKY2 159 L400 **	Sky-Light 2, 1500mm, 9 Card, 38,800lm, Colour 84	243.3W	159
SKY2 159 L480 **	Sky-Light 2, 1500mm, 9 Card, 46,560lm, Colour 84	282.6W	164

Llm figures are based on OA Optic.

**Please add Optic suffix required

OPTIC

Code	Description
UW	Ultra Wide 110°
OA	Open Area
HR	High Rack

DIMMING

Code	Description
A	DALI Digital Addressable Lighting Interface
S	Switch Dimming
D	DSI Digital Dimming
H	HFR Analogue 1-10v
C	Bi-Level Dimming For Standalone Switched Sensor

CONTROL

Code	Description
RLI	Reacta-Link, Wireless Enabled Luminaire

Please click [here](#) for full details on our wireless controls.

EMERGENCY

Code	Description
LE3	Lithium Standard Emergency 3 Hour
LS3	Lithium Selftest Emergency 3 Hour
LA3	Lithium Autotest Emergency 3 Hour
LSTR	Lithium Reacta-Link Emergency 3 Hour
LA3RC	Lithium Reacta-Control Emergency 3 Hour
CB	Central Battery, Please Specify 50V, 110V or 230V when Ordering

MISCELLANEOUS

Code	Description
C**	Select Colour Temperature and Rendering: C83, C84, C85, C865, C93, C94
LSF	Low Smoke Zero Halogen

SUSP SKY 5M BF X2	5M Suspension Kit Barrel Fix
SUSP SKY 5M LO X2	5M Loop Over Suspension Kit (Two Drops)
SUSP SKY 10M LO X2	10M Loop Over Suspension Kit (Two Drops)

220-240V / 50-60Hz
IP20 IK03



WARNING: Luminaire must be earthed. Risk of electric shock from LED boards if operated with cover removed. Installation / operation outside of luminaires intended scope invalidates warranty. Suitable only for domestic / light industrial / industrial applications within the scope of EN55015. Tested to compliance with BSEN 60598: specification for general requirements and tests. Must be installed by a suitably qualified person in accordance with all relevant legislation. Ambient operating temperature of 0°C to 25°C. If maximum operating temperature is exceeded luminaire will automatically dim / switch off. Terminal blocks are rated to 16A unless stated otherwise. The light source contained in this luminaire shall only be replaced by the manufacturer or his service agent or a similar qualified person. **LUMINAIRES WITH EMERGENCY PACK:** When supply is isolated battery output terminals may be live if battery is connected. Isolate mains and battery before servicing. Emergency luminaires require unswitched live connection taken from same phase as switched supply. When unswitched supply is connected status indicator illuminates green, when unswitched supply is disconnected indicator extinguishes and luminaire operates in emergency mode. 24 hour charge period required before undertaking full discharge test. Emergency test sheets provided should be used to record all emergency tests. Batteries should be replaced when 3 hour duration is not met. Excessive switching of permanent live may result in premature battery failure. Battery electrolyte can be harmful to eyes / open wounds, do not puncture, if electrolyte touches skin / eyes flush with water. Do not incinerate batteries.

Terminal Labelling:

Power

- L1 Switched Live
- E Earth
- N Neutral

Emergency

- L2 Unswitched Live
- DA/AT3 DALI Autotest
- DALI Autotest

Dimming

- /D1/DA Analogue/DSI/DALI
- +/D2/DA Analogue/DSI/DALI
- L3 Switch Dim / Corridor Function

1

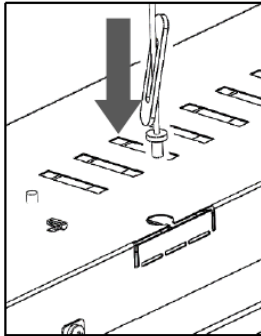

Insert toggle to suspend

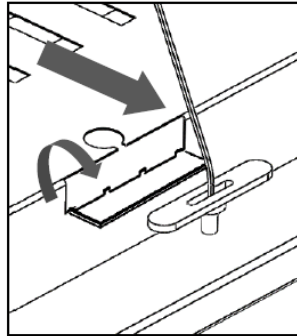

Bend the tab to release

2

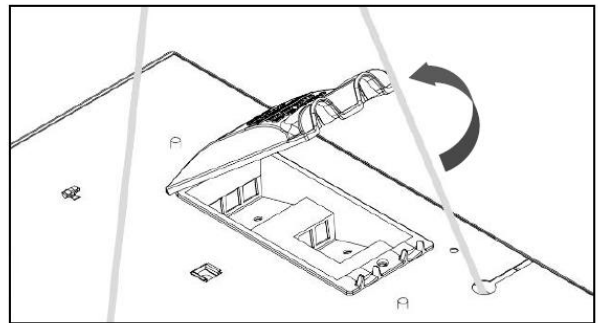

Unscrew and open the back flap to gain access to the terminal blocks.

3

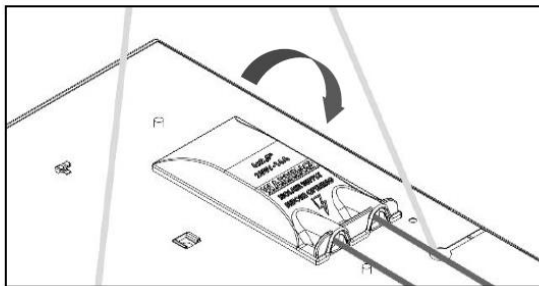

Connect the wires to the terminal blocks, then close and refasten the back-flap to secure them.

4

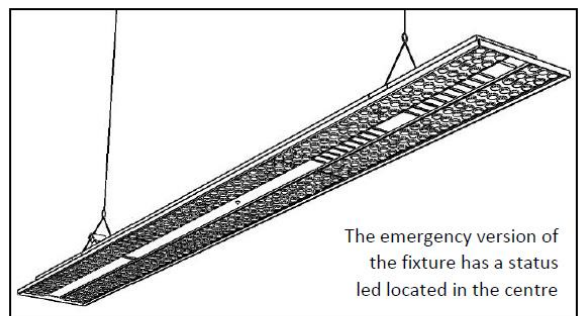

Check that the fitting is level before powering it on for operation.

Maintenance:

1. Disconnect the luminaire before undertaking any maintenance or cleaning.
2. Clean only the external parts of the luminaire with a slightly damp, lint-free cloth.
3. Using a pan pozi screwdriver, you can detach the led circuit from underneath the tray, allowing access to the fitting and removal of the components.
4. If you require spare components, please contact us for assistance.

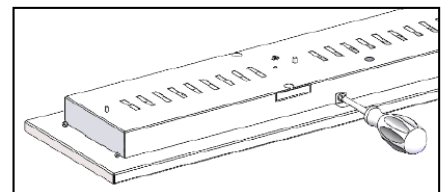

Led Circuit

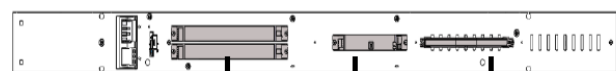
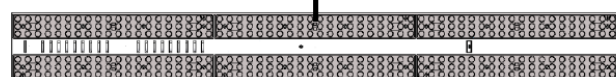

Driver

Module

Battery