



PRODUCT SPECIFICATION

SIRA SUSPENDED CONTINUOUS



INTRODUCTION

The Sira Suspended Continuous is suitable for suspended installation in continuous run formats with bi directional output, 40% up, 60% down or downlight only. This versatility is combined with a shallow body profile and lensed optic providing a sleek appearance and compliance with the glare regulations of BSEN 12464 for use in offices and schools whilst maintaining excellent efficiency.

The versatility of the Sira is further enhanced with a wide range of lumen packages, optional integral sensors, wireless controls and all common dimming and lithium emergency variants. For simplicity of installation the Sira Suspended Continuous is supplied complete with through wire cabling.

We offer a range of wireless control systems providing localised grouping and control as well as comprehensive wireless solutions allowing both standard and emergency luminaires to be centrally monitored.



CE IP20 TM21: L90>60K HOURS / L80>90K HOURS 3 STEP MACADAM ELLIPSE

APPLICATION

- ▶ Commercial / Offices
- ▶ Education
- ▶ Office

SPECIFICATION

CONSTRUCTION

- › Housing: 0.7mm CR4 steel
- › Finish: Polyester powder painted BS 00E55 matt white 60% gloss
- › Finish: Polyester powder painted RAL 9006 matt grey
- › Finish: Polyester powder painted RAL 9005 matt black
- › Lens: Injection moulded polycarbonate lens
- › IP20

PERFORMANCE

- › Part L2 compliant
- › BSEN 12464-1:2011 3000 Candela 65° and UGR 19 compliance
- › 3SCDM Three step Macadams ellipse
- › TM21: L90>60K Hours / L80>90K Hours
- › Bi-Directional 40% up 60% down
- › Up to 154 luminaire lumens per circuit Watt.

ENVIRONMENTAL

- › Designed to allow simple replacement of components with commonly available tools in compliance with the Eco Design Directive, please see the installation leaflet for maintenance instructions.
- › Powered by European branded drivers and emergency modules ensuring replacement parts are easily sourced.
- › Every luminaire is labelled with a unique ID number allowing easy identification of spare parts for the lifetime of the product.
- › Contains no single use plastics or polystyrene packaging.
- › Supplied in plain card boxes with paper tape ensuring packaging is easily recycled.
- › Designed to allow simple disassembly for end of life recycling.
- › UK based manufacturing providing local support throughout the product lifetime and minimising transportation miles.

EMERGENCY

- › Available with optional standard, self test and autotest integral emergency with lithium batteries for extended warranty and lifetime.
- › Optional Reacta-Link wireless emergency for automated centralised reporting.
- › Optional Reacta-Control wireless emergency for automated centralised reporting.
- › Optional central battery changeover relay

CONTROL

- Optional compatibility with a range of dimming systems including DALI, DSI and Switch Dimming
- Optional Integral R44 presence and daylight sensor
- Optional Integral Reacta-Air wireless presence and daylight regulations sensor
- Optional integral Reacta-Link for integration with Reacta-Link wireless installations
- Optional integral Reacta-Control for integration with Reacta-Control wireless installations

INSTALLATION

- Suitable for suspended installation
- Suitable for two point suspension
- Available with adjustable corners
- Through Wire variants are supplied with 6 pole 1.5mm loom
- Please note bi-directional variants use two drivers.

VARIATIONS

- Available with a wide range of colour temperatures and renderings
- Available in a range of housing sizes and lumen outputs
- Available in white or black finishes

IMAGES

PRODUCT IMAGES



Sira Suspended Continuous



Corner Piece

TECHNICAL

SIRA DESIGN CONSIDERATIONS

- Standalone versions supplied complete with 3M suspension kit.
- Suspension kits sold separately for continuous run versions.

- Autotest LA3 emergency and DALI Dimming will use common DALI BUS Cable. LA3 emergency can not be combined with other dimming types.
- Bi-Directional versions provide 60% down light and 40% up light.
- Bi-Directional variants use two drivers and therefore DALI variants require two addresses.
- Integral sensors are only available in the luminaire, one required per luminaire.
- 1200mm variants can not accommodate both integral emergency and integral sensor.

>

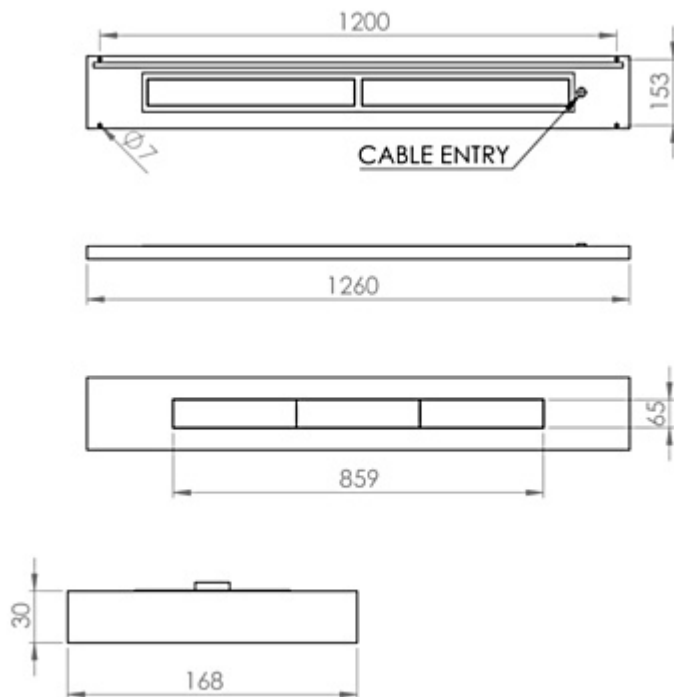

Sira 1200mm

>

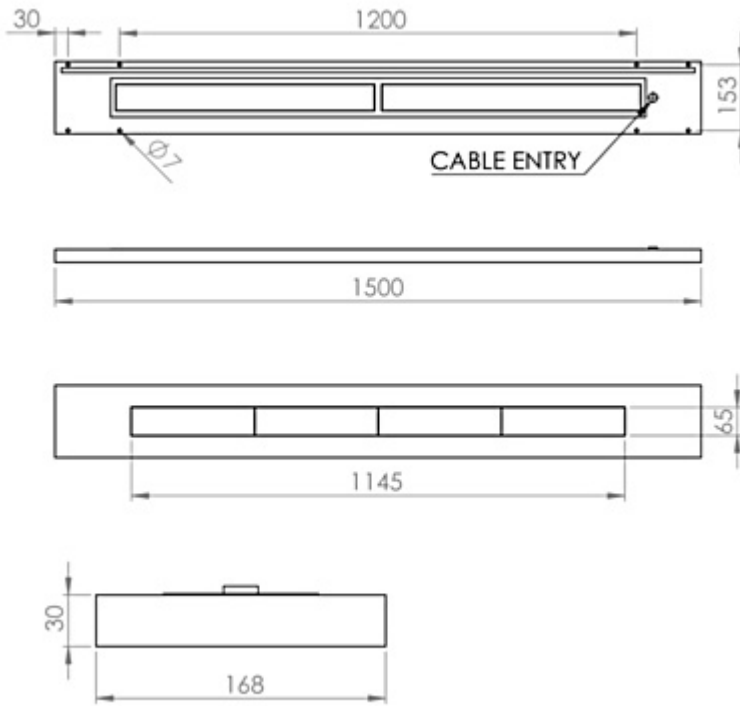

Sira 1500mm

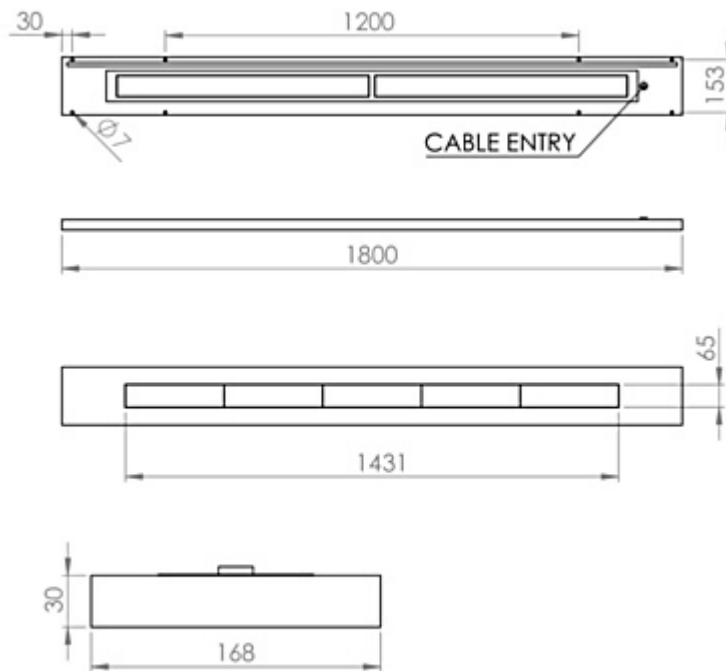

Sira 1800mm

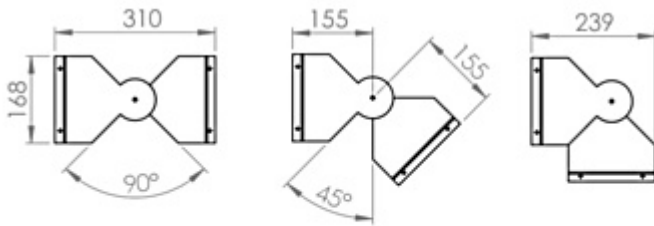

INFINITE ADJUSTMENT BETWEEN 0 - 90 DEGREES

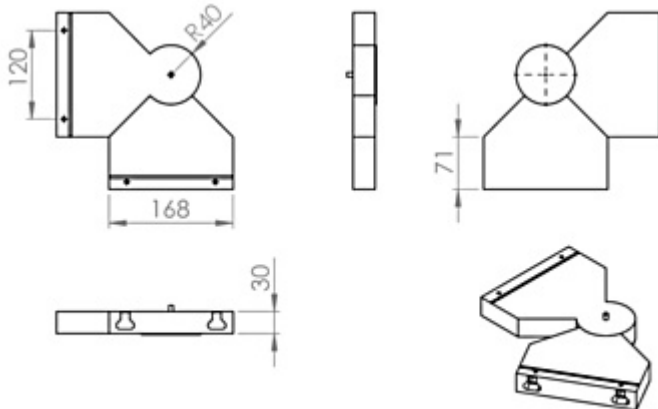

Sira Adjustable Corner

WARRANTY

At Dextra our commitment to service has been at the forefront throughout our history spanning more than forty years in the UK lighting market. Our service ethos extends beyond design and delivery, we believe supporting your installation throughout the warranty period is equally crucial, whilst the strength and longevity of Dextra Group provides peace of mind that our warranty will be supported throughout.

The Dextra range is supplied with a five year warranty commencing from the date of delivery. During the first three years defects will be repaired on site and the warranty will include both parts and labour. For the final two years drivers, emergency modules, wireless modules, sensors and LED circuits will be supplied free of charge to replace defective components, labour and other associated costs are not included.

Certain ranges and components are subject to exemptions:

- Lithium batteries are provided with a five year warranty. During the first three years defects will be repaired on site and the warranty will include both parts and labour. For the final two years replacement batteries will be supplied free of charge to replace defective components. Five year warranty became effective as of 03/02/25, Lithium emergency luminaires supplied prior to this date are supported with a three year on site warranty only. Labour and other associated costs are not included. Nickel Metal Hydride and Nickel Cadmium batteries are provided with a one year warranty for parts and labour.

- Emergency luminaires including AME LED, EXI LED, EXI2 LED, EXI Track, HBE LED, HBE2 LED, OAT2 LED, OEZ LED and Twinspot with Nickel Metal Hydride batteries are supplied with a one year warranty for parts and labour. Lithium variants of these ranges are supplied with a three year warranty for parts and labour with the exception of the AME2, EXI3, HBE3 and TWS IP65 L7 ranges which are supplied with a one year parts and labour warranty. TWS IP65 L7 in autotest and wireless variants are supplied with the standard three year lithium battery warranty.
- Protec Micro, PTECF7 Fire Rated Downlights, Serenus and the Opus Sconce are provided with a five year replacement luminaire only warranty. Protec FR Fire Rated Downlights are provided with a 2 year replacement luminaire only warranty.
- Controls systems such as standalone sensors, switches, marshalling boxes and cabling are provided with a one year warranty for both parts and labour. DALI control systems are provided with a two year warranty for both parts and labour.
- LEDextra ranges are supplied with a three year parts or replacement luminaire only warranty with the exception of the IMPR RGBW, the Runway RGBW, the MOD RGBW, Tanek RGBW and the DexRing. These five ranges are supplied with our standard five year warranty during which defects within the first three years will be repaired on site and the warranty includes both parts and labour. For the final two years free of charge replacement components only will be supplied to rectify any failures but labour and other associated costs are not included.
- LEDEX ranges are supplied with a three year replacement luminaire only warranty.
- The Decorative Pendant ranges, Bebo, Dene, Nova, Fino and Stix are supplied with a 3 year replacement luminaire only warranty.

All warranties are subject to correct use of the product and will be invalidated by misuse, for example incorrect installation, unsuitable environmental conditions or incorrect maintenance. It is the duty of the customer to ensure that all the fault lies with the luminaire prior to requesting replacement parts or site repairs. In the event that no defect is found with the product our costs for attending site will be recharged to the customer and credit will not be issued against returned products. No consequential losses incurred resulting from any defect with our product will be reimbursed.

Given the nature of LED technology a small percentage of LEDs may fail during the lifetime of a luminaire, this does not cause a reduction in lumen output. As such LED luminaires are only deemed to be faulty for warranty purposes when in excess of ten percent of LEDs have failed in a single luminaire.

On site repair of products under warranty will be undertaken during normal working hours, 9am to 5pm Monday to Friday, and will require unrestricted access to luminaires. Where required Dextra will provide access equipment to carry out repairs at height, should luminaires have been installed in locations where reasonable provision for maintenance access has not been made we reserve the right to supply replacement product only. On site warranty repairs will only be undertaken on the mainland of the UK and Ireland, in all other locations replacement product only will be provided.

If you require any assistance with regards to our products please contact our Customer Services department on 01747 858100.

ORDER CODES

LUMINAIRE

Sira Suspended Continuous Run

Downlight

Code	Description	Power	Llm/W
SIR 12L30 ST	Sira Start, 1260mm, 2,877lm, Colour 84	20.4W	141
SIR 12L30 TW	Sira Through, 1260mm, 2,877lm, Colour 84	20.4W	141
SIR 12L30 ER	Sira End, 1260mm, 2,877lm, Colour 84	20.4W	141
SIR 15L37 ST	Sira Start, 1500mm, 3,548lm, Colour 84	24.1W	147
SIR 15L37 TW	Sira Through, 1500mm, 3,548lm, Colour 84	24.1W	147
SIR 15L37 ER	Sira End, 1500mm, 3,548lm, Colour 84	24.1W	147
SIR 18L45 ST	Sira Start, 1800mm, 4,316lm, Colour 84	20.4W	141
SIR 18L45 TW	Sira Through, 1800mm, 4,316lm, Colour 84	20.4W	141
SIR 18L45 ER	Sira End, 1800mm, 4,316lm, Colour 84	20.4W	141

Bi-Directional

Code	Description	Power	Llm/W
SIRBD 12L40 ST	Sira Start, 1260mm, 3,750lm, Bi-Directional, Colour 84	24.2W	154
SIRBD 12L40 ER	Sira End, 1260mm, 3,750lm, Bi-Directional, Colour 84	24.2W	154
SIRBD 12L40 TW	Sira Through, 1260mm, 3,750lm, Bi-Directional, Colour 84	24.2W	154
SIRBD 15L50 ST	Sira Start, 1500mm, 4,697lm, Bi-Directional, Colour 84	32.0W	146
SIRBD 15L50 TW	Sira Through, 1500mm, 4,697lm, Bi-Directional, Colour 84	32.0W	146
SIRBD 15L50 ER	Sira End, 1500mm, 4,697lm, Bi-Directional, Colour 84	32.0W	146
SIRBD 18L60 ST	Sira Start, 1800mm, 5,636lm, Bi-Directional, Colour 84	39.4W	143
SIRBD 18L60 TW	Sira Through, 1800mm, 5,636lm, Bi-Directional, Colour 84	39.4W	143
SIRBD 18L60 ER	Sira End, 1800mm, 5,636lm, Bi-Directional, Colour 84	39.4W	143

DIMMING

Code	Description
A	DALI Digital Addressable Lighting Interface
S	Switch Dimming
D	DSI Digital Dimming
H	HFR Analogue 1-10v
C	Bi-Level Dimming For Standalone Switched Sensor

Please click [here](#) for full details on our white tunable offer.

Please refer to the Sira Design Consideration notes in the Technical section prior to placing your order.

CONTROL

Code	Description
R44	Reacta 44, Presence & Daylight, 2.5-7M
RAS	Reacta-Air Bluetooth, Wireless, Presence & Daylight, 2.5-3M
RLI	Reacta-Link, Wireless Enabled Luminaire
RLS	Reacta-Link Wireless, Presence & Daylight, 2.5M-5M
RC	Reacta-Control, Wireless Enabled Luminaire
RCS	Reacta-Control Wireless, Presence & Daylight, 2.5-4M

EMERGENCY

Code	Description
------	-------------

LE3	Lithium Standard Emergency 3 Hour
LS3	Lithium Selftest Emergency 3 Hour
LA3	Lithium Autotest Emergency 3 Hour
LSTR	Lithium Reacta-Link Emergency 3 Hour
LA3RC	Lithium Reacta-Control Emergency 3 Hour

Please refer to the Sira Design Consideration notes in the Technical section prior to placing your order.

MISCELLANEOUS

Code	Description
C**	Select Colour Temperature and Rendering; C83, C84, C85, C865, C93, C94
GY	Grey Finish
B	Black Finish
SUSP RBX SIR ELL 3M BF X2	3M Suspension Kit
LSF	Low Smoke Zero Halogen
SIR COR TW	Sira Through Corner, Adjustable
SIR BLIND 300 TW	Sira Continuous Run, 300mm 6 pole through wire blind unit
SIR BLIND 1260 TW	Sira Through 1260mm Blind, 6 Pole
SIR BLIND 1500 TW	Sira Through 1500mm Blind, 6 Pole
SIR EC	Sira End Cap Pair, One Per Run
SIR JOINER	Sira Join (Use where new power feed required mid run)

220-240V / 50-60Hz
IP20
IK07



WARNING: Luminaire must be earthed. Risk of electric shock from LED boards if operated with cover removed. Installation / operation outside of luminaires intended scope invalidates warranty. Suitable only for domestic / light industrial / industrial applications within the scope of EN55015. Tested to compliance with BSEN 60598: specification for general requirements and tests. Must be installed by a suitably qualified person in accordance with all relevant legislation. Ambient operating temperature of 0°C to 25°C. If maximum operating temperature is exceeded luminaire will automatically dim / switch off. Terminal blocks are rated to 16A unless stated otherwise. The light source contained in this luminaire shall only be replaced by the manufacturer or his service agent or a similar qualified person. **LUMINAIRES WITH EMERGENCY PACK:** When supply is isolated battery output terminals may be live if battery is connected. Isolate mains and battery before servicing. Emergency luminaires require unswitched live connection taken from same phase as switched supply. When unswitched supply is connected status indicator illuminates green, when unswitched supply is disconnected indicator extinguishes and luminaire operates in emergency mode. 24 hour charge period required before undertaking full discharge test. Emergency test sheets provided should be used to record all emergency tests. Batteries should be replaced when 3 hour duration is not met. Excessive switching of permanent live may result in premature battery failure. Battery electrolyte can be harmful to eyes / open wounds, do not puncture, if electrolyte touches skin / eyes flush with water. Do not incinerate batteries.

Terminal Labelling:	
Power	
L1	Switched Live
E	Earth
N	Neutral
Emergency	
L2	Unswitched Live
DA/AT3	DALI Autotest
DA/AT3	DALI Autotest
Dimming	
-/D1/DA	Analogue/DSI/DALI
+/D2/DA	Analogue/DSI/DALI
L3	Switch Dim / Corridor Function

1.

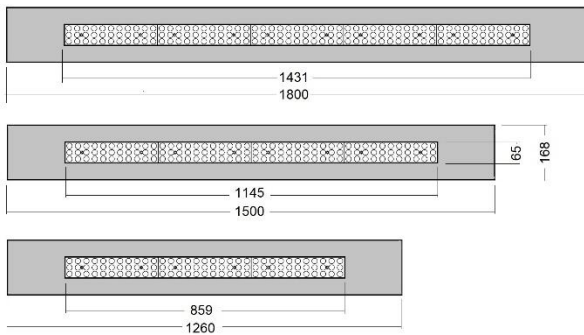

Luminaire comes in 3 length options

2.

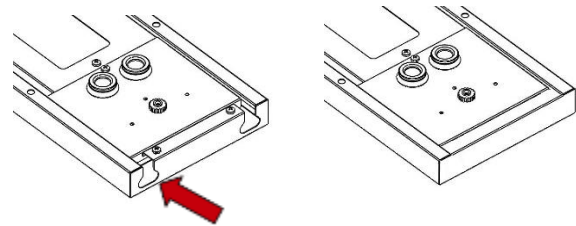

Through-wire (ST / TW / ER)

Standalone

Check fitting type is correct before installation – through-wire versions have cable cut-outs in ends and threaded holes for joining bracket / end plate

3.

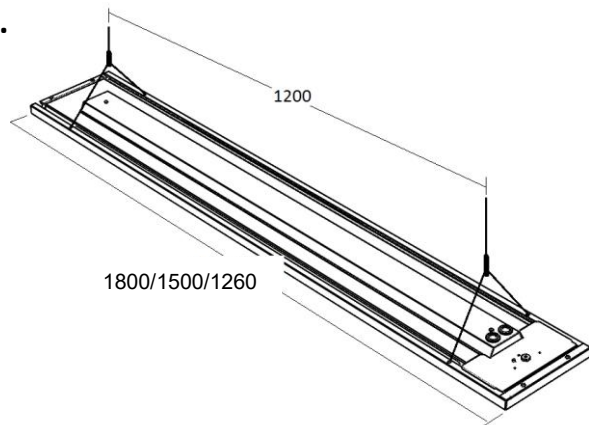

As stand-alone, suspension centres are 1200mm in all lengths

4.

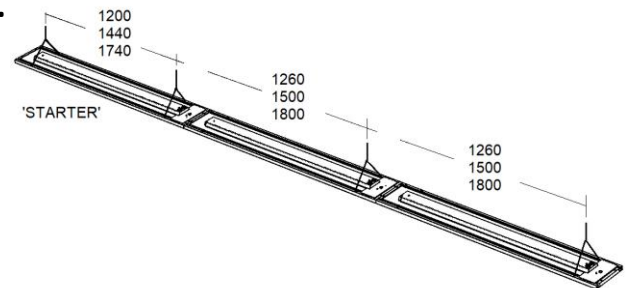

When mounting continuously, STARTER should have x2 suspensions. Subsequent TW fittings require just one... If preferred, each fitting CAN have 2 suspensions fitted (at same centres as STARTER). NOTE, if custom infill pieces are specified, positions of suspensions will be different – always check before installation!!

5.

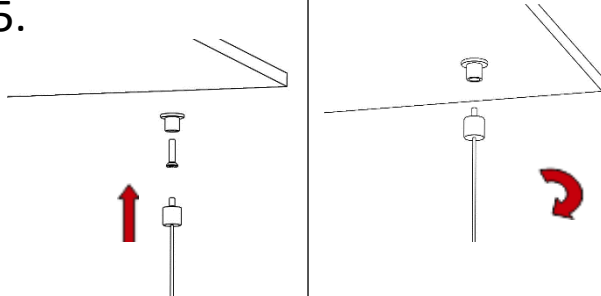

Secure suspension drops as shown in marked positions.

Screw suspension wire and clutch into ceiling fixture.

6.

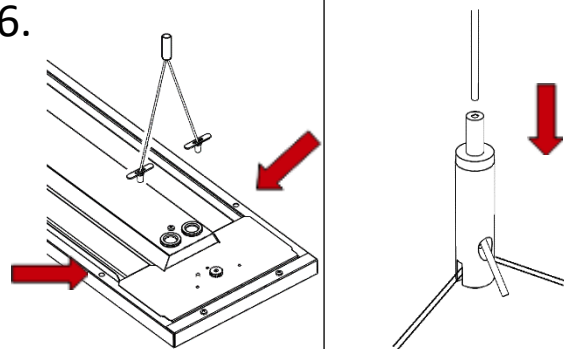

Insert toggles of Y suspension kit in to 7mm holes in luminaire

To attach to main wire, depress top of clutch & insert wire

Sira Installation

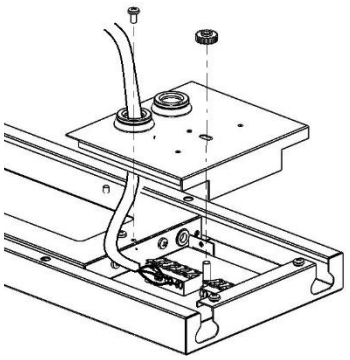
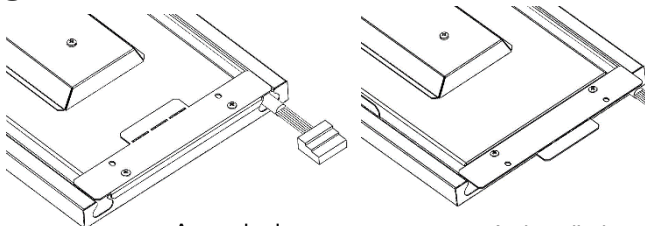
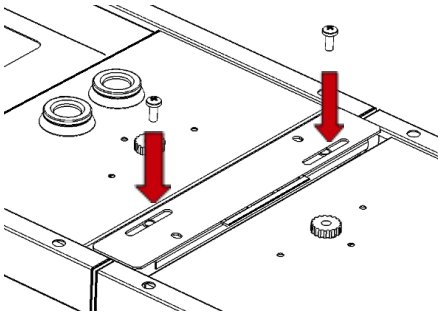
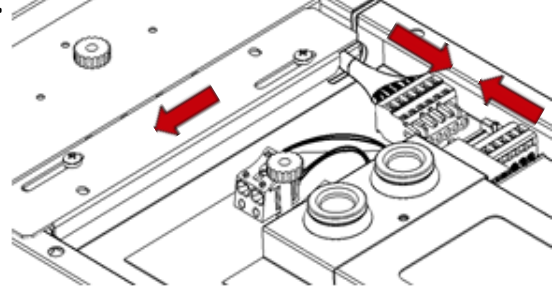
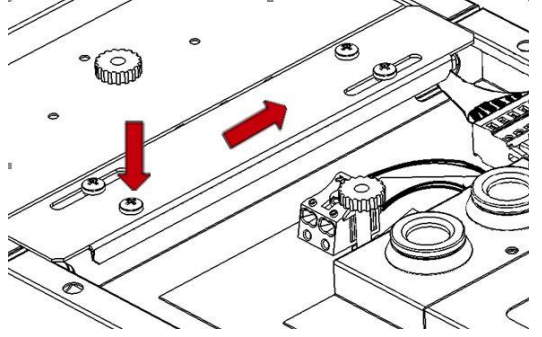
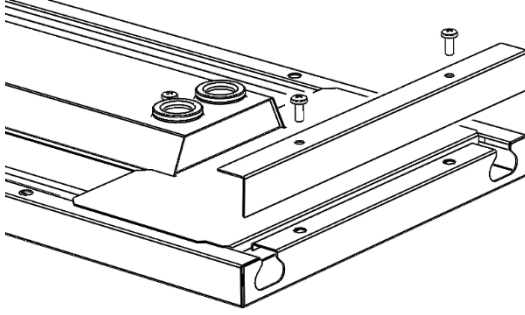
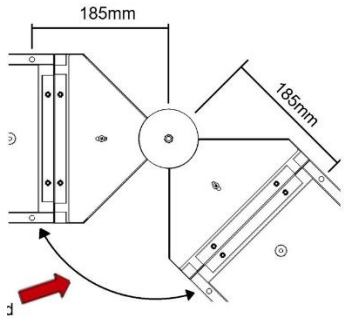
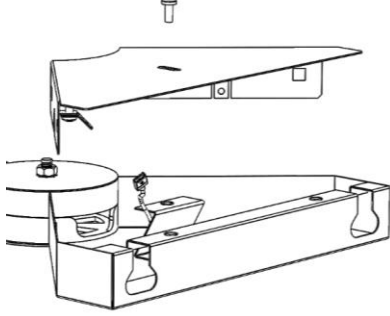
<p>7.</p>  <p>To make electrical connection, loosen thumbnut & M4 screw, remove / lift away cover plate. Pass cable through entry gland and connect to appropriate terminations</p>	<p>8.</p>  <p>As packed As installed</p> <p>Fittings are supplied with joining brackets reversed (1) – ensure both screws are removed / brackets rotated / re-fixed ready to connect to next fitting (2)</p>
<p>9.</p>  <p>When mounting continuously, fit joining brackets as shown using x2 M4x10 screws in the slots.</p>	<p>10.</p>  <p>Slide the joining bracket to one side and drop the through-wire loom into the next fitting. The through wire cable should be connected and located as shown (6-core as standard).</p>
<p>11.</p>  <p>Once through-wire loom is connected, slide the joining bracket across to cover the loom and secure with remaining x2 M4x10 screws as shown.</p>	<p>12.</p>  <p>At Start and End of runs, fit ER cap (use x2 M4x10 screws (supplied))</p>
<p>13. Corner Installation</p> <p>Install BOTH luminaires first! MARK OUT CAREFULLY</p> <p>Fit joining brackets (remove covers first)</p> <p>Connect through cable</p> <p>Ensure earth is connected to covers</p> 	<p>14.</p>  <p>To complete, re-fit top covers (single M4x10 per cover)</p>

Maintenance

- 1 Disconnect luminaire before undertaking any maintenance or cleaning.
- 2 Cleaning should be undertaken on external parts of the luminaire only using a slightly damp lint free cloth.
- 3 To access fitting use a pan pozi screwdriver to remove screw. In an anticlockwise motion remove thumb nit to release end plates. Repeat action on opposite end.
- 4 Using a pan pozi screwdriver remove retaining brackets. Gear tray will now be removable.
- 5 Use a pan pozi screwdriver to remove components and LED tray.
- 6 Please contact Dextra for assistance with spare component supply.

