



PRODUCT SPECIFICATION

RUBIX 1



INTRODUCTION

The Rubix 1 has been designed to offer retailers a high quality LED alternative to the traditional GU10 downlighter. The small optically controlled single cell helps to minimise glare off axis and the side mounted retractive spring clips enable rapid installation on site. Available in two colour temperatures and with a choice of coloured cell bezels to match in with your corporate branding, this is the latest addition to the extensive Rubix product family. Infill rings are available on request for retrofit applications to ensure suitability for existing ceiling cut outs.

**UK
CA** CE IP20 TM21: L90>60K HOURS / L80>90K HOURS 3 STEP MACADAM ELLIPSE

APPLICATION

- Commercial / Offices
 - Hotel / Leisure
 - Retail
-

SPECIFICATION

CONSTRUCTION

- Housing: 0.7mm CR4 steel
- Finish: Polyester powder painted BS 00E55 matt white 60% gloss
- Diffuser: Injection moulded high transmission opal polycarbonate cell with miro silver aluminium inserts and injection moulded clip on bezel
- IP20

PERFORMANCE

- Part L2 compliant
- BSEN 12464-1:2011 3000 Candela 65° and UGR 19 compliance
- 3SCDM Three step Macadams ellipse
- TM21: L90>60K Hours / L80>90K Hours
- Up to 80 luminaire lumens per circuit Watt.

ENVIRONMENTAL

- Designed to allow simple replacement of components with commonly available tools in compliance with the Eco Design Directive, please see the installation leaflet for maintenance instructions.
- Powered by European branded drivers and emergency modules ensuring replacement parts are easily sourced.
- Every luminaire is labelled with a unique ID number allowing easy identification of spare parts for the lifetime of the product.
- Contains no single use plastics or polystyrene packaging.
- Supplied in plain card boxes with paper tape ensuring packaging is easily recycled.
- Designed to allow simple disassembly for end of life recycling.
- UK based manufacturing providing local support throughout the product lifetime and minimising transportation miles.

EMERGENCY

- Not available with emergency

CONTROL

- Optional compatibility with a range of dimming systems including DALI, DSI and Switch Dimming

INSTALLATION

- Suitable for plasterboard installation
- Suitable for mineral fibre ceiling tile installation
- Suitable for metal ceiling tile installation

VARIATIONS

- Available with a wide range of colour temperatures and renderings
- Available with a range of cell colours

IMAGES

PRODUCT IMAGES



Rubix 1

TECHNICAL

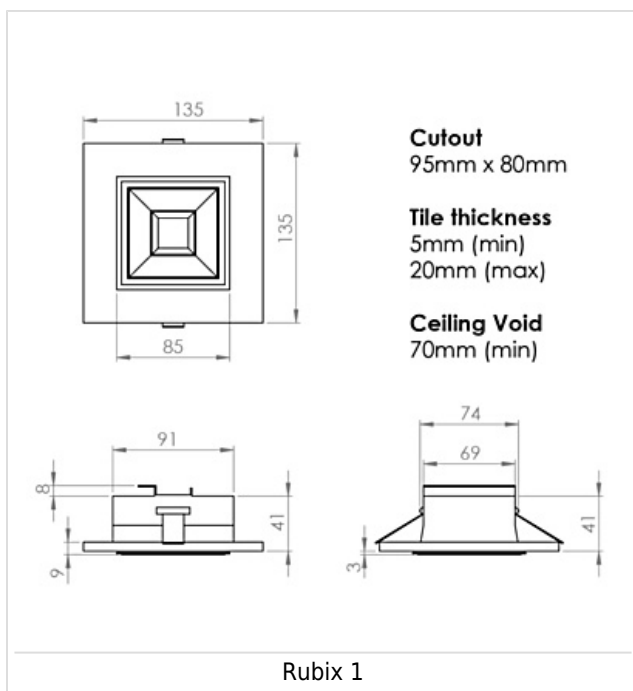

WARRANTY

At Dextra our commitment to service has been at the forefront throughout our history spanning more than forty years in the UK lighting market. Our service ethos extends beyond design and delivery, we believe supporting your installation throughout the warranty period is equally crucial, whilst the strength and longevity of Dextra Group provides peace of mind

that our warranty will be supported throughout.

The Dextra range is supplied with a five year warranty commencing from the date of delivery. During the first three years defects will be repaired on site and the warranty will include both parts and labour. For the final two years drivers, emergency modules, wireless modules, sensors and LED circuits will be supplied free of charge to replace defective components, labour and other associated costs are not included.

Certain ranges and components are subject to exemptions:

- Lithium batteries are provided with a three year warranty for parts and labour. Nickel Metal Hydride and Nickel Cadmium batteries are provided with a one year warranty for parts and labour.
- Emergency luminaires including AME LED, EXI LED, EXI2 LED, EXI Track, HBE LED, HBE2 LED, OAT2 LED, OEZ LED and Twinspot with Nickel Metal Hydride batteries are supplied with a one year warranty for parts and labour. Lithium variants of these ranges are supplied with a three year warranty for parts and labour with the exception of the AME2, EXI3, HBE3 and TWS IP65 L7 ranges which are supplied with a one year parts and labour warranty. TWS IP65 L7 in autotest and wireless variants are supplied with the standard three year lithium battery warranty.
- Protec Micro, PTECF7 Fire Rated Downlights, Serenus and the Opus Sconce are provided with a five year replacement luminaire only warranty. Protec FR Fire Rated Downlights are provided with a 2 year replacement luminaire only warranty.
- Controls systems such as standalone sensors, switches, marshalling boxes and cabling are provided with a one year warranty for both parts and labour. DALI control systems are provided with a two year warranty for both parts and labour.
- LEDextra ranges are supplied with a three year parts or replacement luminaire only warranty with the exception of the IMPR RGBW, the Runway RGBW, the MOD RGBW and the Tanek RGBW. These three ranges are supplied with our standard five year warranty during which defects within the first three years will be repaired on site and the warranty includes both parts and labour. For the final two years free of charge replacement components only will be supplied to rectify any failures but labour and other associated costs are not included.
- LEDEX ranges are supplied with a three year replacement luminaire only warranty.
- The Decorative Pendant ranges, Bebo, Dene, Nova, Fino and Stix are supplied with a 3 year replacement luminaire only warranty.

All warranties are subject to correct use of the product and will be invalidated by misuse, for example incorrect installation, unsuitable environmental conditions or incorrect maintenance. It is the duty of the customer to ensure that all the fault lies with the luminaire prior to requesting replacement parts or site repairs. In the event that no defect is found with the product our costs for attending site will be recharged to the customer and credit will not be issued against returned products. No consequential losses incurred resulting from any defect with our product will be reimbursed.

Given the nature of LED technology a small percentage of LEDs may fail during the lifetime of a luminaire, this does not cause a reduction in lumen output. As such LED luminaires are only deemed to be faulty for warranty purposes when in excess of ten percent of LEDs have failed in a single luminaire

On site repair of products under warranty will be undertaken during normal working hours, 9am to 5pm Monday to Friday, and will require unrestricted access to luminaires. Where required Dextra will provide access equipment to carry out repairs at height, should luminaires have been installed in locations where reasonable provision for maintenance access has not been made we reserve the right to supply replacement product only.

If you require any assistance with regards to our products please contact our Customer Services department on 01747 858100.

[DOWNLOAD WARRANTY PDF](#)

ORDER CODES

LUMINAIRE

Code	Description	Power	Llm/W
RBXPFL 11L6	Rubix 1, Pull Up, 135x135mm, 467lm, Opal Cell, Colour 84	5.8W	80

OPTIC

Code	Description
BLK	Black Cell
BLE	Blue Cell
ORA	Orange Cell
RED	Red Cell

Other cell colours are available on request subject to minimum order quantities and extended delivery times.

CONTROL

Code	Description
RLI	Reacta-Link, Wireless Enabled Luminaire
RC	Reacta-Control, Wireless Enabled Luminaire
RCSS	Reacta-Control Standalone Sensor, Presence & Daylight 2.5-4M, Use with RC Luminaires
RLS REMOTE SENSOR	Reacta-Link Standalone Sensor, Presence, 2.5-4M, Use with RLI Luminaires (sold separately)
RAD	Reacta-Air, Wireless Enabled Luminaire
RASS	Reacta-Air Standalone Sensor, Presence, 2.5-4M, Use with RAD Luminaires (sold separately)
RASSD	Reacta-Air Standalone Sensor, Presence & Daylight, 2.5-4M, Use with RAD Luminaires (sold separately)

*Sensor supplied with luminaire for installation in adjacent ceiling tile.

Please click [here](#) for full details on our wireless controls.

MISCELLANEOUS

Code	Description
C**	Select Colour Temperature and Rendering; C83, C84, C85, C865, C93, C94
BL	Black Finish
GY	Grey Finish
4PM	4 Pole Panel Mount
6PM	6 Pole Panel Mount
INFILL	Infill Rings to Suit Over Size Ceiling Cut Out, Please Specify Size when Ordering.
LSF	Low Smoke Zero Halogen