

PRODUCT SPECIFICATION

RUBINI RECESSED



INTRODUCTION

Where lighting must be both discreet and attractive, the Rubini Recessed provides the optimum solution with its small form factor combined with a modern and attractive cellular design. With excellent glare control of UGR 16 and cutting edge efficiency in excess of 160 luminaire lumens per watt, the Rubini Recessed offers superb efficiency and architectural appeal. With an extruded aluminium housing, injection moulded cellular baffle and front bezel and lensed optic to ensure consistent optical performance with excellent glare control and efficiency the Rubini Recessed has been designed without compromise in materials or performance.

The Rubini Recessed sits flush in the ceiling and is ideal for both general and task lighting. White or black housing and white, black or copper cellular baffle options are available ensuring that the Rubini can blend into a range of architectural styles, and is available in two housing sizes, 300mm 7 cell or 600mm 14 cell as well as a range of dimmable options including Switch Dim, DSI, HFR or DALI.



CE IP20 TM21: L90>60K HOURS / L80>90K HOURS 3 STEP MACADAM ELLIPSE

APPLICATION

- Commercial / Offices
- Education
- Hotel / Leisure
- Office
- Retail

SPECIFICATION

CONSTRUCTION

- Housing: High pressure die cast aluminium
- Finish: Polyester powder painted BS 00E55 matt white 60% gloss
- Finish: Polyester powder painted RAL 9005 matt black
- Lens: Injection moulded PMMA 80° with baffle in RAL9005 matt black, RAL 9016 matt white or copper
- IP20

PERFORMANCE

- Part L2 compliant
- BSEN 12464-1:2011 3000 Candela 65° and UGR 19 compliance
- 3SCDM Three step Macadams ellipse
- TM21: L90>60K Hours / L80>90K Hours
- Up to 145 luminaire lumens per circuit Watt.

ENVIRONMENTAL

- Designed to allow simple replacement of components with commonly available tools in compliance with the Eco Design Directive, please see the installation leaflet for maintenance instructions.
- Powered by European branded drivers and emergency modules ensuring replacement parts are easily sourced.
- Every luminaire is labelled with a unique ID number allowing easy identification of spare parts for the lifetime of the product.
- Contains no single use plastics or polystyrene packaging.
- Supplied in plain card boxes with paper tape ensuring packaging is easily recycled.
- Designed to allow simple disassembly for end of life recycling.
- UK based manufacturing providing local support throughout the product lifetime and minimising transportation miles.

EMERGENCY

- Not available with emergency

CONTROL

- Optional compatibility with a range of dimming systems including DALI, DSI and Switch Dimming
- Optional integral Reacta-Link for integration with Reacta-Link wireless installations
- Optional integral Reacta-Control for integration with Reacta-Control wireless installations

INSTALLATION

- Suitable for plasterboard installation
- Suitable for mineral fibre ceiling tile installation
- Suitable for metal ceiling tile installation
- Alugrid 08 and 16 compatible options available. Please see miscellaneous ordering codes.

VARIATIONS

- Available with a wide range of colour temperatures and renderings

- Available in a range of housing sizes and lumen outputs
- Available in white or black finishes

IMAGES

PRODUCT IMAGES



Rubini Recessed White Bezel White Baffle

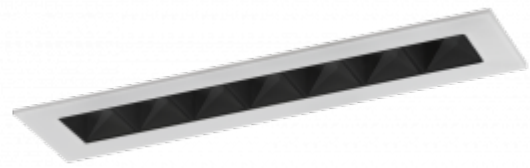

Rubini Recessed White Bezel Black Baffle

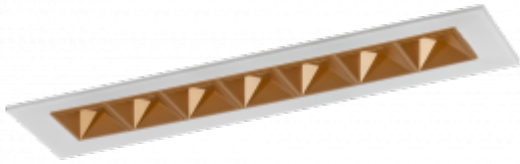

Rubini Recessed White Bezel Copper Baffle



Rubini Recessed Black Bezel White Baffle



Rubini Recessed Black Bezel Black Baffle



Rubini Recessed Black Bezel Copper Baffle

PROJECT IMAGES



TECHNICAL

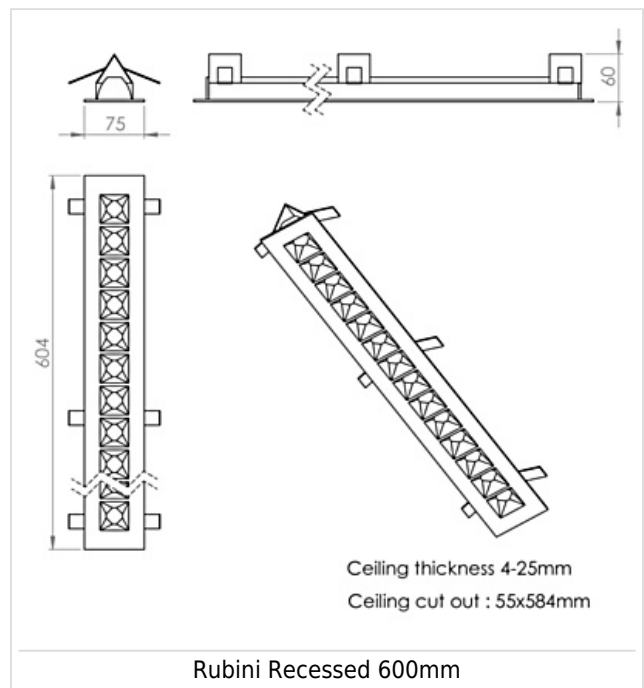
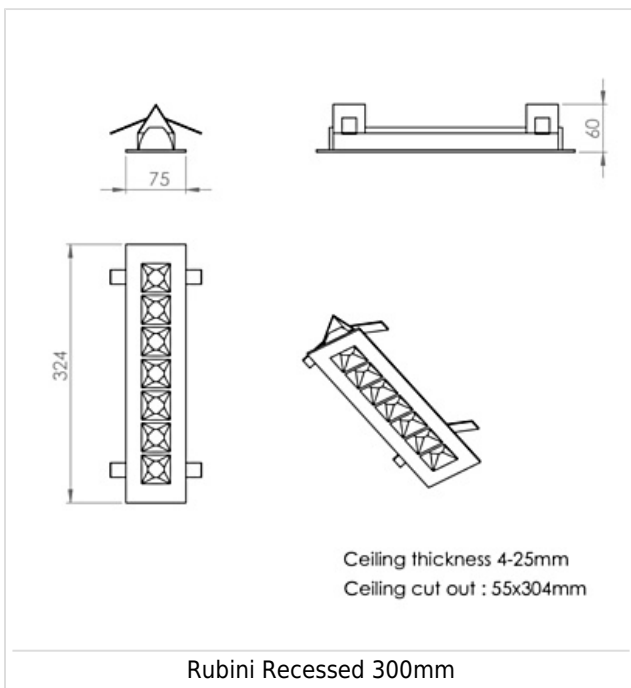

WARRANTY

At Dextra our commitment to service has been at the forefront throughout our history spanning more than forty years in the UK lighting market. Our service ethos extends beyond design and delivery, we believe supporting your installation throughout the warranty period is equally crucial, whilst the strength and longevity of Dextra Group provides peace of mind that our warranty will be supported throughout.

The Dextra range is supplied with a five year warranty commencing from the date of delivery. During the first three years defects will be repaired on site and the warranty will include both parts and labour. For the final two years drivers, emergency modules, wireless modules, sensors and LED circuits will be supplied free of charge to replace defective components, labour and other associated costs are not included.

Certain ranges and components are subject to exemptions:

- Lithium batteries are provided with a three year warranty for parts and labour. Nickel Metal Hydride and Nickel Cadmium batteries are provided with a one year warranty for parts and labour.
- Emergency luminaires including AME LED, EXI LED, EXI2 LED, EXI Track, HBE LED, HBE2 LED, OAT2 LED, OEZ LED and Twinspot with Nickel Metal Hydride batteries are supplied with a one year warranty for parts and labour. Lithium variants of these ranges are supplied with a three year warranty for parts and labour with the exception of the AME2, EXI3, HBE3 and TWS IP65 L7 ranges which are supplied with a one year parts and labour warranty. TWS IP65 L7 in autotest and wireless variants are supplied with the standard three year lithium battery warranty.
- Protec Micro, PTECF7 Fire Rated Downlights, Serenus and the Opus Sconce are provided with a five year replacement luminaire only warranty. Protec FR Fire Rated Downlights are provided with a 2 year replacement luminaire only warranty.
- Controls systems such as standalone sensors, switches, marshalling boxes and cabling are provided with a one year warranty for both parts and labour. DALI control systems are provided with a two year warranty for both parts and labour.
- LEDextra ranges are supplied with a three year parts or replacement luminaire only warranty with the exception of the IMPR RGBW, the Runway RGBW, the MOD RGBW and the Tanek RGBW. These three ranges are supplied with our standard five year warranty during which defects within the first three years will be repaired on site and the warranty includes both parts and labour. For the final two years free of charge replacement components only will be supplied to rectify any failures but labour and other associated costs are not included.
- LEDEX ranges are supplied with a three year replacement luminaire only warranty.
- The Decorative Pendant ranges, Bebo, Dene, Nova, Fino and Stix are supplied with a 3 year replacement luminaire only warranty.

All warranties are subject to correct use of the product and will be invalidated by misuse, for example incorrect installation, unsuitable environmental conditions or incorrect maintenance. It is the duty of the customer to ensure that all the fault lies with the luminaire prior to requesting replacement parts or site repairs. In the event that no defect is found with the product our costs for attending site will be recharged to the customer and credit will not be issued against returned products. No consequential losses incurred resulting from any defect with our product will be reimbursed.

Given the nature of LED technology a small percentage of LEDs may fail during the lifetime of a luminaire, this does not cause a reduction in lumen output. As such LED luminaires are only deemed to be faulty for warranty purposes when in excess of ten percent of LEDs have failed in a single luminaire

On site repair of products under warranty will be undertaken during normal working hours, 9am to 5pm Monday to Friday, and will require unrestricted access to luminaires. Where required Dextra will provide access equipment to carry out repairs at height, should luminaires have been installed in locations where reasonable provision for maintenance access has not been made we reserve the right to supply replacement product only.

If you require any assistance with regards to our products please contact our Customer Services department on 01747 858100.

[DOWNLOAD WARRANTY PDF](#)

ORDER CODES

LUMINAIRE

Code	Description	Power	Llm/W
RBNR7 L11 **	Rubini Recessed, 7 Cell, 300mm, 1,032lm, Colour 84	7.5W	138
RBNR14 L23 **	Rubini Recessed, 14 Cell, 600mm, 2,063lm, Colour 84	14.2W	145

For Alugrid compatible versions please specify lay-in luminaire with correct ALU suffix shown in miscellaneous ordering codes

**Select housing and baffle colour from Options

Luminaire lumen values based on white baffle

600mm variants are only suitable for installation in 15mm exposed T ceilings. Do not specify for 24mm exposed T ceilings

COLOUR

Code	Description
WW	White Housing / White Baffle
WB	White Housing / Black Baffle
WC	White Housing / Copper Baffle
BB	Black Housing / Black Baffle
BW	Black Housing / White Baffle
BC	Black Housing / Copper Baffle

DIMMING

Code	Description
A	DALI Digital Addressable Lighting Interface
S	Switch Dimming
D	DSI Digital Dimming
H	HFR Analogue 1-10v
C	Bi-Level Dimming For Standalone Switched Sensor

CONTROL

Code	Description
RC	Reacta-Control, Wireless Enabled Luminaire

MISCELLANEOUS

Code	Description
C**	Select Colour Temperature and Rendering; C83, C84, C85, C865, C93, C94
4PM	4 Pole Panel Mount
6PM	6 Pole Panel Mount
INFILL	Infill Rings to Suit Over Size Ceiling Cut Out, Please Specify Size when Ordering.
LSF	Low Smoke Zero Halogen
ALU16	Alugrid 15/16 Ceiling Compatible

ALU08

Alugrid 15/08 Ceiling Compatible
