



# PRODUCT SPECIFICATION

---

PROTEC



## INTRODUCTION

The Protec is the most versatile downlight in the range with a selection of attachments allowing the product to be personalised to suit most applications such as receptions, offices, retail, corridors, meeting rooms, airports, educational establishments and healthcare. The Protec is available with two reflector options, coloured ring inserts to match corporate themes, drop glass and ring attachments, IP rated covers for bathrooms and wet areas including external under canopy applications and opal or microprism diffuser variants where glare compliance is required. Attachments are easily replaced allowing luminaires to be updated in line with refurbishment avoiding the cost and waste of luminaire replacement. The Protec is also available with a wide range of dimming variants and integral lithium emergency ensuring compatibility with all controls and safety requirements. We offer a range of wireless control systems providing localised grouping and control as well as comprehensive wireless solutions allowing both standard and emergency luminaires to be centrally monitored. A wide selection of infill rings are available to ensure suitability for existing ceiling cut outs.



CE IP20 IP44 IP65 TM21: L90>60K HOURS / L80>90K HOURS 3 STEP MACADAM ELLIPSE

## APPLICATION

- Canteen
- Commercial / Offices
- Corridor

- › Education
  - › Healthcare / Social Housing
  - › Hotel / Leisure
  - › Industrial / Manufacturing
  - › Office
  - › Retail
  - › Toilet
  - › Transport
  - › Warehouse / Storage
- 

## SPECIFICATION

---

### CONSTRUCTION

- › Housing: Injection moulded ABS
- › Finish: White, grey or black bezels
- › Reflector: Specular aluminium
- › Reflector: Semi specular aluminium
- › ISO 7010 or Euro Norm Legends with all directional arrow options.
- › IP20
- › IP44
- › IP65

### PERFORMANCE

- › Part L2 compliant
- › BSEN 12464-1:2011 3000 Candela 65° and UGR 19 compliance
- › 3SCDM Three step Macadams ellipse
- › TM21: L90>60K Hours / L80>90K Hours
- › Up to 117 luminaire lumens per circuit Watt.

### ENVIRONMENTAL

- › Designed to allow simple replacement of components with commonly available tools in compliance with the Eco Design Directive, please see the installation leaflet for maintenance instructions.
- › Powered by European branded drivers and emergency modules ensuring replacement parts are easily sourced.
- › Every luminaire is labelled with a unique ID number allowing easy identification of spare parts for the lifetime of the product.
- › Contains no single use plastics or polystyrene packaging.

- Supplied in plain card boxes with paper tape ensuring packaging is easily recycled.
- Designed to allow simple disassembly for end of life recycling.
- UK based manufacturing providing local support throughout the product lifetime and minimising transportation miles.

### EMERGENCY

- Available with optional standard, self test and autotest integral emergency with lithium batteries for extended warranty and lifetime.
- Optional Reacta-Link wireless emergency for automated centralised reporting.
- Optional Reacta-Control wireless emergency for automated centralised reporting.
- Optional central battery changeover relay

### CONTROL

- Optional compatibility with a range of dimming systems including DALI, DSI and Switch Dimming
- Optional White tunable
- Optional integral Reacta-Link for integration with Reacta-Link wireless installations
- Optional integral Reacta-Control for integration with Reacta-Control wireless installations

### INSTALLATION

- Suitable for plasterboard installation
- Suitable for mineral fibre ceiling tile installation

### VARIATIONS

- Available with a wide range of colour temperatures and renderings
- Available in a range of lumen outputs
- Available with a range of collar colours

---

## IMAGES

---

### PRODUCT IMAGES



PTECD R WH



PTECD SSR WH



PTECD SSR WH + IP44



PTECD R WH OP



PTECD SSR WH ORA



PTECD R WH ORA



PTECD SSR WH BLE



PTECD R WH BLE



PTECD R GY + IP44



PTECD R GY DGR



PTECD R GY WH



PTECD R GY GRN



PTECD SSR GY BLE



PTECD R GY BLE



PTECD R BL



PTECD SSR BL

**PROJECT IMAGES**





TECHNICAL

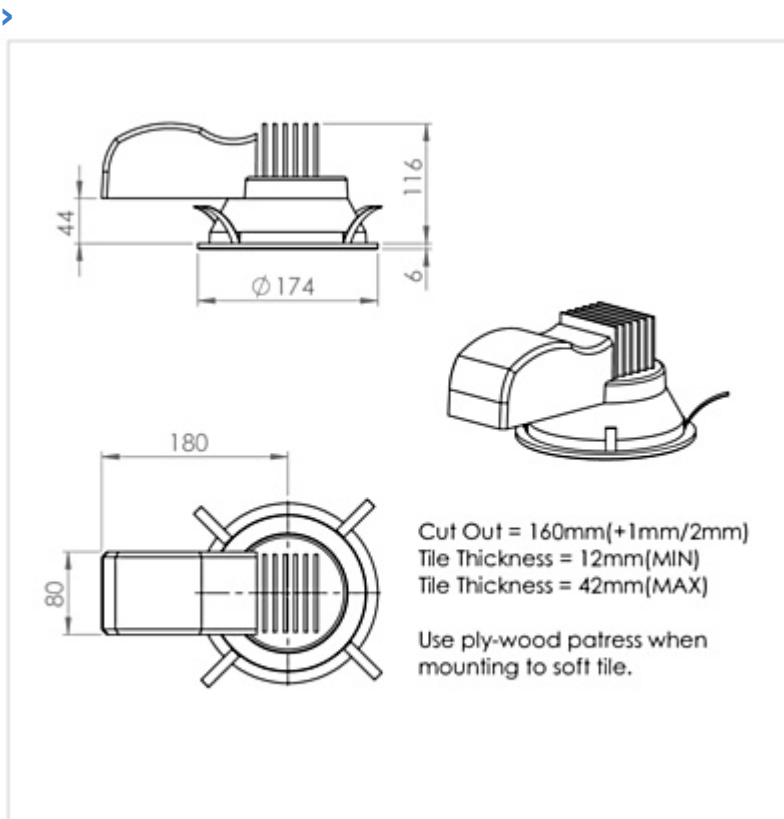

Protec

WARRANTY

At Dextra our commitment to service has been at the forefront throughout our history spanning more than forty years in the UK lighting market. Our service ethos extends beyond design and delivery, we believe supporting your installation

throughout the warranty period is equally crucial, whilst the strength and longevity of Dextra Group provides peace of mind that our warranty will be supported throughout.

The Dextra range is supplied with a five year warranty commencing from the date of delivery. During the first three years defects will be repaired on site and the warranty will include both parts and labour. For the final two years drivers, emergency modules, wireless modules, sensors and LED circuits will be supplied free of charge to replace defective components, labour and other associated costs are not included.

Certain ranges and components are subject to exemptions:

- Lithium batteries are provided with a five year warranty. During the first three years defects will be repaired on site and the warranty will include both parts and labour. For the final two years replacement batteries will be supplied free of charge to replace defective components. Five year warranty became effective as of 03/02/25, Lithium emergency luminaires supplied prior to this date are supported with a three year on site warranty only. Labour and other associated costs are not included. Nickel Metal Hydride and Nickel Cadmium batteries are provided with a one year warranty for parts and labour.
- Emergency luminaires including AME LED, EXI LED, EXI2 LED, EXI Track, HBE LED, HBE2 LED, OAT2 LED, OEZ LED and Twinspot with Nickel Metal Hydride batteries are supplied with a one year warranty for parts and labour. Lithium variants of these ranges are supplied with a three year warranty for parts and labour with the exception of the AME2, EXI3, HBE3 and TWS IP65 L7 ranges which are supplied with a one year parts and labour warranty. TWS IP65 L7 in autotest and wireless variants are supplied with the standard three year lithium battery warranty.
- Protec Micro, PTECF7 Fire Rated Downlights, Serenus and the Opus Sconce are provided with a five year replacement luminaire only warranty. Protec FR Fire Rated Downlights are provided with a 2 year replacement luminaire only warranty.
- Controls systems such as standalone sensors, switches, marshalling boxes and cabling are provided with a one year warranty for both parts and labour. DALI control systems are provided with a two year warranty for both parts and labour.
- LEDextra ranges are supplied with a three year parts or replacement luminaire only warranty with the exception of the IMPR RGBW, the Runway RBGW, the MOD RGBW, Tanek RGBW and the DexRing. These five ranges are supplied with our standard five year warranty during which defects within the first three years will be repaired on site and the warranty includes both parts and labour. For the final two years free of charge replacement components only will be supplied to rectify any failures but labour and other associated costs are not included.
- LEDEX ranges are supplied with a three year replacement luminaire only warranty.
- The Decorative Pendant ranges, Bebo, Dene, Nova, Fino and Stix are supplied with a 3 year replacement luminaire only warranty.

All warranties are subject to correct use of the product and will be invalidated by misuse, for example incorrect installation,



unsuitable environmental conditions or incorrect maintenance. It is the duty of the customer to ensure that all the fault lies with the luminaire prior to requesting replacement parts or site repairs. In the event that no defect is found with the product our costs for attending site will be recharged to the customer and credit will not be issued against returned products. No consequential losses incurred resulting from any defect with our product will be reimbursed.

Given the nature of LED technology a small percentage of LEDs may fail during the lifetime of a luminaire, this does not cause a reduction in lumen output. As such LED luminaires are only deemed to be faulty for warranty purposes when in excess of ten percent of LEDs have failed in a single luminaire.

On site repair of products under warranty will be undertaken during normal working hours, 9am to 5pm Monday to Friday, and will require unrestricted access to luminaires. Where required Dextra will provide access equipment to carry out repairs at height, should luminaires have been installed in locations where reasonable provision for maintenance access has not been made we reserve the right to supply replacement product only. On site warranty repairs will only be undertaken on the mainland of the UK and Ireland, in all other locations replacement product only will be provided.

**If you require any assistance with regards to our products please contact our Customer Services department on 01747 858100.**

## ORDER CODES

### LUMINAIRE

Code	Description	Power
PTECD L11	Protec, 1,100lm, Fixed Output, Colour 84	9.8W
PTECD L20	Protec, 2,000lm, Fixed Output, Colour 84	16.8W
PTECD L30	Protec, 3,000lm, Fixed Output, Colour 84	25.4W
PTECD L40	Protec, 4,000lm, Fixed Output, Colour 84	30.5W
PTECD L20 WT	Protec, 2,000lm, White Tunable, DT8, CRI90	17.9W
PTECD L30 WT	Protec, 3,000lm, White Tunable, DT8, CRI90	27.3W

Must be sold in conjunction with reflector listed below.

Protec Reflectors

Code	Description
PTECD R *	Specular Reflector, Without Halo
PTECD R * WHI	Specular Reflector, White Halo
PTECD R * GRE	Specular Reflector, Green Halo
PTECD R * BLE	Specular Reflector, Blue Halo
PTECD R * ORA	Specular Reflector, Mango Halo
PTECD R * OP	Specular Reflector, Opal Diffuser
PTECD R * MP	Specular Reflector, Microprism
PTECD R * DGR	Specular Reflector, Without Halo, Drop Glass Ring
PTECD SSR *	Semi-Specular Reflector, Without Halo
PTECD SSR * WHI	Semi-Specular Reflector, White Halo
PTECD SSR * GRE	Semi-Specular Reflector, Green Halo
PTECD SSR * BLE	Semi-Specular Reflector, Blue Halo
PTECD SSR * ORA	Semi-Specular Reflector, Mango Halo
PTECD SSR * OP	Semi-Specular Reflector, Opal Diffuser
PTECD SSR * MP	Semi-Specular Reflector, Microprism
PTECD SSR * DGR	Semi-Specular Reflector, Without Halo, Drop Glass Ring

Add suffix above in place of \* depending on bezel colour required

Bezel Colours

Code	Description
WH	White Bezel
GY	Grey Bezel
BL	Black Bezel

**DIMMING**

Code	Description
A	DALI Digital Addressable Lighting Interface
S	Switch Dimming
D	DSI Digital Dimming
H	HFR Analogue 1-10v
C	Bi-Level Dimming For Standalone Switched Sensor

Please click [here](#) for full details on our white tunable offer.

Analogue dimming only available in L18 variants

**CONTROL**

Code	Description
RLI	Reacta-Link, Wireless Enabled Luminaire
RC	Reacta-Control, Wireless Enabled Luminaire
RCSS	Reacta-Control Standalone Sensor, Presence & Daylight 2.5-4M, Use with RC Luminaires
RAD	Reacta-Air, Wireless Enabled Luminaire
RASS	Reacta-Air Standalone Sensor, Presence, 2.5-4M, Use with RAD Luminaires (sold separately)
RASSD	Reacta-Air Standalone Sensor, Presence & Daylight, 2.5-4M, Use with RAD Luminaires (sold separately)

\*Sensor supplied with luminaire for installation in adjacent ceiling tile. Only suitable for IP20 applications.

Please click [here](#) for full details on our wireless controls.

**EMERGENCY**

Code	Description
LE3	Lithium Standard Emergency 3 Hour
LS3	Lithium Selftest Emergency 3 Hour
LA3	Lithium Autotest Emergency 3 Hour

LSTR	Lithium Reacta-Link Emergency 3 Hour
LA3RC	Lithium Reacta-Control Emergency 3 Hour
CB	Central Battery, Please Specify 50V, 110V or 230V when Ordering

**MISCELLANEOUS**

Code	Description
C**	Select Colour Temperature and Rendering: C83, C84, C85, C865, C93, C94
4PM	4 Pole Panel Mount
6PM	6 Pole Panel Mount
INFILL	Infill Rings to Suit Over Size Ceiling Cut Out, Please Specify Size when Ordering.
LSF	Low Smoke Zero Halogen
PTECD IP44	IP44 Front Cover (IP44 from the front only, IP65 if silicone sealed)

## Protec Installation

220-240V / 50-60Hz  
IP20 / IP44 / IP65

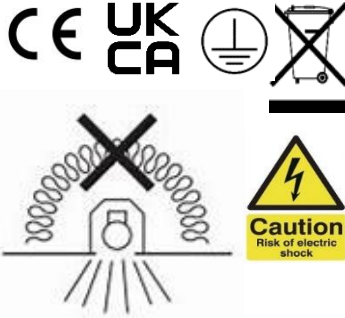

**WARNING:** Luminaire must be earthed. Risk of electric shock from LED boards if operated with cover removed. Installation / operation outside of luminaires intended scope invalidates warranty. Suitable only for domestic / light industrial / industrial applications within the scope of EN55015. Tested to compliance with BSEN 60598: specification for general requirements and tests. Must be installed by a suitably qualified person in accordance with all relevant legislation. Ambient operating temperature of 0°C to 25°C. If maximum operating temperature is exceeded luminaire will automatically dim / switch off. Terminal blocks are rated to 16A unless stated otherwise. The light source contained in this luminaire shall only be replaced by the manufacturer or his service agent or a similar qualified person.

**LUMINAIRES WITH EMERGENCY PACK:** When supply is isolated battery output terminals may be live if battery is connected. Isolate mains and battery before servicing. Emergency luminaires require unswitched live connection taken from same phase as switched supply. When unswitched supply is connected status indicator illuminates green, when unswitched supply is disconnected indicator extinguishes and luminaire operates in emergency mode. 24 hour charge period required before undertaking full discharge test. Emergency test sheets provided should be used to record all emergency tests. Batteries should be replaced when 3 hour duration is not met. Excessive switching of permanent live may result in premature battery failure. Battery electrolyte can be harmful to eyes / open wounds, do not puncture, if electrolyte touches skin / eyes flush with water. Do not incinerate batteries.

**Terminal Labelling:**

<b>Power</b>	
L1	Switched Live
E	Earth
N	Neutral
<b>Emergency</b>	
L2	Unswitched Live
DA/AT3	DALI Autotest
DA/AT3	DALI Autotest
<b>Dimming</b>	
-D1/DA	Analogue/DSI/DALI
+D2/DA	Analogue/DSI/DALI
L3	Switch Dim / Corridor Function

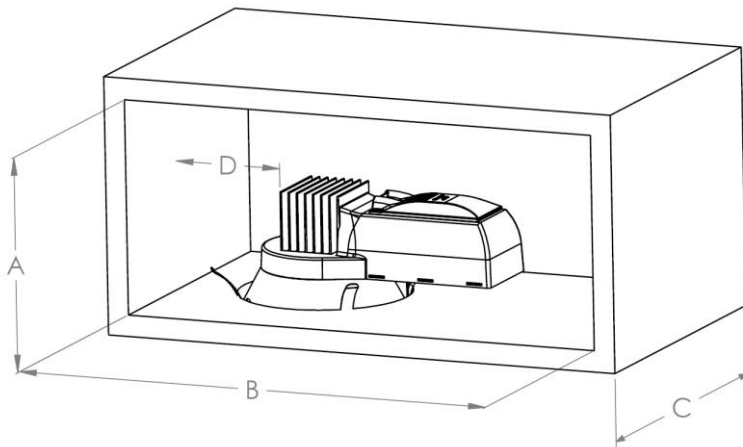
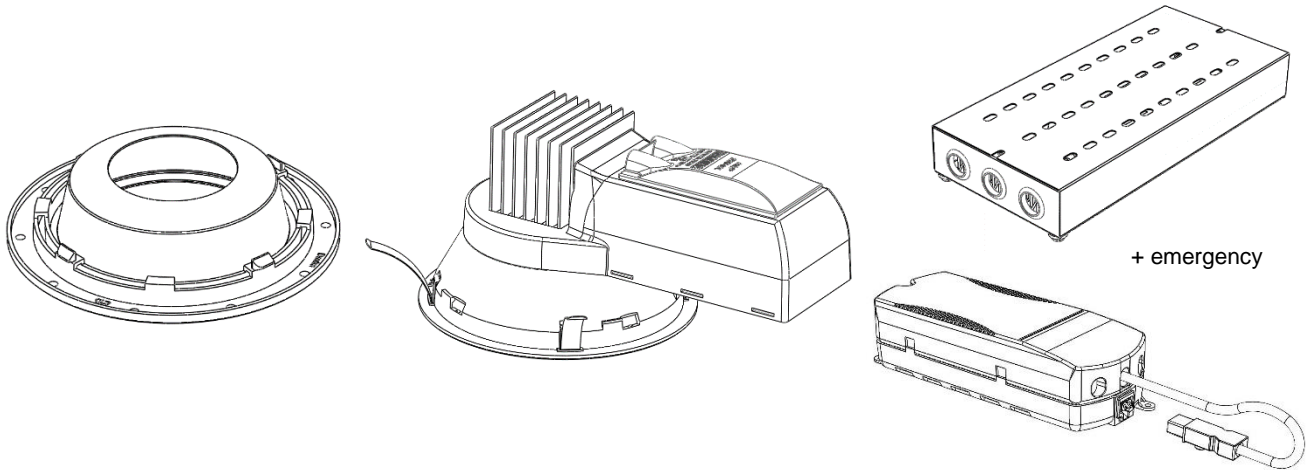

**Minimum Void Dimensions (mm)**

A = 260 (Emergency = 300)

B = 600

C = 270

D = 120

Ambient Temperature in the ceiling void = Min. -20° to Max. +35°

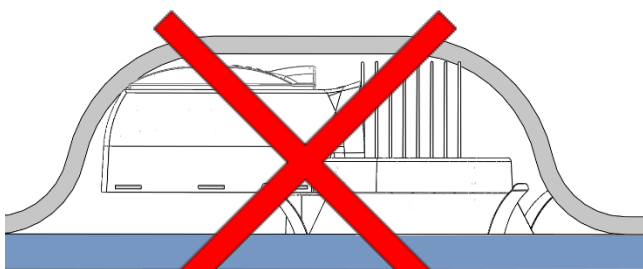

**DO NOT** cover heat sink

**NO INSULATION**

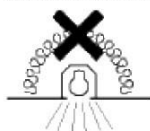

1. Hole aperture 160mm (Dia)

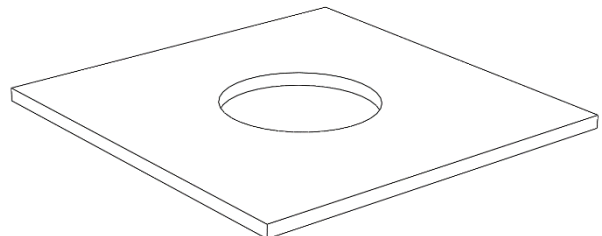

Use 3mm ply-wood patress when mounting to soft tile or ceiling depth less than 7mm.

Ceiling depth:  
Max. - 42mm  
Min. - 7mm

## Protec Installation

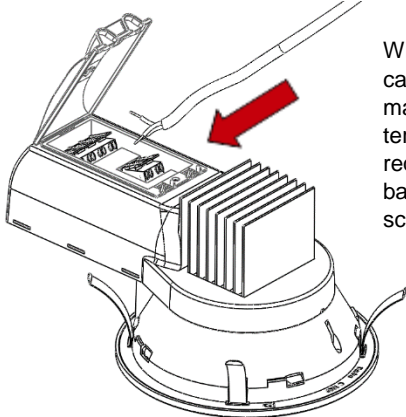
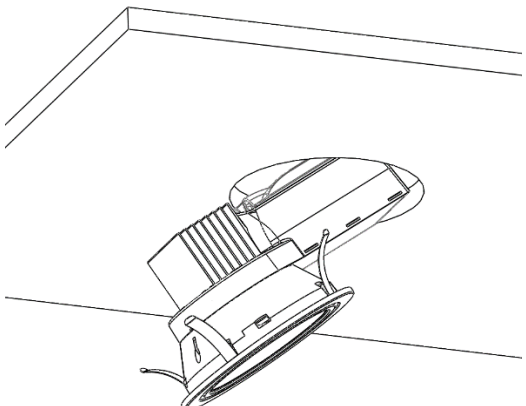
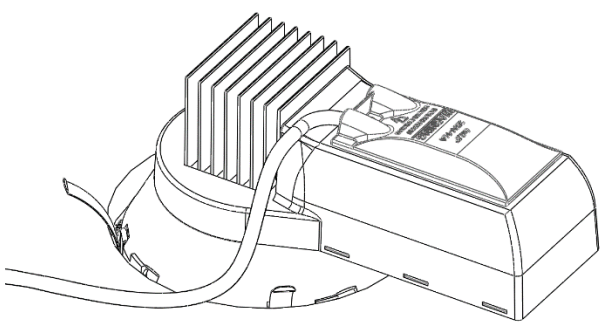
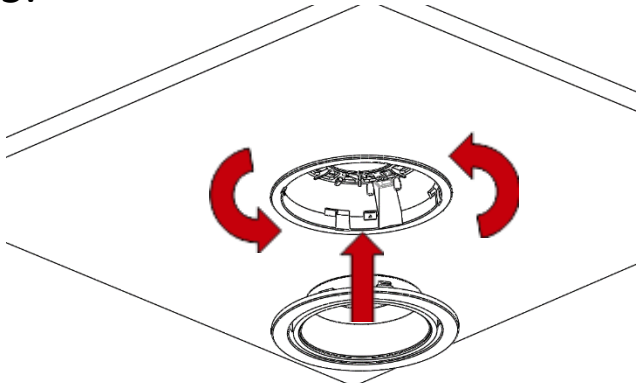
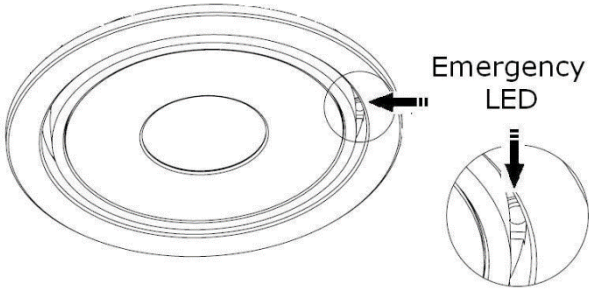
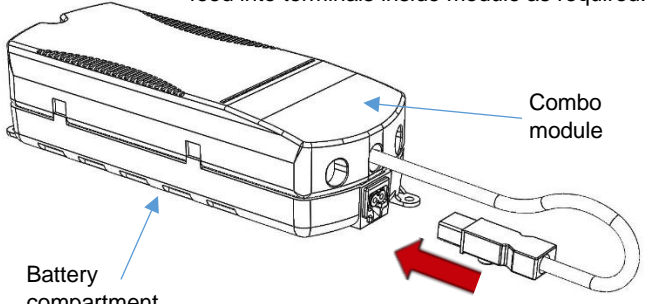
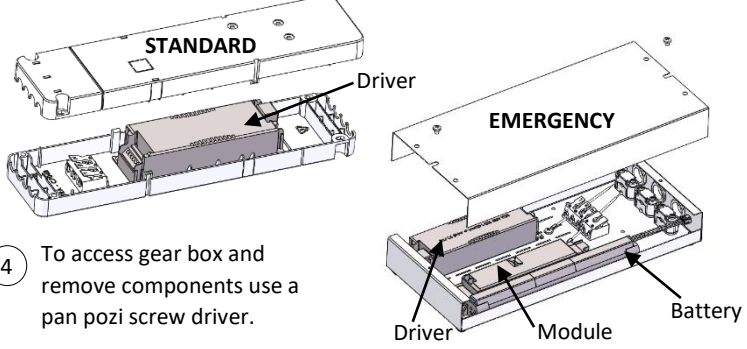
<p>2.</p>  <p>Wire mains cable into marked terminals as required. Close backflap and screw shut.</p>	<p>3.</p> 
<p>4.</p> 	<p>5.</p> 
<p>6.</p>  <p>Emergency LED</p>	<p>7.</p> <p>When Emergency combo module is used, battery must be connected by connecting the plug and socket shown below. Wire mains feed into terminals inside module as required.</p>  <p>Battery compartment</p> <p>Combo module</p>
<p><u>Maintenance</u></p> <ol style="list-style-type: none"> <li>1 Disconnect luminaire before undertaking any maintenance or cleaning.</li> <li>2 Cleaning should be undertaken on external parts of the luminaire only using a slightly damp lint free cloth.</li> <li>3 Please note that LED circuits are non-serviceable, replace fitting if needed.</li> <li>4 To access gear box and remove components use a pan pozi screw driver.</li> <li>5 Please contact Dextra for assistance with spare component supply.</li> </ol>  <p>STANDARD</p> <p>Driver</p> <p>EMERGENCY</p> <p>Driver</p> <p>Module</p> <p>Battery</p>	

# Generic Infill Ring Installation Guide

220-240V / 50-60Hz  
IP\*\*



Terminal Labelling:	
<b>Power</b>	
L1	Switched Live
E	Earth
N	Neutral
<b>Emergency</b>	
L2	Unswitched Live
DA/AT3	DALI Autotest
DA/AT3	DALI Autotest
<b>Dimming</b>	
-D1/DA	Analogue/DSI/DALI
+D2/DA	Analogue/DSI/DALI
L3	Switch Dim / Corridor Function

**WARNING:** Luminaire must be earthed. Risk of electric shock if operated with cover removed. Installation / operation outside of luminaires intended scope invalidates warranty. Suitable only for domestic / light industrial / industrial applications within the scope of EN55015. Tested to compliance with BSEN 60598: specification for general requirements and tests. Must be installed by a suitably qualified person in accordance with all relevant legislation. Ambient operating temperature of 0°C to 25°C. If maximum operating temperature is exceeded luminaire will automatically dim / switch off. Terminal blocks are rated to 16A unless stated otherwise. The light source is non replaceable. **LUMINAIRES WITH EMERGENCY PACK:** When supply is isolated battery output terminals may be live if battery is connected. Isolate mains and battery before servicing. Emergency luminaires require unswitched live connection taken from same phase as switched supply. When unswitched supply is connected status indicator illuminates green, when unswitched supply is disconnected indicator extinguishes and luminaire operates in emergency mode. 24 hour charge period required before undertaking full discharge test. Emergency test sheets provided should be used to record all emergency tests. Batteries should be replaced when 3 hour duration is not met. Excessive switching of permanent live may result in premature battery failure. Battery electrolyte can be harmful to eyes / open wounds, do not puncture, if electrolyte touches skin / eyes flush with water. Do not incinerate batteries.

1.

Attach the circular infill ring to the downlight.

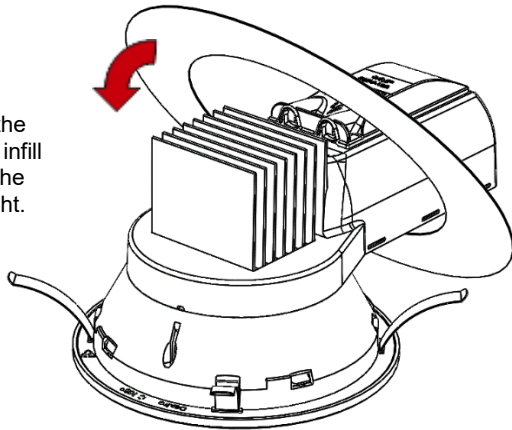

2.

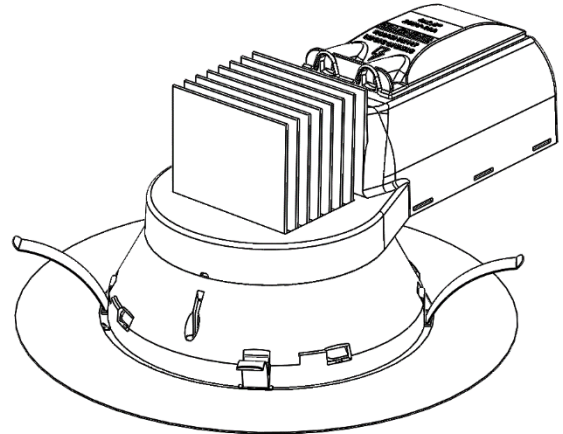

3.

Insert the oval infill ring through the aperture in the ceiling and let it rest on the ceiling. The oval infill ring should be narrow enough to fit through your ceiling aperture.

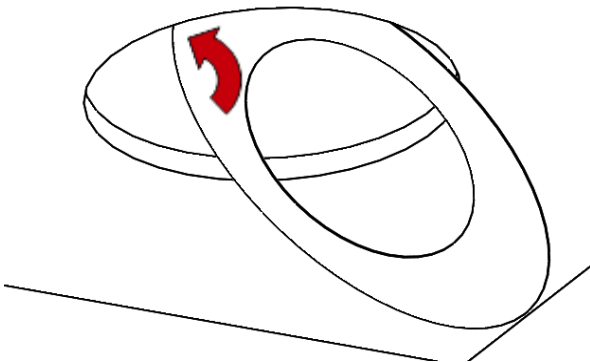

4.

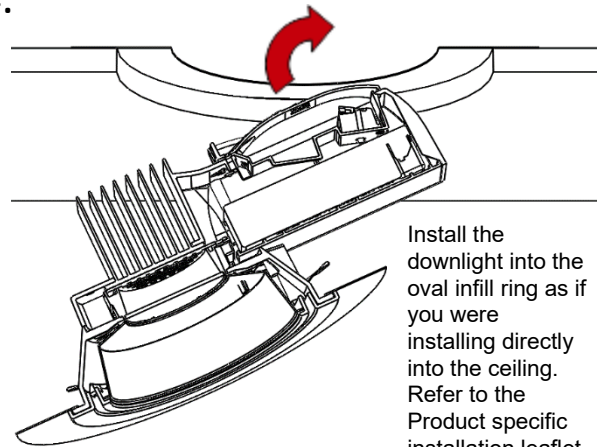

Install the downlight into the oval infill ring as if you were installing directly into the ceiling. Refer to the Product specific installation leaflet.

5.

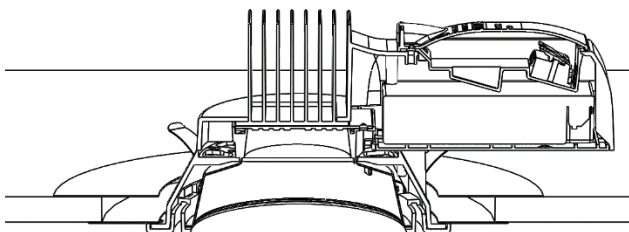

The downlight will need to be centralised in the ceiling aperture to ensure no gaps are visible.

6.