



PRODUCT SPECIFICATION

MOD OFFICE SURFACE



INTRODUCTION

The MOD Office Surface / Suspended has been designed specifically for applications where monitors are used in areas such as classrooms and offices.

By using a central microprism optic with high transmission opal surround the MOD Office Surface / Suspended is designed to comply with the latest BSEN 12464 glare requirements for both the 3000 candelas per metre squared limit above 65 degrees and UGR19 in most room sizes. Excellent optical control is combined with a wide range of lumen outputs ensuring that 400 lux average can be achieved with spacings as large as 3 metres by 3 metres. The MOD Office Surface / Suspended allows your installation to be designed with the minimum of luminaires, capital cost and energy consumption.

The MOD Office Surface / Suspended performance is combined with versatility with a range of options such as all common dimming variants white tunable, lithium emergency and a range of integral sensor options allowing you to further improve energy savings and return on investment. We offer a range of wireless control systems providing localised grouping and control as well as comprehensive wireless solutions allowing both standard and emergency luminaires to be centrally monitored.



CE IP40 TM21: L90>60K HOURS / L80>90K HOURS 3 STEP MACADAM ELLIPSE

APPLICATION

- Canteen
- Commercial / Offices
- Corridor

- Education
- Healthcare / Social Housing
- Hotel / Leisure
- Industrial / Manufacturing
- Office
- Retail
- Transport
- Warehouse / Storage

SPECIFICATION

CONSTRUCTION

- Housing: 0.7mm CR4 steel
- Finish: Polyester powder painted BS 00E55 matt white 60% gloss
- Diffuser: Combined 2mm high transmission opal polycarbonate TP(a) rated and 2mm microprism anti glare PMMA
- IK08
- IP40

PERFORMANCE

- Part L2 compliant
- BSEN 12464-1:2011 3000 Candela 65° and UGR 19 compliance
- 3SCDM Three step Macadams ellipse
- TM21: L90>60K Hours / L80>90K Hours
- Up to 121 luminaire lumens per circuit Watt.

ENVIRONMENTAL

- Designed to allow simple replacement of components with commonly available tools in compliance with the Eco Design Directive, please see the installation leaflet for maintenance instructions.
- All critical components are mounted on a single tray for simple end of life repair or upgrade.
- Powered by European branded drivers and emergency modules ensuring replacement parts are easily sourced.
- Every luminaire is labelled with a unique ID number allowing easy identification of spare parts for the lifetime of the product.
- Contains no single use plastics or polystyrene packaging.
- Supplied in plain card boxes with paper tape ensuring packaging is easily recycled.
- Designed to allow simple disassembly for end of life recycling.
- UK based manufacturing providing local support throughout the product lifetime and minimising transportation miles.

EMERGENCY

- Available with optional standard, self test and autotest integral emergency with lithium batteries for extended warranty and lifetime.
- Optional Reacta-Link wireless emergency for automated centralised reporting.

- Optional Reacta-Control wireless emergency for automated centralised reporting.
- Optional central battery changeover relay

CONTROL

- Optional compatibility with a range of dimming systems including DALI, DSI and Switch Dimming
- Optional White tunable
- Optional Integral Reacta-Air wireless presence and daylight regulations sensor
- Optional integral Reacta-Link for integration with Reacta-Link wireless installations
- Optional integral Reacta-Control for integration with Reacta-Control wireless installations

INSTALLATION

- Suitable for surface installation

VARIATIONS

- Available with a wide range of colour temperatures and renderings
- Available in a range of lumen outputs

IMAGES

PRODUCT IMAGES



MOD Office Surface 600x600



MOD Office Surface 600x600 with RAS

PROJECT IMAGES





TECHNICAL

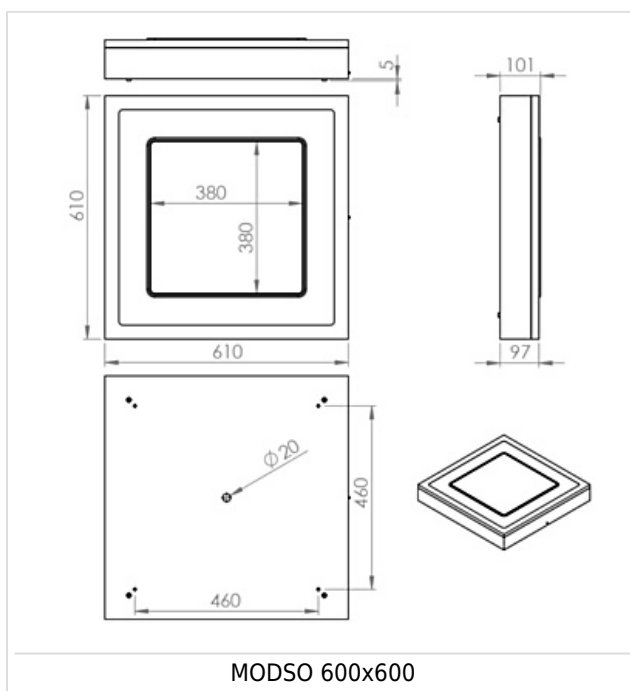

WARRANTY

At Dextra our commitment to service has been at the forefront throughout our history spanning more than forty years in the UK lighting market. Our service ethos extends beyond design and delivery, we believe supporting your installation throughout the warranty period is equally crucial, whilst the strength and longevity of Dextra Group provides peace of mind that our warranty will be supported throughout.

The Dextra range is supplied with a five year warranty commencing from the date of delivery. During the first three years defects will be repaired on site and the warranty will include both parts and labour. For the final two years drivers,

emergency modules, wireless modules, sensors and LED circuits will be supplied free of charge to replace defective components, labour and other associated costs are not included.

Certain ranges and components are subject to exemptions:

- Lithium batteries are provided with a three year warranty for parts and labour. Nickel Metal Hydride and Nickel Cadmium batteries are provided with a one year warranty for parts and labour.
- Emergency luminaires including AME LED, EXI LED, EXI2 LED, EXI Track, HBE LED, HBE2 LED, OAT2 LED, OEZ LED and Twinspot with Nickel Metal Hydride batteries are supplied with a one year warranty for parts and labour. Lithium variants of these ranges are supplied with a three year warranty for parts and labour with the exception of the AME2, EXI3, HBE3 and TWS IP65 L7 ranges which are supplied with a one year parts and labour warranty. TWS IP65 L7 in autotest and wireless variants are supplied with the standard three year lithium battery warranty.
- Protec Micro, PTECF7 Fire Rated Downlights, Serenus and the Opus Sconce are provided with a five year replacement luminaire only warranty. Protec FR Fire Rated Downlights are provided with a 2 year replacement luminaire only warranty.
- Controls systems such as standalone sensors, switches, marshalling boxes and cabling are provided with a one year warranty for both parts and labour. DALI control systems are provided with a two year warranty for both parts and labour.
- LEDextra ranges are supplied with a three year parts or replacement luminaire only warranty with the exception of the IMPR RGBW, the Runway RGBW, the MOD RGBW and the Tanek RGBW. These three ranges are supplied with our standard five year warranty during which defects within the first three years will be repaired on site and the warranty includes both parts and labour. For the final two years free of charge replacement components only will be supplied to rectify any failures but labour and other associated costs are not included.
- LEDEX ranges are supplied with a three year replacement luminaire only warranty.
- The Decorative Pendant ranges, Bebo, Dene, Nova, Fino and Stix are supplied with a 3 year replacement luminaire only warranty.

All warranties are subject to correct use of the product and will be invalidated by misuse, for example incorrect installation, unsuitable environmental conditions or incorrect maintenance. It is the duty of the customer to ensure that all the fault lies with the luminaire prior to requesting replacement parts or site repairs. In the event that no defect is found with the product our costs for attending site will be recharged to the customer and credit will not be issued against returned products. No consequential losses incurred resulting from any defect with our product will be reimbursed.

Given the nature of LED technology a small percentage of LEDs may fail during the lifetime of a luminaire, this does not cause a reduction in lumen output. As such LED luminaires are only deemed to be faulty for warranty purposes when in excess of ten percent of LEDs have failed in a single luminaire

On site repair of products under warranty will be undertaken during normal working hours, 9am to 5pm Monday to Friday, and will require unrestricted access to luminaires. Where required Dextra will provide access equipment to carry out repairs at height, should luminaires have been installed in locations where reasonable provision for maintenance access has not been made we reserve the right to supply replacement product only.

If you require any assistance with regards to our products please contact our Customer Services department on 01747 858100.

[DOWNLOAD WARRANTY PDF](#)

ORDER CODES

LUMINAIRE

Surface 600x600mm

Code	Description	Power	Llm/W
MODSO L25	MOD Office Surface/Suspended, 1,900lm, Colour 84	15.9W	119
MODSO L31	MOD Office Surface/Suspended, 2,297lm, Colour 84	20.1W	114
MODSO L37	MOD Office Surface/Suspended, 2,767lm, Colour 84	24.4W	113
*MODSO L45	MOD Office Surface/Suspended, 3,328lm, Colour 84	27.4W	121
*MODSO L50	MOD Office Surface/Suspended, 3,711lm, Colour 84	30.9W	120

C83 option available on special request with specific lumen outputs.

*May not offer UGR19 compliance in some room sizes.

DIMMING

Code	Description
A	DALI Digital Addressable Lighting Interface
S	Switch Dimming
D	DSI Digital Dimming
H	HFR Analogue 1-10v
C	Bi-Level Dimming For Standalone Switched Sensor
WT	White Tunable (Lumen Outputs Vary from Standard)

Please click [here](#) for full details on our white tunable offer.

CONTROL

Code	Description
RAS	Reacta-Air Bluetooth, Wireless, Presence & Daylight, 2.5-3M
RLI	Reacta-Link, Wireless Enabled Luminaire
RLS	Reacta-Link Wireless, Presence, 2.5-4M
RC	Reacta-Control, Wireless Enabled Luminaire
RCS	Reacta-Control Wireless, Presence, Daylight, 2.5-4M

Please click [here](#) for full details on our wireless controls.

Please note, that we are able to offer absence detection sensors on request, please contact our Sales Department for more details.

Please contact our Sales Department for advice on compatible connecting cables.

EMERGENCY

Code	Description
LE3	Lithium Standard Emergency 3 Hour
LS3	Lithium Selftest Emergency 3 Hour
LA3	Lithium Autotest Emergency 3 Hour
LSTR	Lithium Reacta-Link Emergency 3 Hour
LA3RC	Lithium Reacta-Control Emergency 3 Hour
CB	Central Battery, Please Specify 50V, 110V or 230V when Ordering

MISCELLANEOUS

Code	Description
C**	Select Colour Temperature and Rendering; C83, C84, C85, C865, C93, C94
SUSP 4 POINT 3M BF X4	Four Point Suspension Kit
LSF	Low Smoke Zero Halogen