



PRODUCT SPECIFICATION

LED4 WIRELESS



INTRODUCTION

The LED4 Wireless incorporates lithium batteries for extended warranty and lifetime compared to traditional Ni-Cad and Ni-Mh battery chemistries. Designed to complement mains operated luminaires, the LED4 Wireless is a standalone non maintained emergency luminaire and includes compatibility with our Reacta-Link and Reacta-Control wireless system enabling automated emergency testing and centralised reporting of test results and failures substantially reducing emergency test costs and simplifying battery maintenance. All luminaires are supplied complete with a range of easily changed lenses for open area, escape route and spot applications ensuring that a single luminaire can be installed across any project and the lenses changed as and when required to provide the necessary light distribution.

**UK
CA** CE IP20

APPLICATION

- Canteen
- Commercial / Offices
- Corridor
- Education
- Food / Clean Area
- Healthcare / Social Housing
- Hotel / Leisure
- Industrial / Manufacturing

- Kitchen
- Office
- Retail
- Stairwell
- Store Room
- Toilet
- Transport
- Warehouse / Storage

SPECIFICATION

CONSTRUCTION

- Housing: Injection moulded polycarbonate
- Finish: Matt black
- Finish: Matt white
- Lens: Injection moulded PMMA lens
- IP20

ENVIRONMENTAL

- Every luminaire is labelled with a unique ID number allowing easy identification of spare parts for the lifetime of the product.
- UK based manufacturing providing local support throughout the product lifetime and minimising transportation miles.

EMERGENCY

- Optional Reacta-Control wireless emergency for automated centralised reporting.

INSTALLATION

- Suitable for plasterboard installation
- Suitable for mineral fibre ceiling tile installation

VARIATIONS

- Available in white or black finishes
- Supplied with three lens variants, open area, escape route and spot

IMAGES

PRODUCT IMAGES



LED4 Wireless



LED4 Wireless Remote Pack



LED4 Wireless White



LED4 Wireless Black

TECHNICAL

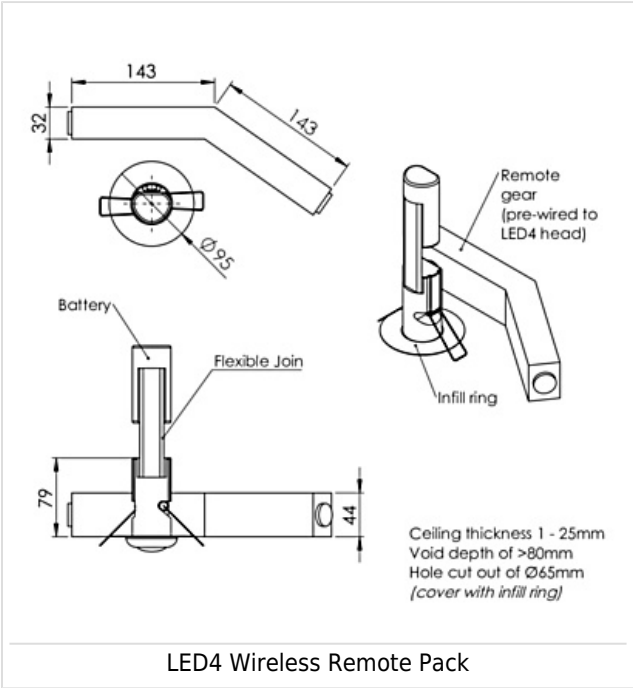

LED4 Wireless Remote Pack

WARRANTY

At Dextra our commitment to service has been at the forefront throughout our history spanning more than forty years in the UK lighting market. Our service ethos extends beyond design and delivery, we believe supporting your installation throughout the warranty period is equally crucial, whilst the strength and longevity of Dextra Group provides peace of mind that our warranty will be supported throughout.

The Dextra range is supplied with a five year warranty commencing from the date of delivery. During the first three years defects will be repaired on site and the warranty will include both parts and labour. For the final two years drivers, emergency modules, wireless modules, sensors and LED circuits will be supplied free of charge to replace defective components, labour and other associated costs are not included.

Certain ranges and components are subject to exemptions:

- Lithium batteries are provided with a three year warranty for parts and labour. Nickel Metal Hydride and Nickel Cadmium batteries are provided with a one year warranty for parts and labour.
- Emergency luminaires including AME LED, EXI LED, EXI2 LED, EXI Track, HBE LED, HBE2 LED, OAT2 LED, OEZ LED and Twinspot with Nickel Metal Hydride batteries are supplied with a one year warranty for parts and labour. Lithium variants of these ranges are supplied with a three year warranty for parts and labour with the exception of the AME2, EXI3, HBE3 and TWS IP65 L7 ranges which are supplied with a one year parts and labour warranty. TWS IP65 L7 in autotest and wireless variants are supplied with the standard three year lithium battery warranty.
- Protec Micro, PTECF7 Fire Rated Downlights, Serenus and the Opus Sconce are provided with a five year replacement luminaire only warranty. Protec FR Fire Rated Downlights are provided with a 2 year replacement luminaire only warranty.
- Controls systems such as standalone sensors, switches, marshalling boxes and cabling are provided with a one year warranty for both parts and labour. DALI control systems are provided with a two year warranty for both parts and labour.
- LEDextra ranges are supplied with a three year parts or replacement luminaire only warranty with the exception of the IMPR RGBW, the Runway RGBW, the MOD RGBW and the Tanek RGBW. These three ranges are supplied with our standard five year warranty during which defects within the first three years will be repaired on site and the warranty includes both parts and labour. For the final two years free of charge replacement components only will be supplied to rectify any failures but labour and other associated costs are not included.
- LEDEX ranges are supplied with a three year replacement luminaire only warranty.
- The Decorative Pendant ranges, Bebo, Dene, Nova, Fino and Stix are supplied with a 3 year replacement luminaire only warranty.

All warranties are subject to correct use of the product and will be invalidated by misuse, for example incorrect installation, unsuitable environmental conditions or incorrect maintenance. It is the duty of the customer to ensure that all the fault lies with the luminaire prior to requesting replacement parts or site repairs. In the event that no defect is found with the product our costs for attending site will be recharged to the customer and credit will not be issued against returned products. No consequential losses incurred resulting from any defect with our product will be reimbursed.

Given the nature of LED technology a small percentage of LEDs may fail during the lifetime of a luminaire, this does not cause a reduction in lumen output. As such LED luminaires are only deemed to be faulty for warranty purposes when in excess of ten percent of LEDs have failed in a single luminaire

On site repair of products under warranty will be undertaken during normal working hours, 9am to 5pm Monday to Friday, and will require unrestricted access to luminaires. Where required Dextra will provide access equipment to carry out repairs at height, should luminaires have been installed in locations where reasonable provision for maintenance access has not been made we reserve the right to supply replacement product only.

If you require any assistance with regards to our products please contact our Customer Services department on 01747 858100.

[DOWNLOAD WARRANTY PDF](#)

ORDER CODES

LUMINAIRE

Code	Description	Power
LED4R NM3 LA3RC	LED4 Wireless, Lithium Non Maintained, Reacta-Control Emergency 3 Hour, 217lm	2.0W
LED4R NM3 LS3R	LED4 Wireless, Lithium Non-Maintained, Reacta-Link Emergency 3 Hour, 217lm	2.0W

Lumen outputs based on Open Area lens

MISCELLANEOUS

Code	Description
BL	Black Finish
