

PRODUCT SPECIFICATION

GLIDE IN-GROUND



INTRODUCTION

The Glide In-Ground provides a discreet wall grazing solution for both internal and external applications. Manufactured with a toughened glass diffuser and stainless steel frame the Glide In-Ground is designed for walk over applications with a 3.5 tonne weight limit and an IK08 impact rating. An IP66 construction and internally potted electronics ensures the Glide In-Ground is designed to withstand all weather conditions and temperatures ranging from -20°C to +40°C.

This robust design combines with a wide range of colour temperatures, luminaire lengths, lumen outputs and 20×20° wall grazing lensed optics ensuring that the Glide In-Ground can be tailored to suit a wide range of applications. RGBW variants are available where decorative effects need to be achieved to create attractive exterior spaces and to highlight architectural features.

**UK
CA** CE IP66 IK08 230V

APPLICATION

- ▶ Façade Lighting
- ▶ Hotel / Leisure
- ▶ Parking / Exterior
- ▶ Retail

- › Shop Front
-

SPECIFICATION

CONSTRUCTION

- › Housing: Extruded aluminium
- › IK08
- › IP66 housing and electrical connectors
- › Stainless steel cover
- › Step tempered glass
- › 3.5 tonne weight limit
- › Clear glass diffuser with brushed steel frame
- › Working temperatures -20 to +40°C

ENVIRONMENTAL

- › Designed to allow simple replacement of components with commonly available tools in compliance with the Eco Design Directive, please see the installation leaflet for maintenance instructions.
- › Powered by European branded drivers and emergency modules ensuring replacement parts are easily sourced.
- › Every luminaire is labelled with a unique ID number allowing easy identification of spare parts for the lifetime of the product.
- › Contains no single use plastics or polystyrene packaging.
- › Supplied in plain card boxes with paper tape ensuring packaging is easily recycled.
- › Designed to allow simple disassembly for end of life recycling.
- › UK based manufacturing providing local support throughout the product lifetime and minimising transportation miles.

PERFORMANCE

- › 24W power for 505mm / 48W for 930mm
- › 20x20° beam angle
- › Other beam angles available on request
- › 50,000 operating hours

INSTALLATION

- › Available with separately supplied in ground housing for ease of installation
- › Available with power and control cables

IMAGES

PRODUCT IMAGES



Glide In-Ground 930mm



Glide In-Ground 930mm with recessing housing



Glide In-Ground 930mm recessing housing



Glide In-Ground Installation

PROJECT IMAGES





TECHNICAL

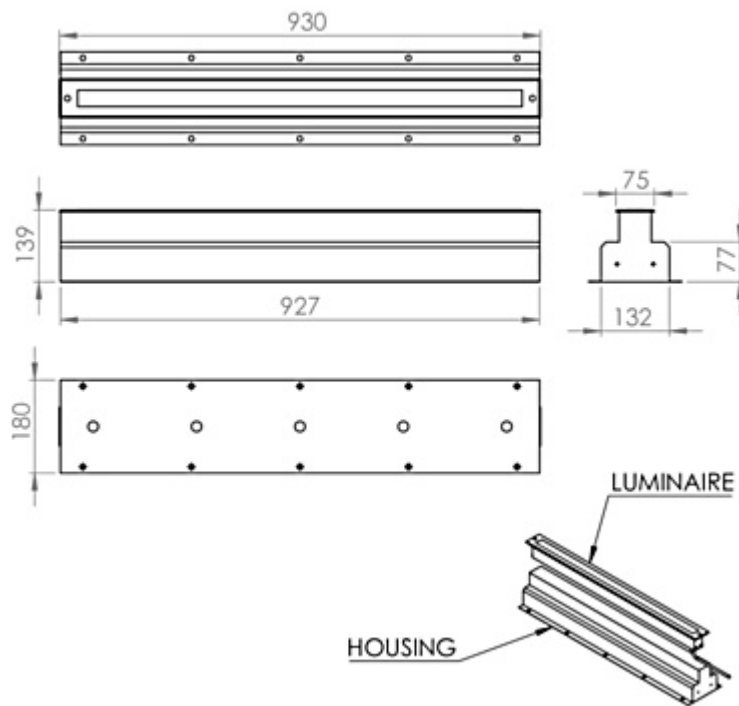

Glide In-Ground 930mm



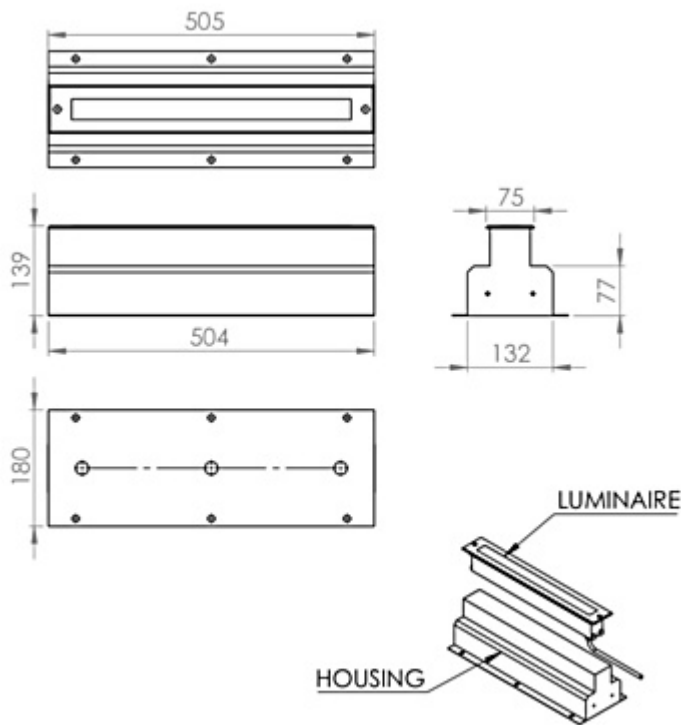

Glide in-Ground 500mm

WARRANTY

At Dextra our commitment to service has been at the forefront throughout our history spanning more than forty years in the UK lighting market. Our service ethos extends beyond design and delivery, we believe supporting your installation throughout the warranty period is equally crucial, whilst the strength and longevity of Dextra Group provides peace of mind that our warranty will be supported throughout.

The Dextra range is supplied with a five year warranty commencing from the date of delivery. During the first three years defects will be repaired on site and the warranty will include both parts and labour. For the final two years drivers, emergency modules, wireless modules, sensors and LED circuits will be supplied free of charge to replace defective components, labour and other associated costs are not included.

Certain ranges and components are subject to exemptions:

- Lithium batteries are provided with a five year warranty. During the first three years defects will be repaired on site and the warranty will include both parts and labour. For the final two years replacement batteries will be supplied free of charge to replace defective components. Five year warranty became effective as of 03/02/25, Lithium emergency luminaires supplied prior to this date are supported with a three year on site warranty only. Labour and other associated costs are not included. Nickel Metal Hydride and Nickel Cadmium batteries are provided with a one year warranty for parts and labour.

- Emergency luminaires including AME LED, EXI LED, EXI2 LED, EXI Track, HBE LED, HBE2 LED, OAT2 LED, OEZ LED and Twinspot with Nickel Metal Hydride batteries are supplied with a one year warranty for parts and labour. Lithium variants of these ranges are supplied with a three year warranty for parts and labour with the exception of the AME2, EXI3, HBE3 and TWS IP65 L7 ranges which are supplied with a one year parts and labour warranty. TWS IP65 L7 in autotest and wireless variants are supplied with the standard three year lithium battery warranty.
- Protec Micro, PTECF7 Fire Rated Downlights, Serenus and the Opus Sconce are provided with a five year replacement luminaire only warranty. Protec FR Fire Rated Downlights are provided with a 2 year replacement luminaire only warranty.
- Controls systems such as standalone sensors, switches, marshalling boxes and cabling are provided with a one year warranty for both parts and labour. DALI control systems are provided with a two year warranty for both parts and labour.
- LEDextra ranges are supplied with a three year parts or replacement luminaire only warranty with the exception of the IMPR RGBW, the Runway RGBW, the MOD RGBW, Tanek RGBW and the DexRing. These five ranges are supplied with our standard five year warranty during which defects within the first three years will be repaired on site and the warranty includes both parts and labour. For the final two years free of charge replacement components only will be supplied to rectify any failures but labour and other associated costs are not included.
- LEDEX ranges are supplied with a three year replacement luminaire only warranty.
- The Decorative Pendant ranges, Bebo, Dene, Nova, Fino and Stix are supplied with a 3 year replacement luminaire only warranty.

All warranties are subject to correct use of the product and will be invalidated by misuse, for example incorrect installation, unsuitable environmental conditions or incorrect maintenance. It is the duty of the customer to ensure that all the fault lies with the luminaire prior to requesting replacement parts or site repairs. In the event that no defect is found with the product our costs for attending site will be recharged to the customer and credit will not be issued against returned products. No consequential losses incurred resulting from any defect with our product will be reimbursed.

Given the nature of LED technology a small percentage of LEDs may fail during the lifetime of a luminaire, this does not cause a reduction in lumen output. As such LED luminaires are only deemed to be faulty for warranty purposes when in excess of ten percent of LEDs have failed in a single luminaire.

On site repair of products under warranty will be undertaken during normal working hours, 9am to 5pm Monday to Friday, and will require unrestricted access to luminaires. Where required Dextra will provide access equipment to carry out repairs at height, should luminaires have been installed in locations where reasonable provision for maintenance access has not been made we reserve the right to supply replacement product only. On site warranty repairs will only be undertaken on the mainland of the UK and Ireland, in all other locations replacement product only will be provided.

If you require any assistance with regards to our products please contact our Customer Services department on 01747 858100.

ORDER CODES

LUMINAIRE

Code	Description	Power	Llm/W
GIG L24 2020 C83	Glide In-Ground, 505mm, 20x20°, IP66, Colour 83	24.0W	
GIG L24 2020 C84	Glide In-Ground, 505mm, 20x20°, IP66, Colour 84	24.0W	
GIG L48 2020 C83	Glide In-Ground, 930mm, 3,765lm, 20x20°, IP66, Colour 83	49.3W	76
GIG L48 2020 C84	Glide In-Ground, 930mm, 4,029lm, 20x20°, IP66, Colour 84	49.3W	82

Also available in RGBW, please contact LEDextra for more info

MISCELLANEOUS

Code	Description
GIG HOUSING 500MM	Glide In-Ground Housing 500mm
GIG HOUSING 1000MM	Glide In-Ground Housing 1000mm

IP66
IK08



Terminal Labelling:	
Power	
L1	Switched Live
E	Earth
N	Neutral
Emergency	
L2	Unswitched Live
DA/AT3	DALI Autotest
DA/AT3	DALI Autotest
Dimming	
-/D1/DA	Analogue/DSI/DALI
+/D2/DA	Analogue/DSI/DALI
L3	Switch Dim / Corridor Function

WARNING: Luminaire must be earthed. Risk of electric shock from LED boards if operated with cover removed. Installation / operation outside of luminaires intended scope invalidates warranty. Suitable only for domestic / light industrial / industrial applications within the scope of EN55015. Tested to compliance with BSEN 60598: specification for general requirements and tests. Must be installed by a suitably qualified person in accordance with all relevant legislation. Ambient operating temperature of 0°C to 25°C. If maximum operating temperature is exceeded luminaire will automatically dim / switch off. Terminal blocks are rated to 16A unless stated otherwise. The light source is non replaceable. **LUMINAIRES WITH EMERGENCY PACK:** When supply is isolated battery output terminals may be live if battery is connected. Isolate mains and battery before servicing. Emergency luminaires require unswitched live connection taken from same phase as switched supply. When unswitched supply is connected status indicator illuminates green, when unswitched supply is disconnected indicator extinguishes and luminaire operates in emergency mode. 24 hour charge period required before undertaking full discharge test. Emergency test sheets provided should be used to record all emergency tests. Batteries should be replaced when 3 hour duration is not met. Excessive switching of permanent live may result in premature battery failure. Battery electrolyte can be harmful to eyes / open wounds, do not puncture, if electrolyte touches skin / eyes flush with water. Do not incinerate batteries.

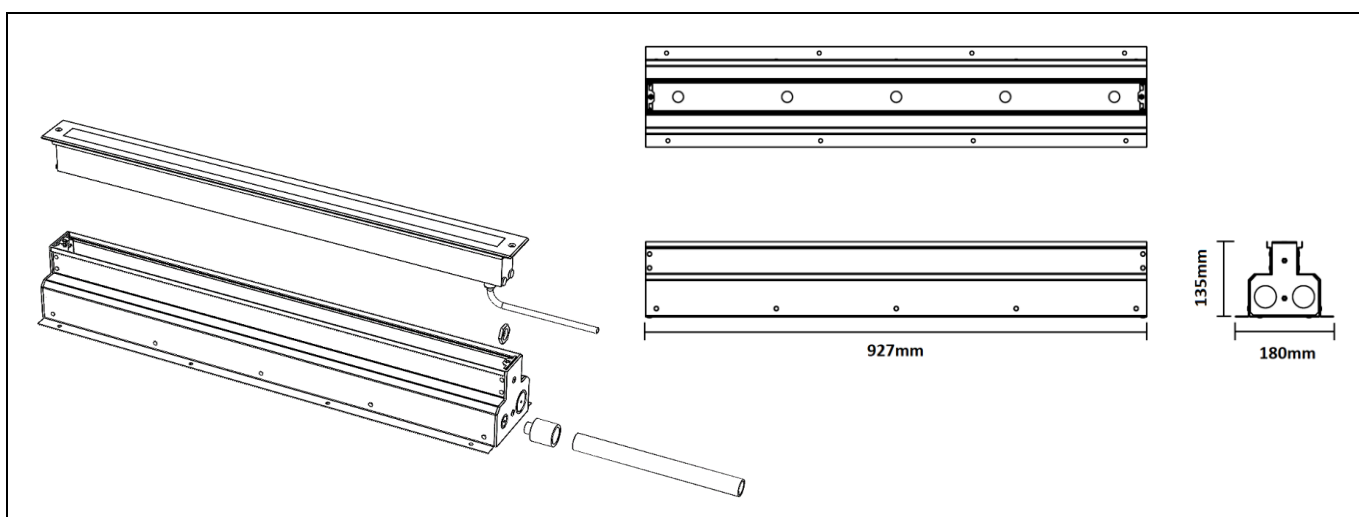

1. Prepare Ground

Soft Ground

- Proper drainage material must support the entire mounting box length in order for it to reach 1000kg resistance.
- If drainage material is used, provide support for the entire mounting box length and install adequate drainage piping.

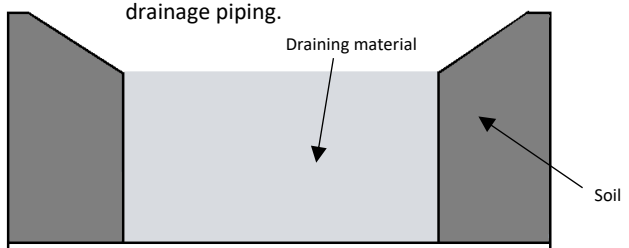

Hard Ground

- Prepare ground hole, including proper drainage piping. The length of the entire mounting box must be supported in order to reach 1000kg resistance.

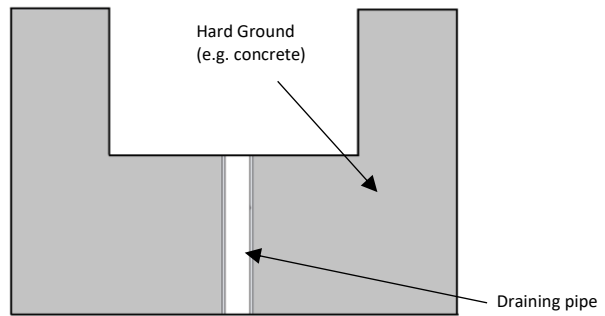

2. Test Drainage

Testing the Drainage Piping

- In order to validate the efficiency of the drainage piping, a quantity of water equivalent to the volume of the mounting box must completely drain in 30 minutes.
- Drainage testing should be performed prior to installation of the In-ground luminaire.

Soft Ground

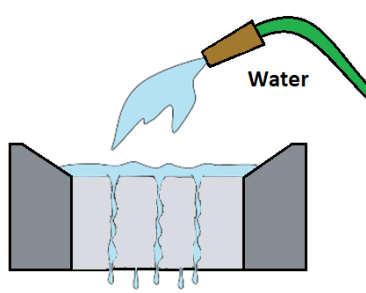

Hard Ground

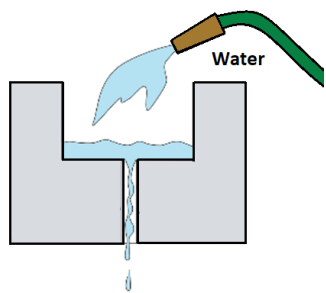

Mounting Box Length = 1m (927mm)
 Mounting Box Volume = 12,713cm³ (776in³)
 Minimum drainage rate = 0.43L/ min (0.11gal./ min)

WARNING: Failure to provide adequate draining installation will void warranty.

Glide In-Ground (GIG) Installation

3. Install Conduits and Cables

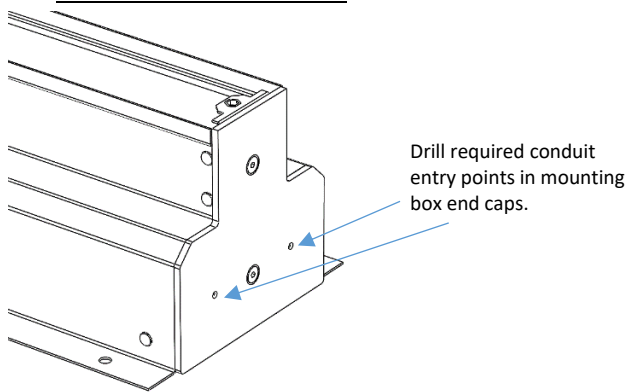

4.

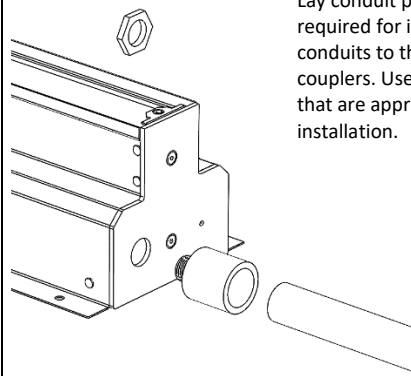

5. Level Mounting Box

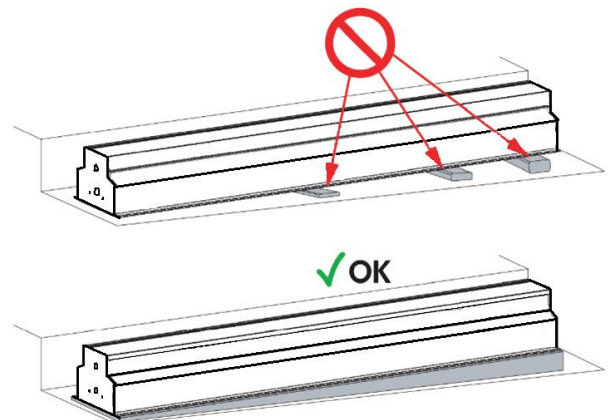
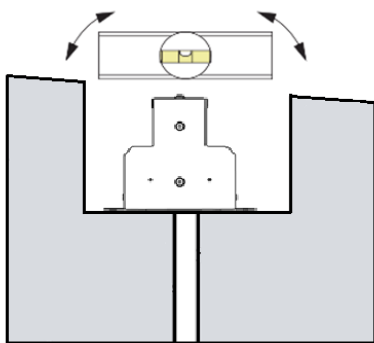

6.

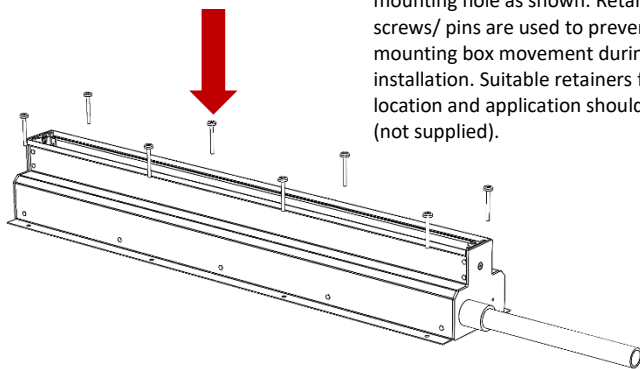

Soft Ground

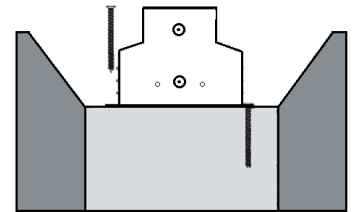

Hard Ground

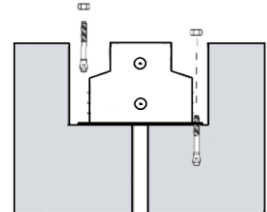

7. Install mounting box cover

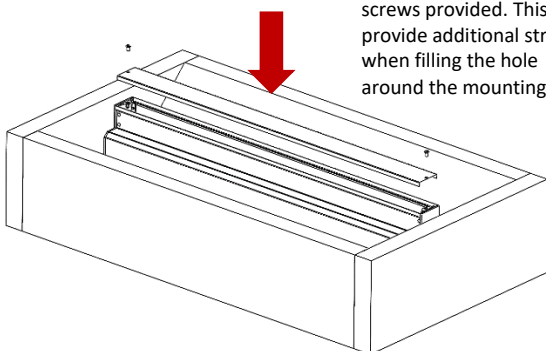

8.

Perform a final inspection before pouring filling material. Ensure the mounting box is level and does not move. Failure to ensure the box is secure may result in a failed installation and will void the warranty.

Glide In-Ground (GIG) Installation

9.

- Pour the material (concrete) around the mounting box.
- It is critical to ensure the material is flush with the top of the mounting box!
- Clean the top of the mounting box to remove any excess of material that may prevent cover removal.

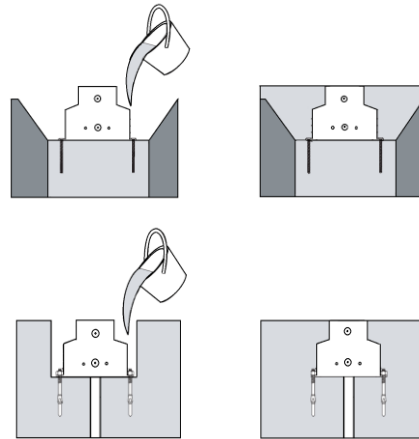

10.

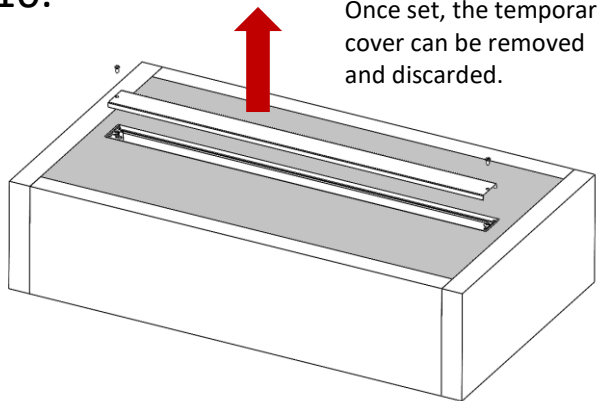

Once set, the temporary cover can be removed and discarded.

11.

The mounting box is walk-over compliant up to 1000kg, concrete supported. A minimum of 10" (0.25m) of concrete is required around the entire length and height of the mounting box.

12. Installation Guidelines



Valid Installations
1000kg walk-over compliant,
concrete-supported

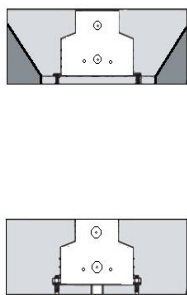

Concrete must support 100% of the mounting box's exterior surfaces in order to comply with 1000kg walk-over resistance requirements.



Valid Installations
500kg walk-over compliant,
self-supported

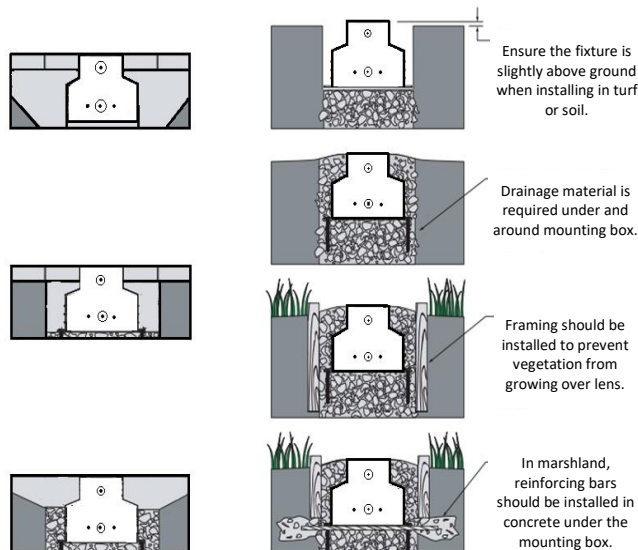

Incorrect Installations

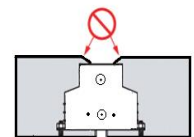

Mounting box must never be installed below ground level.

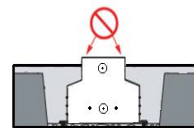

Mounting box must never protrude from ground level.

Glide In-Ground (GIG) Installation

13. Luminaire Installation

Feed the electrical cable through the conduit or make the relevant electrical connections to incoming cabling outside of the mounting box. Once electrical cabling connections have been made, tuck the cable inside the box.

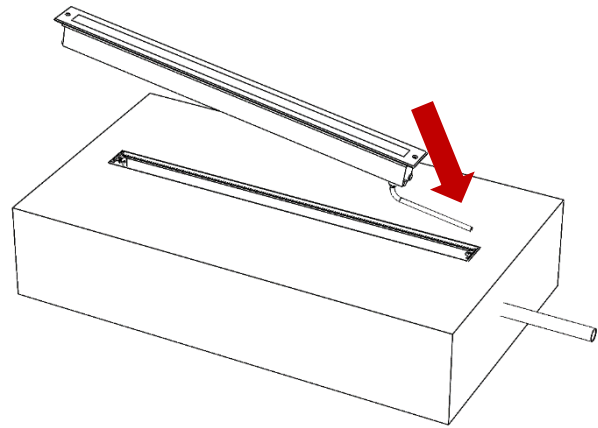

14.

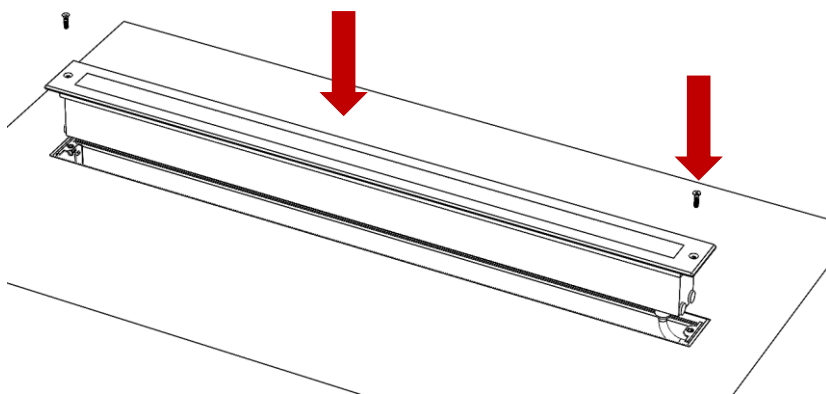

- Carefully fit the luminaire into the mounting box, ensuring the cabling does not get trapped.
- Fix in position using the 2x M5 screws provided and ensure fitting trim sits flush with the ground.