

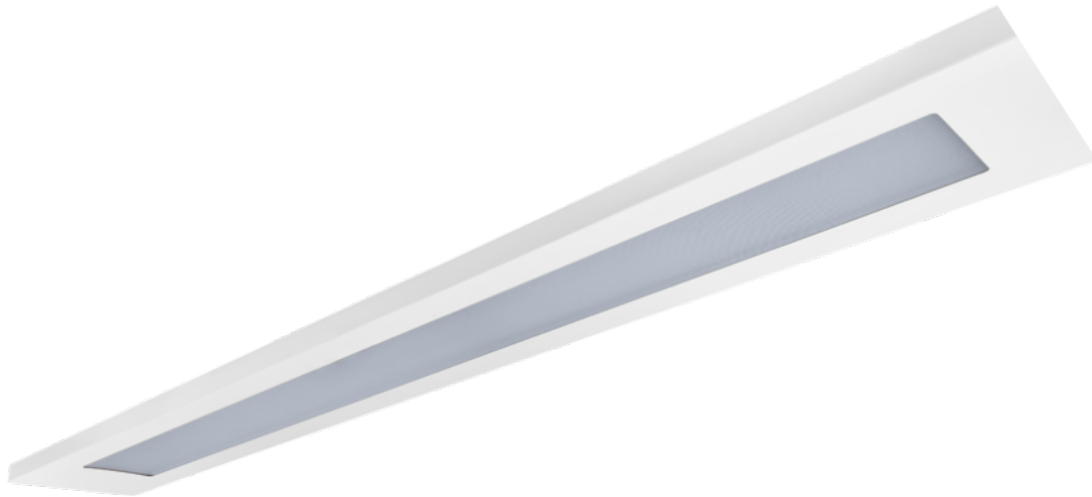

PRODUCT SPECIFICATION

ELEMENT SUSPENDED



INTRODUCTION

The Element Suspended is suitable for suspended installation with bi directional output, 40% up, 60% down. This versatility is combined with a shallow body profile and glare compliant diffuser providing a sleek appearance and compliance with the glare regulations of BSEN 12464 for use in offices and schools.

The versatility of the Element is further enhanced with a wide range of lumen packages, optional integral sensors, wireless controls and all common dimming and lithium emergency variants.

We offer a range of wireless control systems providing localised grouping and control as well as comprehensive wireless solutions allowing both standard and emergency luminaires to be centrally monitored.

UK
CA CE IP20 TM21: L90>60K HOURS / L80>90K HOURS 3 STEP MACADAM ELLIPSE

APPLICATION

- Commercial / Offices
- Education
- Office

SPECIFICATION

CONSTRUCTION

- Housing: 0.7mm CR4 steel
- Finish: Polyester powder painted BS 00E55 matt white 60% gloss
- Finish: Polyester powder painted RAL 9006 matt grey
- Finish: Polyester powder painted RAL 9005 matt black
- Diffuser: Combined 2mm high transmission opal polycarbonate TP(a) rated and 2mm microprism anti glare PMMA
- IP20

PERFORMANCE

- Part L2 compliant
- BSEN 12464-1:2011 3000 Candela 65° and UGR 19 compliance
- 3SCDM Three step Macadams ellipse
- TM21: L90>60K Hours / L80>90K Hours
- Bi-Directional 40% up 60% down
- Up to 148 luminaire lumens per circuit Watt.

ENVIRONMENTAL

- Designed to allow simple replacement of components with commonly available tools in compliance with the Eco Design Directive, please see the installation leaflet for maintenance instructions.
- Powered by European branded drivers and emergency modules ensuring replacement parts are easily sourced.
- Every luminaire is labelled with a unique ID number allowing easy identification of spare parts for the lifetime of the product.
- Contains no single use plastics or polystyrene packaging.
- Supplied in plain card boxes with paper tape ensuring packaging is easily recycled.
- Designed to allow simple disassembly for end of life recycling.
- UK based manufacturing providing local support throughout the product lifetime and minimising transportation miles.

EMERGENCY

- Available with optional standard, self test and autotest integral emergency with lithium batteries for extended warranty and lifetime.
- Optional Reacta-Link wireless emergency for automated centralised reporting.
- Optional Reacta-Control wireless emergency for automated centralised reporting.
- Optional central battery changeover relay

CONTROL

- Optional Integral R44 presence and daylight sensor
- Optional Integral Reacta-Air wireless presence and daylight regulations sensor
- Optional integral Reacta-Link for integration with Reacta-Link wireless installations
- Optional integral Reacta-Control for integration with Reacta-Control wireless installations

INSTALLATION

- Suitable for suspended installation
- Suitable for two point suspension
- Please note bi-directional variants use two drivers.

VARIATIONS

- Available with a wide range of colour temperatures and renderings
- Available in a range of housing sizes and lumen outputs
- Available in white, black or grey finishes

IMAGES

PRODUCT IMAGES

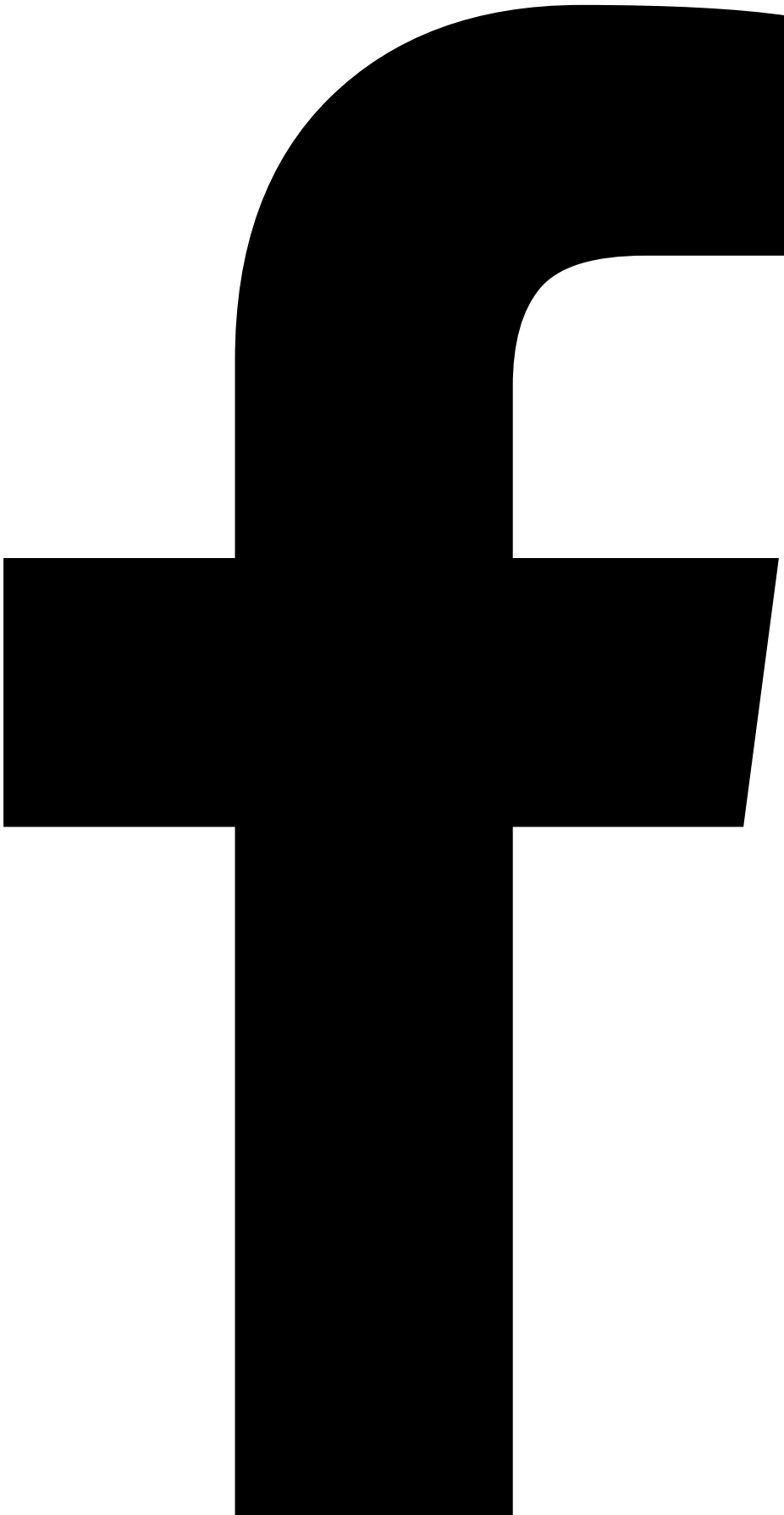

Element Suspended

PROJECT IMAGES



TECHNICAL

ELEMENT DESIGN CONSIDERATIONS

- Standalone versions supplied complete with 3M suspension kit.
- Suspension kits sold separately for continuous run versions.
- Autotest LA3 emergency and DALI Dimming will use common DALI BUS Cable. LA3 emergency can not be combined with other dimming types.
- Bi-Directional versions provide 60% down light and 40% up light.
- Bi-Directional variants use two drivers and therefore DALI variants require two addresses.
- Integral sensors are only available in the luminaire, one required per luminaire.
- 1200mm variants can not accommodate both integral emergency and integral sensor.

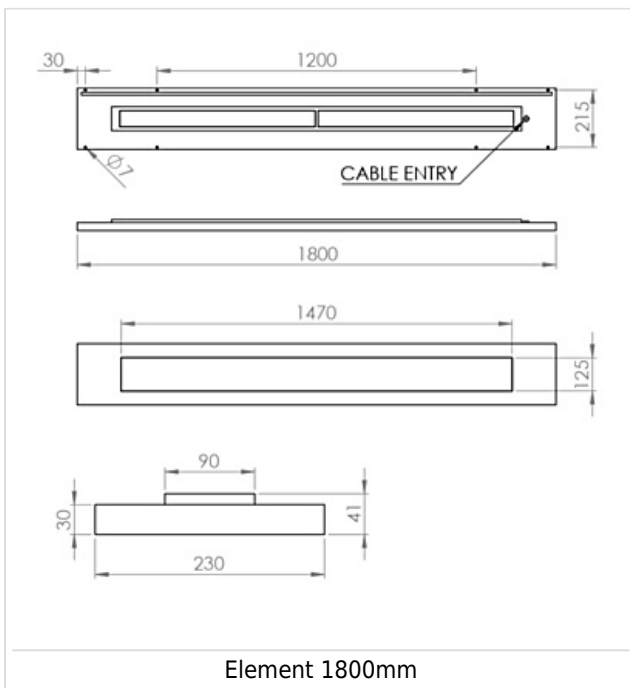
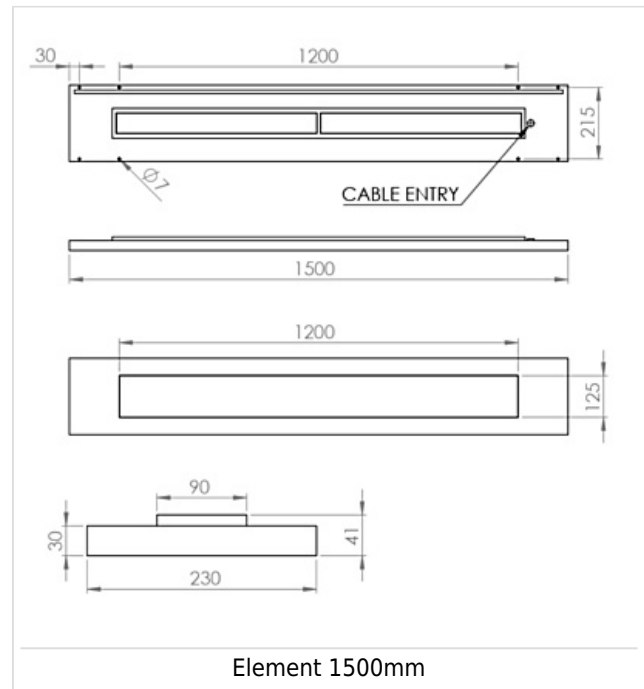
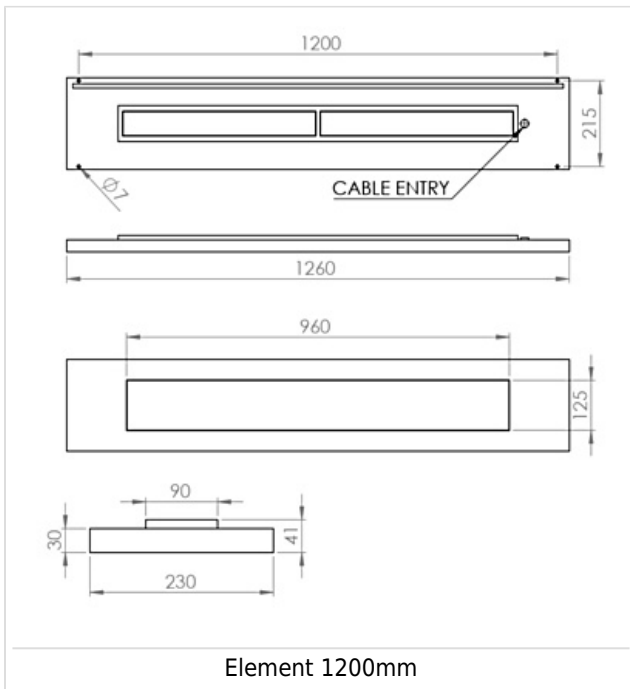

WARRANTY

At Dextra our commitment to service has been at the forefront throughout our history spanning more than forty years in the UK lighting market. Our service ethos extends beyond design and delivery, we believe supporting your installation throughout the warranty period is equally crucial, whilst the strength and longevity of Dextra Group provides peace of mind that our warranty will be supported throughout.

The Dextra range is supplied with a five year warranty commencing from the date of delivery. During the first three years

defects will be repaired on site and the warranty will include both parts and labour. For the final two years drivers, emergency modules, wireless modules, sensors and LED circuits will be supplied free of charge to replace defective components, labour and other associated costs are not included.

Certain ranges and components are subject to exemptions:

- Lithium batteries are provided with a three year warranty for parts and labour. Nickel Metal Hydride and Nickel Cadmium batteries are provided with a one year warranty for parts and labour.
- Emergency luminaires including AME LED, EXI LED, EXI2 LED, EXI Track, HBE LED, HBE2 LED, OAT2 LED, OEZ LED and Twinspot with Nickel Metal Hydride batteries are supplied with a one year warranty for parts and labour. Lithium variants of these ranges are supplied with a three year warranty for parts and labour with the exception of the AME2, EXI3, HBE3 and TWS IP65 L7 ranges which are supplied with a one year parts and labour warranty. TWS IP65 L7 in autotest and wireless variants are supplied with the standard three year lithium battery warranty.
- Protec Micro, PTECF7 Fire Rated Downlights, Serenus and the Opus Sconce are provided with a five year replacement luminaire only warranty. Protec FR Fire Rated Downlights are provided with a 2 year replacement luminaire only warranty.
- Controls systems such as standalone sensors, switches, marshalling boxes and cabling are provided with a one year warranty for both parts and labour. DALI control systems are provided with a two year warranty for both parts and labour.
- LEDextra ranges are supplied with a three year parts or replacement luminaire only warranty with the exception of the IMPR RGBW, the Runway RGBW, the MOD RGBW and the Tanek RGBW. These three ranges are supplied with our standard five year warranty during which defects within the first three years will be repaired on site and the warranty includes both parts and labour. For the final two years free of charge replacement components only will be supplied to rectify any failures but labour and other associated costs are not included.
- LEDEX ranges are supplied with a three year replacement luminaire only warranty.
- The Decorative Pendant ranges, Bebo, Dene, Nova, Fino and Stix are supplied with a 3 year replacement luminaire only warranty.

All warranties are subject to correct use of the product and will be invalidated by misuse, for example incorrect installation, unsuitable environmental conditions or incorrect maintenance. It is the duty of the customer to ensure that all the fault lies with the luminaire prior to requesting replacement parts or site repairs. In the event that no defect is found with the product our costs for attending site will be recharged to the customer and credit will not be issued against returned products. No consequential losses incurred resulting from any defect with our product will be reimbursed.

Given the nature of LED technology a small percentage of LEDs may fail during the lifetime of a luminaire, this does not cause a reduction in lumen output. As such LED luminaires are only deemed to be faulty for warranty purposes when in excess of ten percent of LEDs have failed in a single luminaire

On site repair of products under warranty will be undertaken during normal working hours, 9am to 5pm Monday to Friday, and will require unrestricted access to luminaires. Where required Dextra will provide access equipment to carry out repairs at height, should luminaires have been installed in locations where reasonable provision for maintenance access has not been made we reserve the right to supply replacement product only.

If you require any assistance with regards to our products please contact our Customer Services department on 01747 858100.

[DOWNLOAD WARRANTY PDF](#)

ORDER CODES

LUMINAIRE

Element Suspended Standalone

Downlight

Code	Description	Power	Llm/W
ELL 12L20	Element, 1260mm, 1,508llm, Microprism, Colour 84	12.8W	118
ELL 12L30	Element, 1260mm, 2,262llm, Microprism, Colour 84	20.3W	111
ELL 12L40	Element, 1260mm, 3,016llm, Microprism, Colour 84	24.5W	123
ELL 15L37	Element, 1500mm, 2,901llm, Microprism, Colour 84	24.7W	118
ELL 15L50	Element, 1500mm, 3,920llm, Microprism, Colour 84	27.2W	144
ELL 15L60	Element, 1500mm, 4,704llm, Microprism, Colour 84	32.8W	143
ELL 18L45	Element, 1800mm, 3,488llm, Microprism, Colour 84	27.5W	126
ELL 18L60	Element, 1800mm, 4,650llm, Microprism, Colour 84	33.4W	139
ELL 18L75	Element, 1800mm, 5,813llm, Microprism, Colour 84	41.0W	142

Bi-Directional

Code	Description	Power	Llm/W
ELLBD 12L30	Element, 1260mm, 2,435llm, Microprism, Bi-Directional, Colour 84	21.2W	115
ELLBD 12L40	Element, 1260mm, 3,247llm, Microprism, Bi-Directional, Colour 84	26.3W	123
ELLBD 12L50	Element, 1260mm, 4,059llm, Microprism, Bi-Directional, Colour 84	31.3W	130
ELLBD 15L50	Element, 1500mm, 4,162llm, Microprism, Bi-Directional, Colour 84	31.4W	132
ELLBD 15L60	Element, 1500mm, 4,994llm, Microprism, Bi-Directional, Colour 84	37.7W	132
ELLBD 15L68	Element, 1500mm, 5,660llm, Microprism, Bi-Directional, Colour 84	42.8W	132
ELLBD 18L60	Element, 1800mm, 4,985llm, Microprism, Bi-Directional, Colour 84	36.4W	136
ELLBD 18L75	Element, 1800mm, 6,231llm, Microprism, Bi-Directional, Colour 84	42.2W	148
ELLBD 18L90	Element, 1800mm, 7,477llm, Microprism, Bi-Directional, Colour 84	50.9W	147

DIMMING

Code	Description
A	DALI Digital Addressable Lighting Interface

Please refer to the Element Design Consideration notes in the Technical section prior to placing your order.

CONTROL

Code	Description
R44	Reacta 44, Presence & Daylight, 2.5-7M
RAS	Reacta-Air Bluetooth, Wireless, Presence & Daylight, 2.5-3M
RLI	Reacta-Link, Wireless Enabled Luminaire
RLS	Reacta-Link Wireless, Presence, 2.5-4M
RC	Reacta-Control, Wireless Enabled Luminaire
RCS	Reacta-Control Wireless, Presence, Daylight, 2.5-4M

Please click [here](#) for full details on our wireless controls.

Please refer to the Element Design Consideration notes in the Technical section prior to placing your order.

EMERGENCY

Code	Description
LE3	Lithium Standard Emergency 3 Hour
LS3	Lithium Selftest Emergency 3 Hour

LA3	Lithium Autotest Emergency 3 Hour
LSTR	Lithium Reacta-Link Emergency 3 Hour
LA3RC	Lithium Reacta-Control Emergency 3 Hour

Please refer to the Element Design Consideration notes in the Technical section prior to placing your order.

MISCELLANEOUS

Code	Description
C**	Select Colour Temperature and Rendering; C83, C84, C85, C865, C93, C94
BL	Black Finish
GY	Grey Finish
SUSP RBX SIR ELL 3M BF X2	3M Suspension Kit
LSF	Low Smoke Zero Halogen