



# PRODUCT SPECIFICATION

---

## ECOPAK LENS SENSOR



---

## INTRODUCTION

---

The Ecopak Lens is a versatile LED batten available in two sizes and a wide range of lumen outputs. The lensed optic provides premium energy efficiency with three lens types suited to applications including open area, high rack and ultra high rack. This flexibility is further enhanced with a wide range of dimming control gear and integral lithium emergency options. We offer a range of wireless control systems providing localised grouping and control as well as comprehensive wireless solutions allowing both standard and emergency luminaires to be centrally monitored.

Quick and simple installation is key to the success of the Ecopak with a two part construction allowing the housing to be installed before the one piece gear tray and lens assembly is connected using quick release spring clips. With drivers rated to 100,000 hour lifetime, LEDs rated to L90 at 60,000 operating hours and excellent energy efficiency the Ecopak provides a long lasting solution with low lifetime operating costs. The Ecopak Sensor is available with a range of sensors offering presence detection, daylight regulation and remote control programming enabling further energy savings and carbon reductions to be realised.



CE IP20 TM21: L90>60K HOURS / L80>90K HOURS 3 STEP MACADAM ELLIPSE

---

## APPLICATION

---

- Commercial / Offices
- Corridor
- Education
- Healthcare / Social Housing

- Hotel / Leisure
- Industrial / Manufacturing
- Retail
- Stairwell
- Store Room
- Transport
- Warehouse / Storage

---

## SPECIFICATION

---

### CONSTRUCTION

- Housing: 0.6mm CR4 steel
- Finish: Polyester powder painted BS 00E55 matt white 60% gloss
- Lens: Injection moulded polycarbonate lens
- IP20

### PERFORMANCE

- Part L2 compliant
- 3SCDM Three step Macadams ellipse
- TM21: L90>60K Hours / L80>90K Hours
- Up to XXX luminaire lumens per circuit Watt

### ENVIRONMENTAL

- Designed to allow simple replacement of components with commonly available tools in compliance with the Eco Design Directive, please see the installation leaflet for maintenance instructions.
- Powered by European branded drivers and emergency modules ensuring replacement parts are easily sourced.
- Every luminaire is labelled with a unique ID number allowing easy identification of spare parts for the lifetime of the product.
- Contains no single use plastics or polystyrene packaging.
- Supplied in plain card boxes with paper tape ensuring packaging is easily recycled.
- Designed to allow simple disassembly for end of life recycling.
- UK based manufacturing providing local support throughout the product lifetime and minimising transportation miles.

### EMERGENCY

- Available with optional standard, self test and autotest integral emergency with lithium batteries for extended warranty and lifetime.
- Optional Reacta-Link wireless emergency for automated centralised reporting.
- Optional Reacta-Control wireless emergency for automated centralised reporting.

### CONTROL

- Optional compatibility with a range of dimming systems including DALI, DSI and Switch Dimming

- Optional Integral R21 presence sensor
- Optional Integral R44 presence and daylight sensor
- Optional Integral Reacta-Air wireless presence and daylight regulations sensor
- Optional integral Reacta-Link for integration with Reacta-Link wireless installations
- Optional integral Reacta-Control for integration with Reacta-Control wireless installations
- Ground level commissioning with REA-AP controller allows quick and simple setting and adjustment of sensors without the need for costly commissioning.

### INSTALLATION

- Suitable for suspended installation
- Suitable for trunking installation
- Suitable for conduit installation
- Suitable for surface installation

### VARIATIONS

- Available with a wide range of colour temperatures and renderings
- Available in a range of housing sizes and lumen outputs

---

## IMAGES

---

### PRODUCT IMAGES

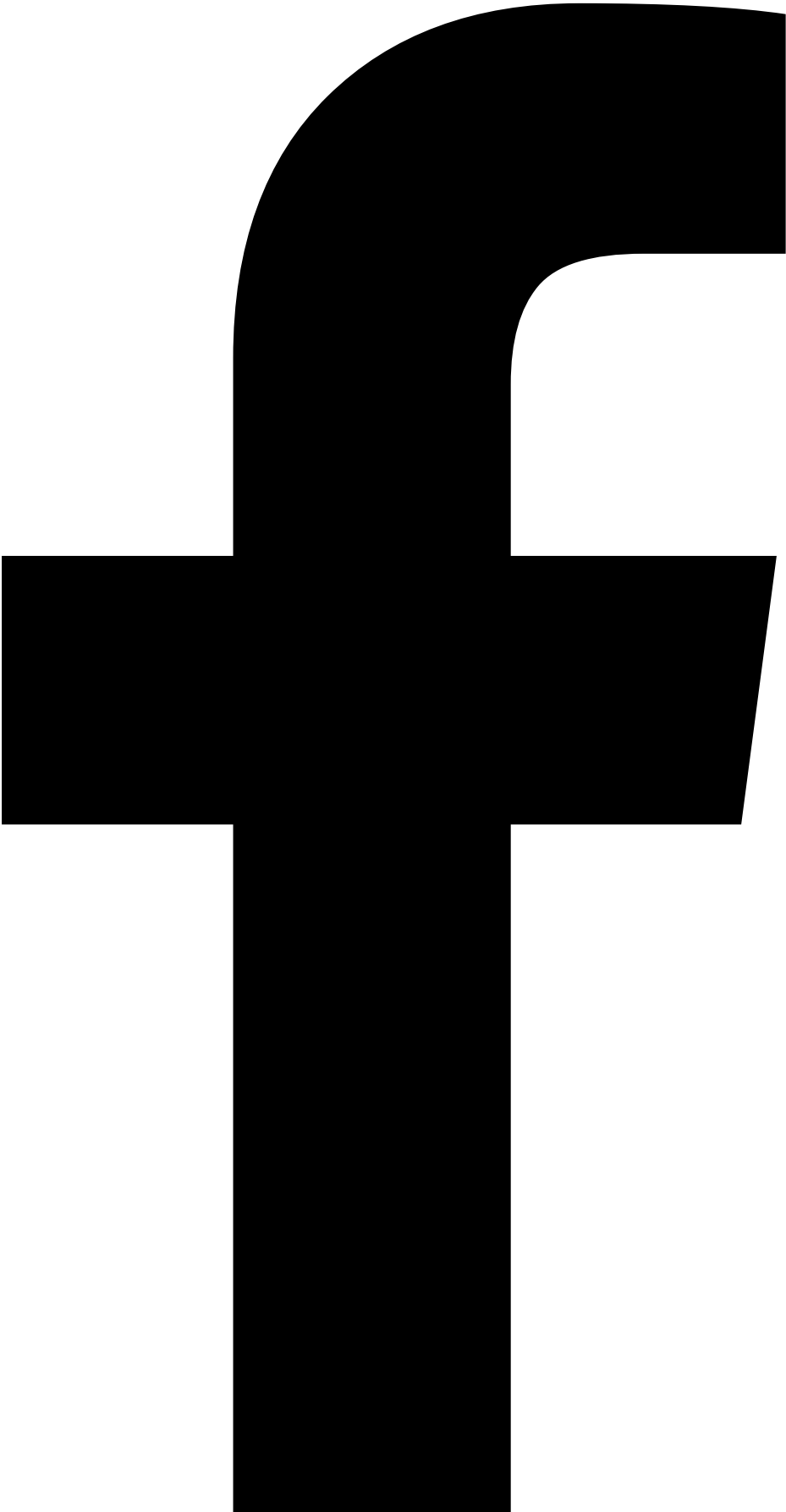

EPK Lens Sensor

## TECHNICAL

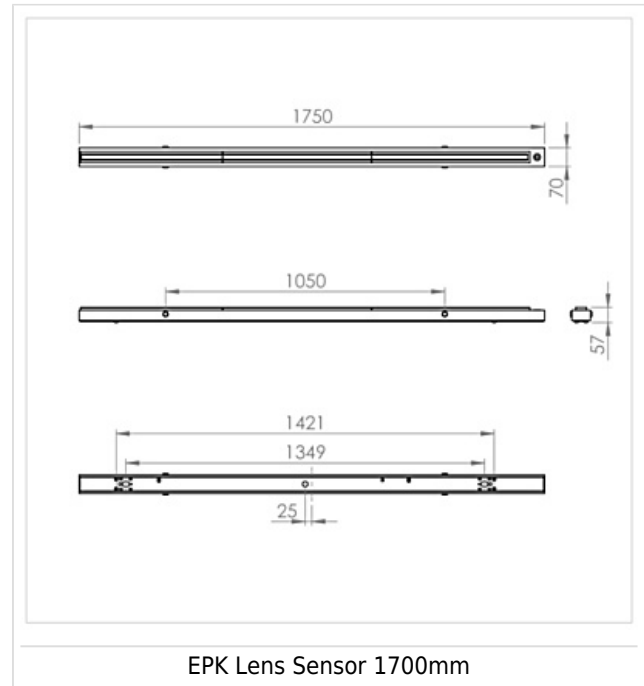
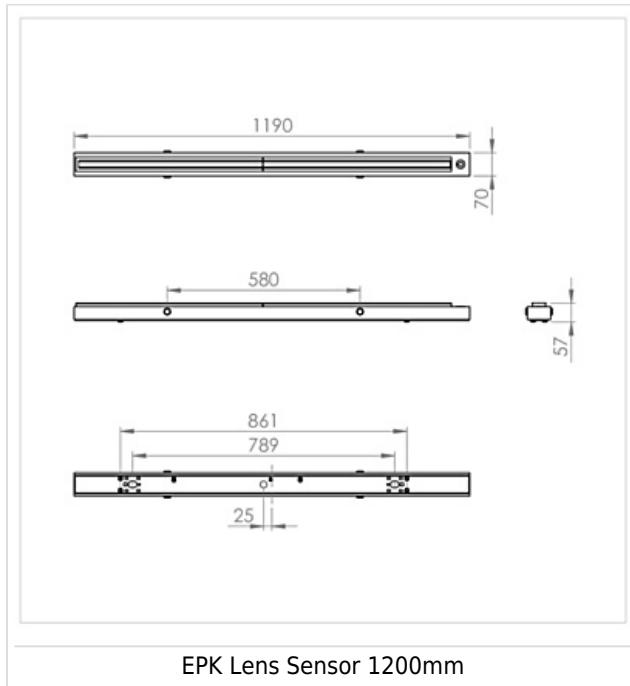

## WARRANTY

At Dextra our commitment to service has been at the forefront throughout our history spanning more than forty years in the UK lighting market. Our service ethos extends beyond design and delivery, we believe supporting your installation throughout the warranty period is equally crucial, whilst the strength and longevity of Dextra Group provides peace of mind that our warranty will be supported throughout.

The Dextra range is supplied with a five year warranty commencing from the date of delivery. During the first three years defects will be repaired on site and the warranty will include both parts and labour. For the final two years drivers, emergency modules, wireless modules, sensors and LED circuits will be supplied free of charge to replace defective components, labour and other associated costs are not included.

Certain ranges and components are subject to exemptions:

- Lithium batteries are provided with a three year warranty for parts and labour. Nickel Metal Hydride and Nickel Cadmium batteries are provided with a one year warranty for parts and labour.
- Emergency luminaires including AME LED, EXI LED, EXI2 LED, EXI Track, HBE LED, HBE2 LED, OAT2 LED, OEZ LED and Twinspot with Nickel Metal Hydride batteries are supplied with a one year warranty for parts and labour. Lithium variants of these ranges are supplied with a three year warranty for parts and labour with the exception of the AME2, EXI3, HBE3 and TWS IP65 L7 ranges which are supplied with a one year parts and labour warranty. TWS IP65 L7 in autotest and wireless variants are supplied with the standard three year lithium battery warranty.
- Protec Micro, PTECF7 Fire Rated Downlights, Serenus and the Opus Sconce are provided with a five year replacement luminaire only warranty. Protec FR Fire Rated Downlights are provided with a 2 year replacement luminaire only warranty.

- Controls systems such as standalone sensors, switches, marshalling boxes and cabling are provided with a one year warranty for both parts and labour. DALI control systems are provided with a two year warranty for both parts and labour.
- LEDextra ranges are supplied with a three year parts or replacement luminaire only warranty with the exception of the IMPR RGBW, the Runway RGBW, the MOD RGBW and the Tanek RGBW. These three ranges are supplied with our standard five year warranty during which defects within the first three years will be repaired on site and the warranty includes both parts and labour. For the final two years free of charge replacement components only will be supplied to rectify any failures but labour and other associated costs are not included.
- LEDEX ranges are supplied with a three year replacement luminaire only warranty.
- The Decorative Pendant ranges, Bebo, Dene, Nova, Fino and Stix are supplied with a 3 year replacement luminaire only warranty.

All warranties are subject to correct use of the product and will be invalidated by misuse, for example incorrect installation, unsuitable environmental conditions or incorrect maintenance. It is the duty of the customer to ensure that all the fault lies with the luminaire prior to requesting replacement parts or site repairs. In the event that no defect is found with the product our costs for attending site will be recharged to the customer and credit will not be issued against returned products. No consequential losses incurred resulting from any defect with our product will be reimbursed.

Given the nature of LED technology a small percentage of LEDs may fail during the lifetime of a luminaire, this does not cause a reduction in lumen output. As such LED luminaires are only deemed to be faulty for warranty purposes when in excess of ten percent of LEDs have failed in a single luminaire

On site repair of products under warranty will be undertaken during normal working hours, 9am to 5pm Monday to Friday, and will require unrestricted access to luminaires. Where required Dextra will provide access equipment to carry out repairs at height, should luminaires have been installed in locations where reasonable provision for maintenance access has not been made we reserve the right to supply replacement product only.

If you require any assistance with regards to our products please contact our Customer Services department on 01747 858100.

[DOWNLOAD WARRANTY PDF](#)

---

## ORDER CODES

---

LUMINAIRE

Code	Description	Power	Llm/W
EPKL L26 **	Ecopak Lens, 1200mm, 2,470lm, Colour 84	15.8W	156
EPKL L38 **	Ecopak Lens, 1200mm, 3,610lm, Colour 84	22.7W	159
EPKL L35 **	Ecopak Lens, 1700mm, 3,324lm, Colour 84	22.4W	148
EPKL L45 **	Ecopak Lens, 1700mm, 4,275lm, Colour 84	26.1W	164
EPKL L54 **	Ecopak Lens, 1700mm, 5,130lm, Colour 84	30.6W	168
EPKL L63 **	Ecopak Lens, 1700mm, 5,985lm, Colour 84	36.3W	165
EPKL L80 **	Ecopak Lens, 1700mm, 7,599lm, Colour 84	43.7W	174
EPKL L96 **	Ecopak Lens, 1700mm, 9,120lm, Colour 84	55.3W	165
EPKL L120 **	Ecopak Lens, 1700mm, 11,400lm, Colour 84	72.7W	157

Luminaire lumens figures based on OA version.

\*\* Please select Optic

### OPTIC

Code	Description
OA	Open Area
HR	High Rack
UHR	Ultra High Rack

### DIMMING

Code	Description
A	DALI Digital Addressable Lighting Interface
S	Switch Dimming
D	DSI Digital Dimming
H	HFR Analogue 1-10v
C	Bi-Level Dimming For Standalone Switched Sensor

### CONTROL

Code	Description
R21C	Reacta 21, Presence, Bi-Level Dimming, 2.5-4M
R21E	Reacta 21, Presence, On / Off, 2.5-4M
R44	Reacta 44, Presence & Daylight, 2.5-7M
RLI	Reacta-Link, Wireless Enabled Luminaire
RLS	Reacta-Link Wireless, Presence, 2.5-4M
RCS	Reacta-Control Wireless, Presence, Daylight, 2.5-4M

\* REA-AP controller required for programming

### EMERGENCY

Code	Description
LE3	Lithium Standard Emergency 3 Hour
LS3	Lithium Selftest Emergency 3 Hour
LA3	Lithium Autotest Emergency 3 Hour
LSTR	Lithium Reacta-Link Emergency 3 Hour
LA3RC	Lithium Reacta-Control Emergency 3 Hour

### MISCELLANEOUS

Code	Description
C**	Select Colour Temperature and Rendering; C83, C84, C85, C865, C93, C94
LSF	Low Smoke Zero Halogen