



PRODUCT SPECIFICATION

CAPO XL



INTRODUCTION

The Capo XL is a modern take on the classic Highbay luminaire used in countless warehouse, manufacturing and retail applications around the country. The Capo XL provides a modern and attractive appearance with similar lumen output to traditional 250W and 400W HID luminaires with typically half the energy consumption and minimal maintenance requirements ensuring that the Capo XL provides rapid return on investment in the vast majority of applications. With a matt grey or white aluminium rear housing, a translucent collar available in a range of colours and opal refractor the Capo XL can also be customised to suit any corporate theme.

The Capo XL is available in three lumen outputs, 6,513lm, 12,676lm and 17,718lm luminaire lumens ensuring it can be used as an effective replacement for the majority of HID sources and is also available in dimming and lithium emergency variants eliminating the need for costly separate emergency lighting systems. We offer a range of wireless control systems providing localised grouping and control as well as comprehensive wireless solutions allowing both standard and emergency luminaires to be centrally monitored.

**UK
CA** CE IP20 TM21: L90>60K HOURS / L80>90K HOURS 3 STEP MACADAM ELLIPSE

APPLICATION

- Industrial / Manufacturing
- Retail
- Warehouse / Storage

SPECIFICATION

CONSTRUCTION

- Housing: Spun aluminium
- Finish: Matt grey
- Diffuser: Injection moulded high transmission opal polycarbonate
- IP20
- Translucent collar available in a range of colour options.

PERFORMANCE

- Part L2 compliant
- 3SCDM Three step Macadams ellipse
- TM21: L90>60K Hours / L80>90K Hours
- Up to 85 luminaire lumens per circuit Watt.

ENVIRONMENTAL

- Designed to allow simple replacement of components with commonly available tools in compliance with the Eco Design Directive, please see the installation leaflet for maintenance instructions.
- Powered by European branded drivers and emergency modules ensuring replacement parts are easily sourced.
- Every luminaire is labelled with a unique ID number allowing easy identification of spare parts for the lifetime of the product.
- Contains no single use plastics or polystyrene packaging.
- Supplied in plain card boxes with paper tape ensuring packaging is easily recycled.
- Designed to allow simple disassembly for end of life recycling.
- UK based manufacturing providing local support throughout the product lifetime and minimising transportation miles.

EMERGENCY

- Available with optional standard, self test and autotest integral emergency with lithium batteries for extended warranty and lifetime.
- Optional Reacta-Link wireless emergency for automated centralised reporting.
- Optional Reacta-Control wireless emergency for automated centralised reporting.

CONTROL

- Optional compatibility with a range of dimming systems including DALI, DSI and Switch Dimming
- Optional integral Reacta-Link for integration with Reacta-Link wireless installations
- Optional integral Reacta-Control for integration with Reacta-Control wireless installations

INSTALLATION

- Suitable for suspended installation
- Supplied complete with single point suspension kit allowing for simple replacement of traditional highbay luminaires.

VARIATIONS

- Available with a wide range of colour temperatures and renderings
- Available in a range of lumen outputs

- Available with a range of collar colours

IMAGES

PRODUCT IMAGES



Capo XL Grey Housing



Capo XL White Housing



Capo XL Black Housing



Capo XL Opal Collar



Capo XL Green Collar



Capo XL Orange Collar

PROJECT IMAGES

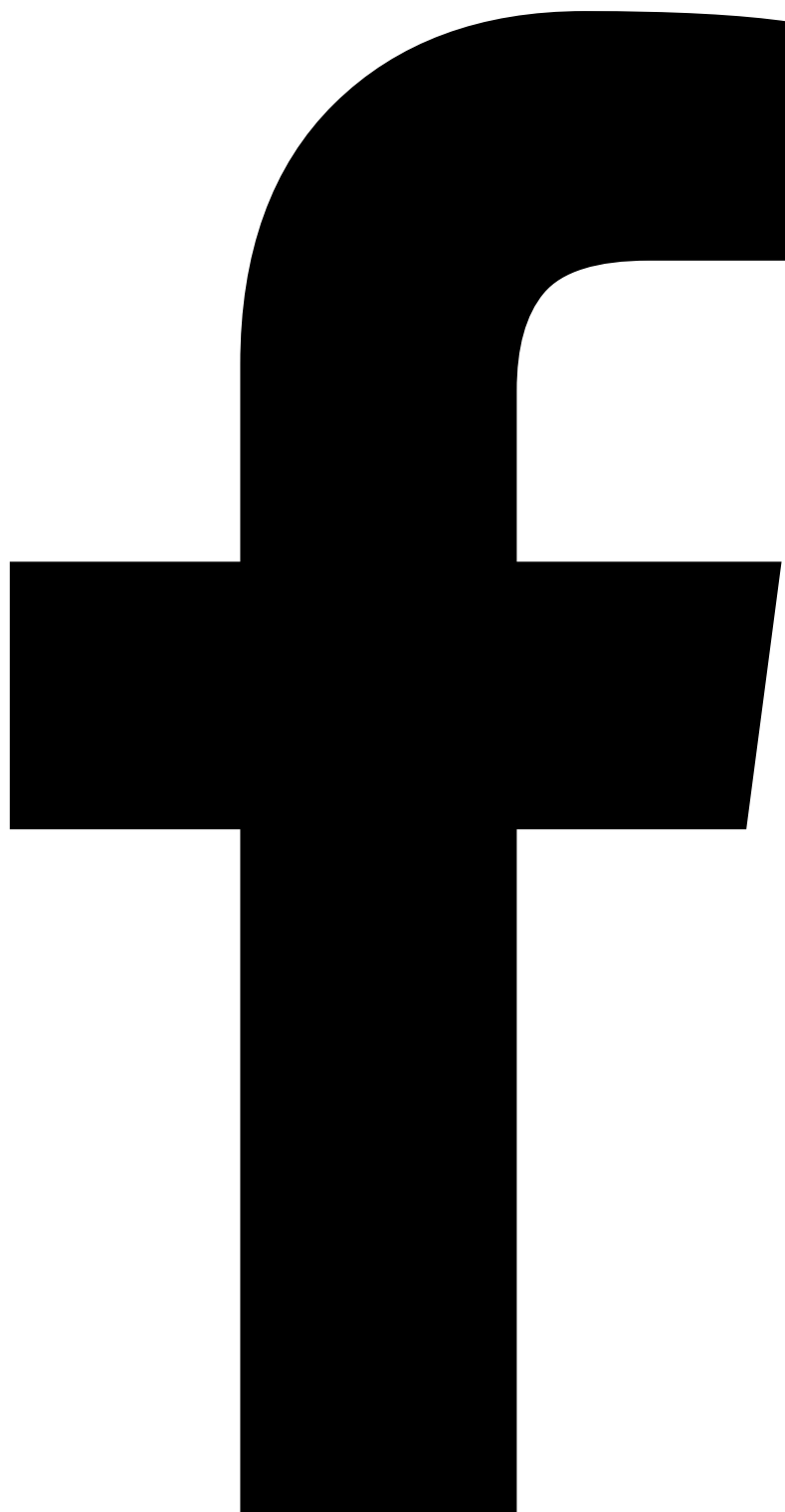



TECHNICAL

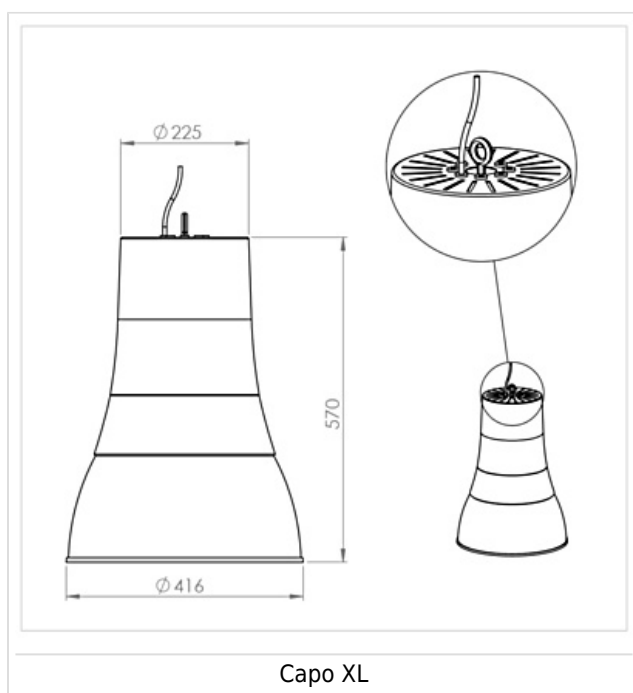

WARRANTY

At Dextra our commitment to service has been at the forefront throughout our history spanning more than forty years in the UK lighting market. Our service ethos extends beyond design and delivery, we believe supporting your installation throughout the warranty period is equally crucial, whilst the strength and longevity of Dextra Group provides peace of mind that our warranty will be supported throughout.

The Dextra range is supplied with a five year warranty commencing from the date of delivery. During the first three years defects will be repaired on site and the warranty will include both parts and labour. For the final two years drivers, emergency modules, wireless modules, sensors and LED circuits will be supplied free of charge to replace defective components, labour and other associated costs are not included.

Certain ranges and components are subject to exemptions:

- Lithium batteries are provided with a three year warranty for parts and labour. Nickel Metal Hydride and Nickel Cadmium batteries are provided with a one year warranty for parts and labour.
- Emergency luminaires including AME LED, EXI LED, EXI2 LED, EXI Track, HBE LED, HBE2 LED, OAT2 LED, OEZ LED and Twinspot with Nickel Metal Hydride batteries are supplied with a one year warranty for parts and labour. Lithium variants of these ranges are supplied with a three year warranty for parts and labour with the exception of the AME2, EXI3, HBE3 and TWS IP65 L7 ranges which are supplied with a one year parts and labour warranty. TWS IP65 L7 in autotest and wireless variants are supplied with the standard three year lithium battery warranty.
- Protec Micro, PTECF7 Fire Rated Downlights, Serenus and the Opus Sconce are provided with a five year replacement luminaire only warranty. Protec FR Fire Rated Downlights are provided with a 2 year replacement luminaire only warranty.
- Controls systems such as standalone sensors, switches, marshalling boxes and cabling are provided with a one year warranty for both parts and labour. DALI control systems are provided with a two year warranty for both parts and labour.
- LEDextra ranges are supplied with a three year parts or replacement luminaire only warranty with the exception of the IMPR RGBW, the Runway RGBW, the MOD RGBW and the Tanek RGBW. These three ranges are supplied with our standard five year warranty during which defects within the first three years will be repaired on site and the warranty includes both parts and labour. For the final two years free of charge replacement components only will be supplied to rectify any failures but labour and other associated costs are not included.
- LEDEX ranges are supplied with a three year replacement luminaire only warranty.
- The Decorative Pendant ranges, Bebo, Dene, Nova, Fino and Stix are supplied with a 3 year replacement luminaire only warranty.

All warranties are subject to correct use of the product and will be invalidated by misuse, for example incorrect installation, unsuitable environmental conditions or incorrect maintenance. It is the duty of the customer to ensure that all the fault lies with the luminaire prior to requesting replacement parts or site repairs. In the event that no defect is found with the product our costs for attending site will be recharged to the customer and credit will not be issued against returned products. No consequential losses incurred resulting from any defect with our product will be reimbursed.

Given the nature of LED technology a small percentage of LEDs may fail during the lifetime of a luminaire, this does not cause a reduction in lumen output. As such LED luminaires are only deemed to be faulty for warranty purposes when in excess of ten percent of LEDs have failed in a single luminaire

On site repair of products under warranty will be undertaken during normal working hours, 9am to 5pm Monday to Friday, and will require unrestricted access to luminaires. Where required Dextra will provide access equipment to carry out repairs at height, should luminaires have been installed in locations where reasonable provision for maintenance access has not been made we reserve the right to supply replacement product only.

If you require any assistance with regards to our products please contact our Customer Services department on 01747 858100.

[DOWNLOAD WARRANTY PDF](#)

ORDER CODES

LUMINAIRE

Code	Description	Power	Llm/W
CAP XL L80	Capo XL, 6,513llm, Grey Housing, Colour 84	76.3W	85
CAP XL L160	Capo XL, 12,676llm, Grey Housing, Colour 84	154.3W	82
CAP XL L240	Capo XL, 17,718llm, Grey Housing, Colour 84	225.3W	78

Supplied with suspension kit

DIMMING

Code	Description
A	DALI Digital Addressable Lighting Interface
S	Switch Dimming
D	DSI Digital Dimming
C	Bi-Level Dimming For Standalone Switched Sensor

The Capo XL L160 uses two drivers and the L240 uses three drivers requiring an address per driver on the DALI network.

DSI is not available in L80 variants.

CONTROL

Code	Description
RLI	Reacta-Link, Wireless Enabled Luminaire
RC	Reacta-Control, Wireless Enabled Luminaire

Please click [here](#) for full details on our wireless controls.

EMERGENCY

Code	Description
LE3	Lithium Standard Emergency 3 Hour
LS3	Lithium Selftest Emergency 3 Hour
LA3	Lithium Autotest Emergency 3 Hour
LSTR	Lithium Reacta-Link Emergency 3 Hour
LA3RC	Lithium Reacta-Control Emergency 3 Hour

MISCELLANEOUS

Code	Description
C**	Select Colour Temperature and Rendering; C83, C84, C85, C865, C93, C94
WH	White Finish
BL	Black Finish
RED	Red Collar
ORA	Orange Collar
GRN	Green Collar
BLE	Blue Collar
OP	Opal Collar
LSF	Low Smoke Zero Halogen

Collar colours may be subject to minimum order quantity