



# PRODUCT SPECIFICATION

---

AME WIRELESS



---

## INTRODUCTION

---

The AME Wireless is an LED emergency bulk head emergency luminaire incorporating lithium batteries for extended lifetime. With a white polycarbonate housing and clear polycarbonate diffuser the AME Wireless is both IP65 rated to protect from dust and water and able to withstand light impact. The AME Wireless is also available with adhesive legends to ensure that it can be used either for general emergency illumination or for emergency signage. The AME Wireless is supplied with Reacta-Link wireless as standard providing automatic emergency testing and centralised reporting of test results and failures substantially reducing the operating costs of your emergency installation.

**UK  
CA** CE IP65 IK07

---

## APPLICATION

---

- Accent Lighting
- Canteen
- Commercial / Offices
- Corridor
- Display Lighting
- Education
- Exterior
- Food / Clean Area

- Healthcare / Social Housing
- Hotel / Leisure
- Industrial / Manufacturing
- Kitchen
- Office
- Parking / Exterior
- Retail
- Specialist Applications
- Stairwell
- Store Room
- Toilet
- Transport
- Warehouse / Storage

---

## SPECIFICATION

---

### CONSTRUCTION

- Housing: Injection moulded polycarbonate
- Finish: Matt white
- Diffuser: Injection moulded clear polycarbonate
- ISO 7010 or Euro Norm Legends with all directional arrow options.
- IK07
- IP65

### ENVIRONMENTAL

- Designed to allow simple replacement of components with commonly available tools in compliance with the Eco Design Directive, please see the installation leaflet for maintenance instructions.
- All critical components are mounted on a single tray for simple end of life repair or upgrade.
- Powered by European branded drivers and emergency modules ensuring replacement parts are easily sourced.
- Every luminaire is labelled with a unique ID number allowing easy identification of spare parts for the lifetime of the product.
- Contains no single use plastics or polystyrene packaging.
- Supplied in plain card boxes with paper tape ensuring packaging is easily recycled.
- Designed to allow simple disassembly for end of life recycling.
- UK based manufacturing providing local support throughout the product lifetime and minimising transportation miles.

### EMERGENCY

- Optional Reacta-Link wireless emergency for automated centralised reporting.
- Optional Reacta-Control wireless emergency for automated centralised reporting.

## CONTROL

- Optional compatibility with a range of dimming systems including DALI, DSI and Switch Dimming

## INSTALLATION

- Suitable for conduit installation
- Suitable for surface installation

## IMAGES

### PRODUCT IMAGES



AME Wireless



AME Wireless with Legend

## TECHNICAL

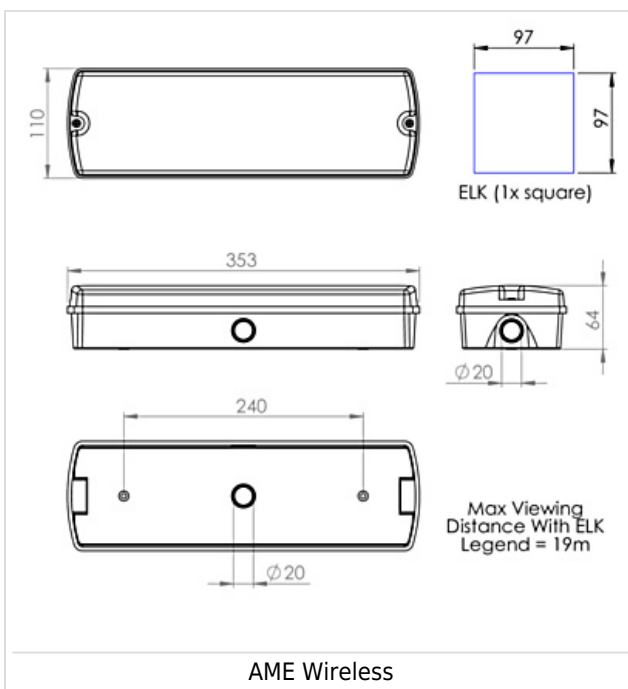

AME Wireless

---

## WARRANTY

---

At Dextra our commitment to service has been at the forefront throughout our history spanning more than forty years in the UK lighting market. Our service ethos extends beyond design and delivery, we believe supporting your installation throughout the warranty period is equally crucial, whilst the strength and longevity of Dextra Group provides peace of mind that our warranty will be supported throughout.

The Dextra range is supplied with a five year warranty commencing from the date of delivery. During the first three years defects will be repaired on site and the warranty will include both parts and labour. For the final two years drivers, emergency modules, wireless modules, sensors and LED circuits will be supplied free of charge to replace defective components, labour and other associated costs are not included.

Certain ranges and components are subject to exemptions:

- Lithium batteries are provided with a three year warranty for parts and labour. Nickel Metal Hydride and Nickel Cadmium batteries are provided with a one year warranty for parts and labour.
- Emergency luminaires including AME LED, EXI LED, EXI2 LED, EXI Track, HBE LED, HBE2 LED, OAT2 LED, OEZ LED and Twinspot with Nickel Metal Hydride batteries are supplied with a one year warranty for parts and labour. Lithium variants of these ranges are supplied with a three year warranty for parts and labour with the exception of the AME2, EXI3, HBE3 and TWS IP65 L7 ranges which are supplied with a one year parts and labour warranty. TWS IP65 L7 in autotest and wireless variants are supplied with the standard three year lithium battery warranty.
- Protec Micro, PTECF7 Fire Rated Downlights, Serenus and the Opus Sconce are provided with a five year replacement luminaire only warranty. Protec FR Fire Rated Downlights are provided with a 2 year replacement luminaire only warranty.
- Controls systems such as standalone sensors, switches, marshalling boxes and cabling are provided with a one year warranty for both parts and labour. DALI control systems are provided with a two year warranty for both parts and labour.
- LEDextra ranges are supplied with a three year parts or replacement luminaire only warranty with the exception of the IMPR RGBW, the Runway RGBW, the MOD RGBW and the Tanek RGBW. These three ranges are supplied with our standard five year warranty during which defects within the first three years will be repaired on site and the warranty includes both parts and labour. For the final two years free of charge replacement components only will be supplied to rectify any failures but labour and other associated costs are not included.
- LEDEX ranges are supplied with a three year replacement luminaire only warranty.
- The Decorative Pendant ranges, Bebo, Dene, Nova, Fino and Stix are supplied with a 3 year replacement luminaire only warranty.

All warranties are subject to correct use of the product and will be invalidated by misuse, for example incorrect installation, unsuitable environmental conditions or incorrect maintenance. It is the duty of the customer to ensure that all the fault lies with the luminaire prior to requesting replacement parts or site repairs. In the event that no defect is found with the product our costs for attending site will be recharged to the customer and credit will not be issued against returned products. No consequential losses incurred resulting from any defect with our product will be reimbursed.

Given the nature of LED technology a small percentage of LEDs may fail during the lifetime of a luminaire, this does not cause a reduction in lumen output. As such LED luminaires are only deemed to be faulty for warranty purposes when in excess of ten percent of LEDs have failed in a single luminaire

On site repair of products under warranty will be undertaken during normal working hours, 9am to 5pm Monday to Friday, and will require unrestricted access to luminaires. Where required Dextra will provide access equipment to carry out repairs at height, should luminaires have been installed in locations where reasonable provision for maintenance access has not been made we reserve the right to supply replacement product only.

If you require any assistance with regards to our products please contact our Customer Services department on 01747 858100.

[DOWNLOAD WARRANTY PDF](#)

---

## ORDER CODES

---

### LUMINAIRE

Code	Description	Power
AME LED NM3 LA3RC	AME Wireless, Lithium Non Maintained, Reacta-Control Emergency 3 Hour	2.5W
AME LED M3 LA3RC	AME Wireless, Lithium Maintained, Reacta-Control Emergency 3 Hour	2.5W
AME LED NM3 LSTR	AME Wireless, Lithium Non Maintained, Reacta-Link Emergency 3 Hour	2.5W
AME LED M3 LSTR	AME Wireless, Lithium Maintained, Reacta-Link Emergency 3 Hour	2.5W

### MISCELLANEOUS

Code	Description
LSF	Low Smoke Zero Halogen
AME ELK	Emergency Legend Kit
AME ELK ISO	Emergency Legend Kit, ISO 7010