

Discalo Installation

220-240V / 50-60Hz
IP20



WARNING: Luminaire must be earthed. Risk of electric shock from LED boards if operated with cover removed. Installation / operation outside of luminaires intended scope invalidates warranty. Suitable only for domestic / light industrial / industrial applications within the scope of EN55015. Tested to compliance with BSEN 60598: specification for general requirements and tests. Must be installed by a suitably qualified person in accordance with all relevant legislation. Ambient operating temperature of 0°C to 25°C. If maximum operating temperature is exceeded luminaire will automatically dim / switch off. Terminal blocks are rated to 16A unless stated otherwise. The light source contained in this luminaire shall only be replaced by the manufacturer or his service agent or a similar qualified person. **LUMINAIRES WITH EMERGENCY PACK:** When supply is isolated battery output terminals may be live if battery is connected. Isolate mains and battery before servicing. Emergency luminaires require unswitched live connection taken from same phase as switched supply. When unswitched supply is connected status indicator illuminates green, when unswitched supply is disconnected indicator extinguishes and luminaire operates in emergency mode. 24 hour charge period required before undertaking full discharge test. Emergency test sheets provided should be used to record all emergency tests. Batteries should be replaced when 3 hour duration is not met. Excessive switching of permanent live may result in premature battery failure. Battery electrolyte can be harmful to eyes / open wounds, do not puncture, if electrolyte touches skin / eyes flush with water. Do not incinerate batteries.

Terminal Labelling:	
Power	
L1	Switched Live
E	Earth
N	Neutral
Emergency	
L2	Unswitched Live
DA/AT3	DALI Autotest
DA/AT3	DALI Autotest
Dimming	
-D1/DA	Analogue/DSI/DALI
+D2/DA	Analogue/DSI/DALI
L3	Switch Dim / Corridor Function

1.

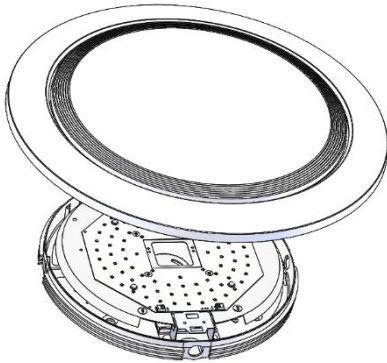

Carefully remove the front outer ring and diffuser by gently pulling around the outer edge. Set aside somewhere safe.

2.

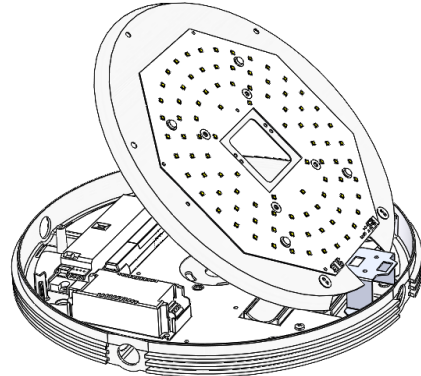

Loosen screw – open cover the access base unit.

3.

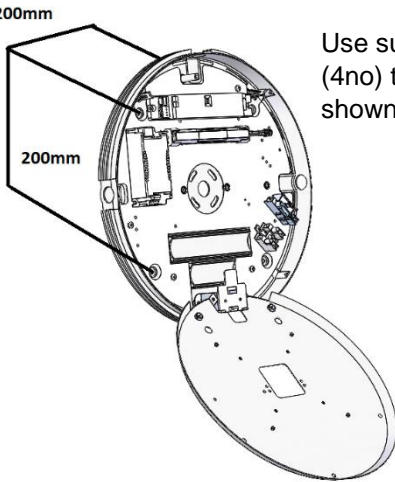

Use suitable fixings (4no) to dimensions shown below.

4.

Feed the mains cable in through one of the designated cable entries and connect to terminal block(s). Ensure cable is secured in cable clamp

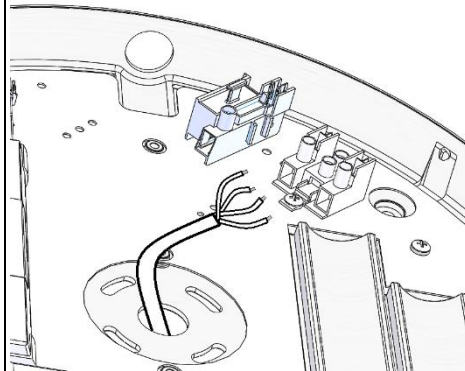

On emergency fittings, LED should be mounted in to specific cable entry plug.

5.

Re-fit cover.

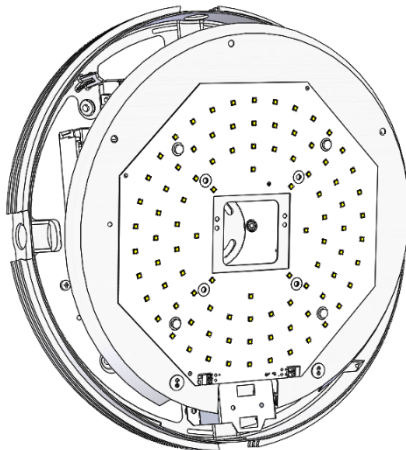

6.

Ensure slots in diffuser ring are accurately aligned with 'pegs' in aluminium base.

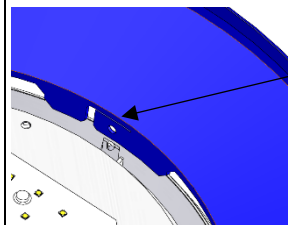

To attach diffuser engage slots on to pegs and rotate anti-clockwise.

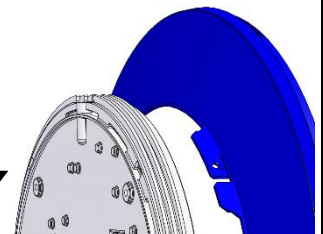

Discalo Installation

7. Suspended

Feed clutch through back of fitting.

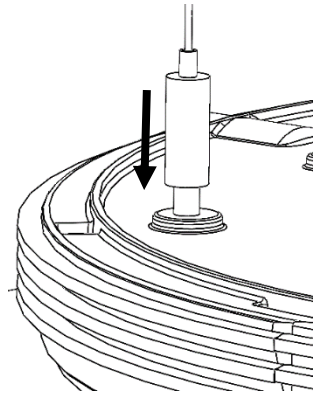

8.

Fix nut from inside of fitting onto the clutch and cut wire to desired length.

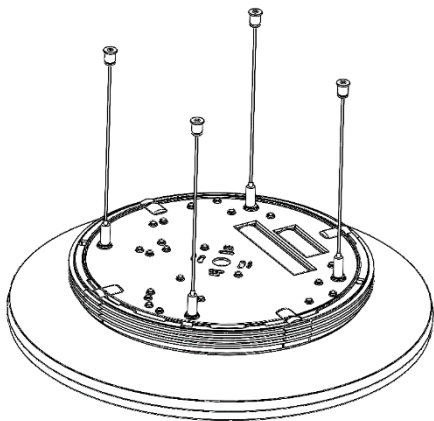
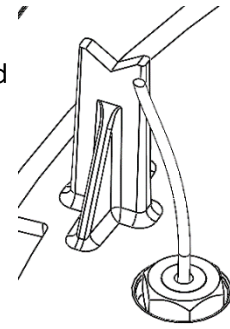

Maintenance

- 1 Disconnect luminaire before undertaking any maintenance or cleaning.
- 2 Cleaning should be undertaken on external parts of the luminaire only using a slightly damp lint free cloth.
- 3 To access fitting turn the diffuser anticlockwise to remove.
- 4 Use a pan pozi screwdriver to access gear tray and remove components.
- 5 Please contact Dextra for assistance with spare component supply.

