

220-240V / 50-60Hz

IP20

IK09



WARNING: Luminaire must be earthed. Risk of electric shock from LED boards if operated with cover removed. Installation / operation outside of luminaires intended scope invalidates warranty. Suitable only for domestic / light industrial / industrial applications within the scope of EN55015. Tested to compliance with BSEN 60598: specification for general requirements and tests. Must be installed by a suitably qualified person in accordance with all relevant legislation. Ambient operating temperature of 0°C to 25°C. If maximum operating temperature is exceeded luminaire will automatically dim / switch off. Terminal blocks are rated to 16A unless stated otherwise. The light source contained in this luminaire shall only be replaced by the manufacturer or his service agent or a similar qualified person. **LUMINAIRES WITH EMERGENCY PACK:** When supply is isolated battery output terminals may be live if battery is connected. Isolate mains and battery before servicing. Emergency luminaires require unswitched live connection taken from same phase as switched supply. When unswitched supply is connected status indicator illuminates green, when unswitched supply is disconnected indicator extinguishes and luminaire operates in emergency mode. 24 hour charge period required before undertaking full discharge test. Emergency test sheets provided should be used to record all emergency tests. Batteries should be replaced when 3 hour duration is not met. Excessive switching of permanent live may result in premature battery failure. Battery electrolyte can be harmful to eyes / open wounds, do not puncture, if electrolyte touches skin / eyes flush with water. Do not incinerate batteries.

Terminal Labelling:	
Power	
L1	Switched Live
E	Earth
N	Neutral
Emergency	
L2	Unswitched Live
DA/AT3	DALI Autotest
DA/AT3	DALI Autotest
Dimming	
-/D1/DA	Analogue/DSI/DALI
+/D2/DA	Analogue/DSI/DALI
L3	Switch Dim / Corridor Function

1.

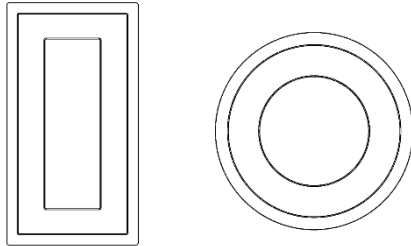

Available in two forms (rectangular or circular).
Installation process will be the same for either shape.

WALL MOUNT ONLY!

2.

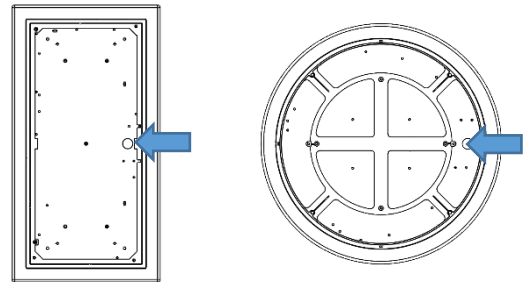

IMPORTANT

Cable entry is offset from the centre of the fitting.

Rectangular = **90mm** from centre

Circular = **160mm** from centre

3.

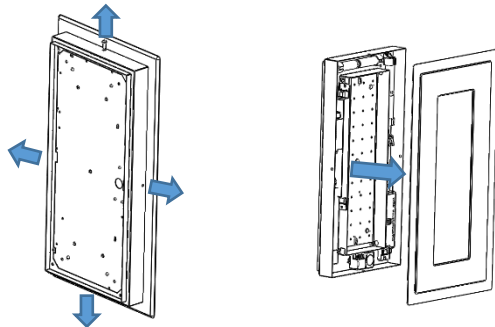

Unscrew the 4 sidewall fixing screws, then remove the front diffuser section from the housing.

4.

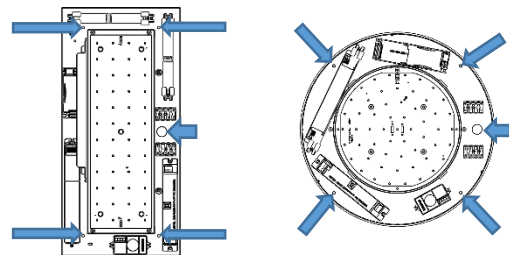

Bring the power lead through the cable entry hole. Then screw the housing to the wall using the fixing points.

Wall Mounted Orientation:

Cable entry hole to be in the 3 o'clock position.

5.

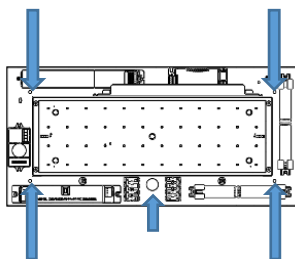

Rectangular – If mounting the fitting horizontally, cable entry hole to be in the 6 o'clock position. This will ensure that the emergency indicator is visible.

6.

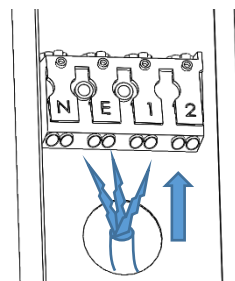

Make the electrical connection to the terminal block.

Volito Installation

7.

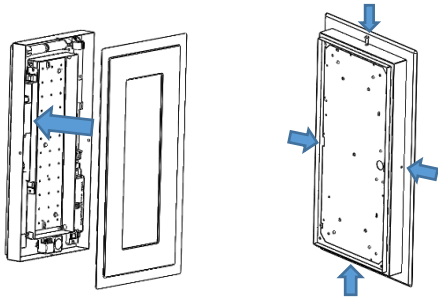

Rectangular – (for circular fitting skip to step 7 & 8)
Offer the diffuser up to the housing
(Fittings with sensors can be connected at this point).
Secure in place with the 4 fixing screws.

8.

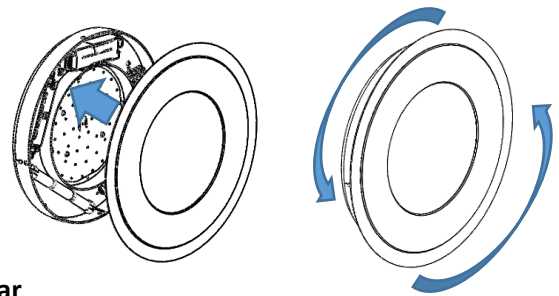

Circular
Offer diffuser up to housing. Rotate Diffuser anti clockwise until you hit the stop and the fixing holes have aligned.

9.

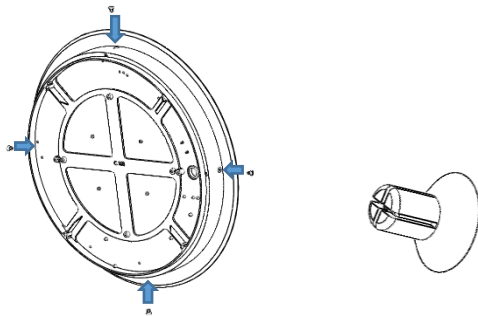

Secure the diffuser in place using the 4 white plastic push rivets supplied (bagged separately).

10.

Maintenance

- 1 Disconnect luminaire before undertaken maintenance or cleaning.
- 2 Cleaning should be undertaken on external parts of the luminaire only using a slightly damp lint free cloth.
- 3 To access rectangular Volito use an Allen Key to remove all screws from fitting then remove front diffuser.
- 4 To access circular Volito remove plastic rivets using a flat head screwdriver, then twist to diffuser to remove.
- 5 Use a pan pozi screwdriver to remove components.
- 6 Please contact Dextra for assistance with spare component supply.

