

Rubix Flush (Pull-Up) Installation

220-240V / 50-60Hz

IP20



Terminal Labelling:

| | |
|------------------|--------------------------------|
| Power | |
| L1 | Switched Live |
| E | Earth |
| N | Neutral |
| Emergency | |
| L2 | Unswitched Live |
| DA/AT3 | DALI Autotest |
| DA/AT3 | DALI Autotest |
| Dimming | |
| -/D1/DA | Analogue/DSI/DALI |
| +/D2/DA | Analogue/DSI/DALI |
| L3 | Switch Dim / Corridor Function |

WARNING: Luminaire must be earthed. Risk of electric shock from LED boards if operated with cover removed. Installation / operation outside of luminaires intended scope invalidates warranty. Suitable only for domestic / light industrial / industrial applications within the scope of EN55015. Tested to compliance with BSEN 60598: specification for general requirements and tests. Must be installed by a suitably qualified person in accordance with all relevant legislation. Ambient operating temperature of 0°C to 25°C. If maximum operating temperature is exceeded luminaire will automatically dim / switch off. Terminal blocks are rated to 16A unless stated otherwise. The light source contained in this luminaire shall only be replaced by the manufacturer or his service agent or a similar qualified person. **LUMINAIRES WITH EMERGENCY PACK:** When supply is isolated battery output terminals may be live if battery is connected. Isolate mains and battery before servicing. Emergency luminaires require unswitched live connection taken from same phase as switched supply. When unswitched supply is connected status indicator illuminates green, when unswitched supply is disconnected indicator extinguishes and luminaire operates in emergency mode. 24 hour charge period required before undertaking full discharge test. Emergency test sheets provided should be used to record all emergency tests. Batteries should be replaced when 3 hour duration is not met. Excessive switching of permanent live may result in premature battery failure. Battery electrolyte can be harmful to eyes / open wounds, do not puncture, if electrolyte touches skin / eyes flush with water. Do not incinerate batteries.

1.

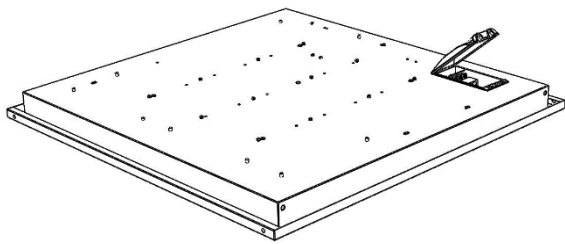

Fitting is supplied as one-piece unit. x2 rails and x4 brackets supplied loose. Fitting measures 599X599mm – designed to pull-up <clamp> to various ceilings

2.

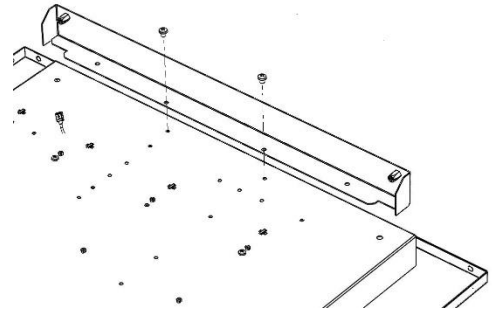

Fit adapter rails to rear of housing using 2No M4x5 self-tap screws as shown

3.

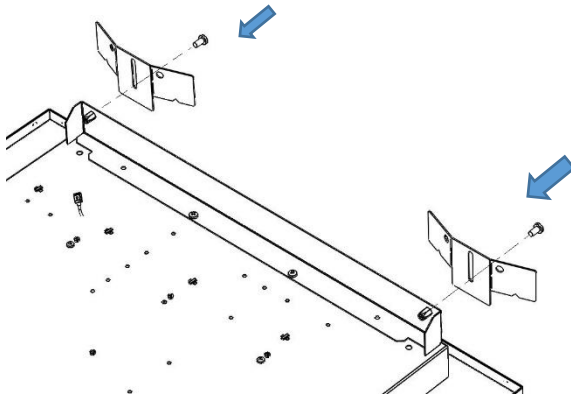

Fit brackets (part bent as shown) to rail – 2 brackets fit one rail – x2

4.

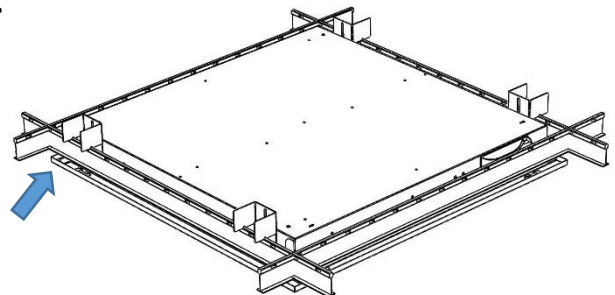

Regardless of ceiling type, the fixture should be offered up in aperture, then all brackets bent as shown – fixture will hang below ceiling....

5.

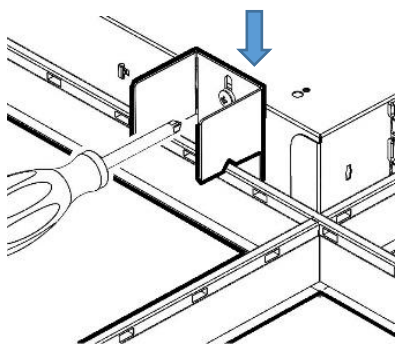

.. each bracket should be adjusted, ensuring fixture is tight against grid / level with tiles where applicable)... exposed T grid shown. Tighten screws on all brackets

6.

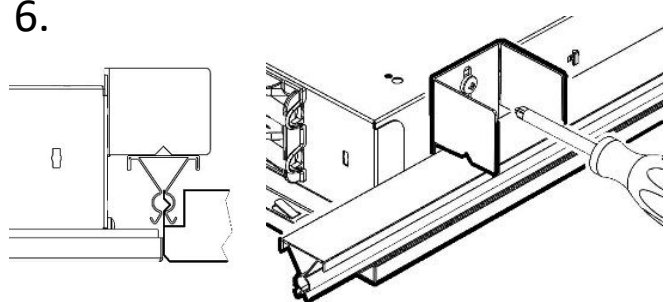

SAS 120 clip-in, fixture stops up against concealed T bar

Rubix Flush (Pull-Up) Installation

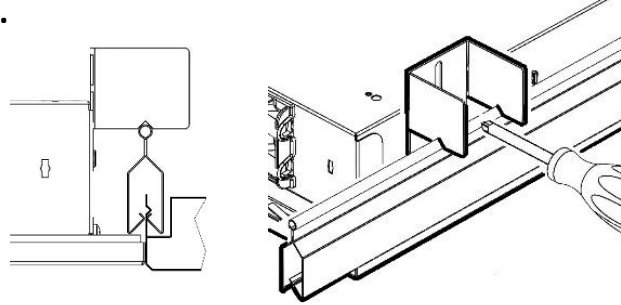
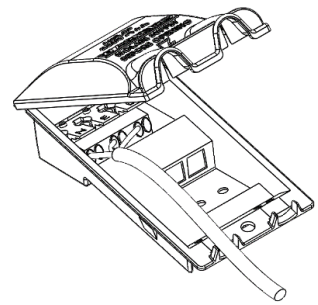
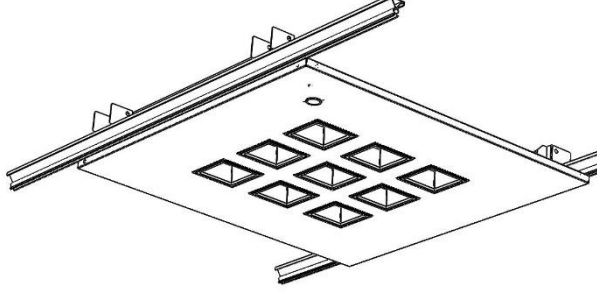
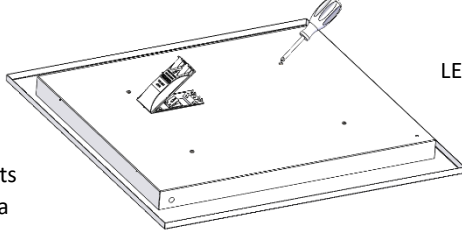
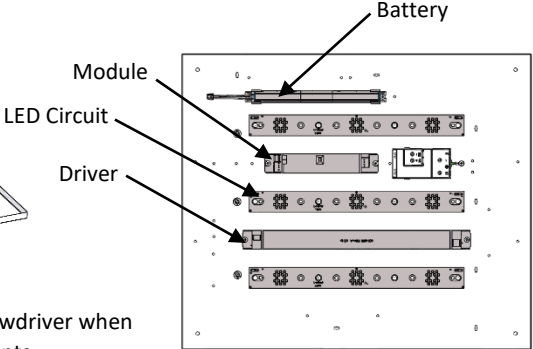
| | |
|--|---|
| <p>7.</p>  <p>SAS 150 clip-in, fixture stops up against concealed T bar</p> | <p>8.</p>  <p>Electrical connection is made via integrated connection back-flap – allows for LEN L1 (emergency) and D1/D2 <or +/- for 1-10v> where specified.</p> |
| <p>9.</p>  <p>Installed fixture on SAS 120 grid (Sensored / Emergency version shown)</p> | |
| <p><u>Maintenance</u></p> <div style="display: flex; justify-content: space-between;"> <div style="width: 45%;"> <ol style="list-style-type: none"> ① Disconnect luminaire before undertaking any maintenance or cleaning. ② Cleaning should be undertaken on external parts of the luminaire only using a slightly damp lint free cloth. ③ To remove rear housing use a pan pozi screwdriver to remove screws. </div> <div style="width: 45%; text-align: center;">  </div> </div> <div style="display: flex; justify-content: space-between; margin-top: 20px;"> <div style="width: 45%;"> <ol style="list-style-type: none"> ④ Use a pan pozi screwdriver when removing components. ⑤ Please contact Dextra for assistance with spare component supply. </div> <div style="width: 45%; text-align: center;">  </div> </div> | |
| | |