

Retro-Line Installation

220-240V / 50-60Hz
IP20



Terminal Labelling:

Power	
L1	Switched Live
E	Earth
N	Neutral
Emergency	
L2	Unswitched Live
DA/AT3	DALI Autotest
DA/AT3	DALI Autotest
Dimming	
-D1/DA	Analogue/DSI/DALI
+D2/DA	Analogue/DSI/DALI
L3	Switch Dim / Corridor Function

WARNING: Luminaire must be earthed. Risk of electric shock from LED boards if operated with cover removed. Installation / operation outside of luminaires intended scope invalidates warranty. Suitable only for domestic / light industrial / industrial applications within the scope of EN55015. Tested to compliance with BSEN 60598: specification for general requirements and tests. Must be installed by a suitably qualified person in accordance with all relevant legislation. Ambient operating temperature of 0°C to 25°C. If maximum operating temperature is exceeded luminaire will automatically dim / switch off. Terminal blocks are rated to 16A unless stated otherwise. The light source contained in this luminaire shall only be replaced by the manufacturer or his service agent or a similar qualified person. **LUMINAIRES WITH EMERGENCY PACK:** When supply is isolated battery output terminals may be live if battery is connected. Isolate mains and battery before servicing. Emergency luminaires require unswitched live connection taken from same phase as switched supply. When unswitched supply is connected status indicator illuminates green, when unswitched supply is disconnected indicator extinguishes and luminaire operates in emergency mode. 24 hour charge period required before undertaking full discharge test. Emergency test sheets provided should be used to record all emergency tests. Batteries should be replaced when 3 hour duration is not met. Excessive switching of permanent live may result in premature battery failure. Battery electrolyte can be harmful to eyes / open wounds, do not puncture, if electrolyte touches skin / eyes flush with water. Do not incinerate batteries.

1. Phase Selection

WARNING – ENSURE MAINS POWER IS ISOLATED!
Switch the L conductors (brown wire from control gear to terminal block) to either L1, L2 or L3.



2.

Check trunking is secure and clear of any obstructions.

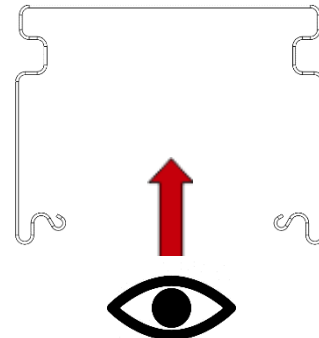

3.

Flex suspension bracket open.

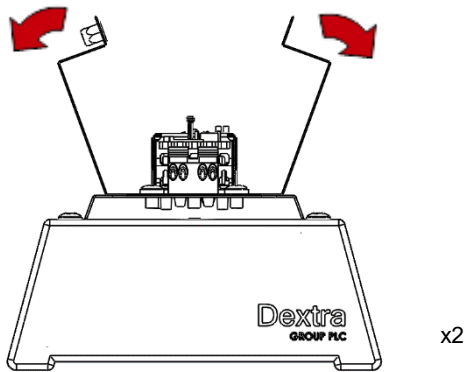

Lift fitting to trunking. Brackets will snap shut, and temporarily suspend fitting.

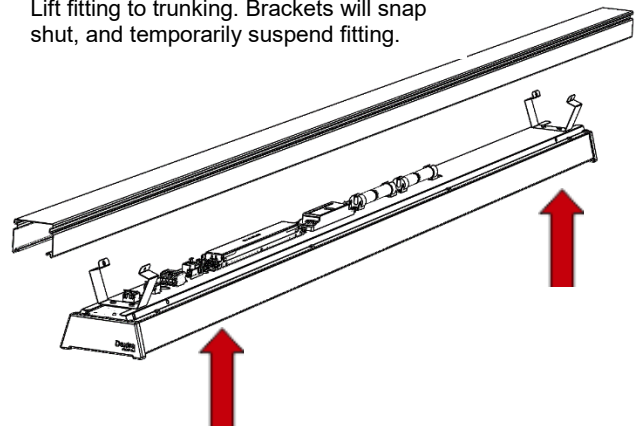

4. Pass tether over trunking and secure toggle on opposite side.

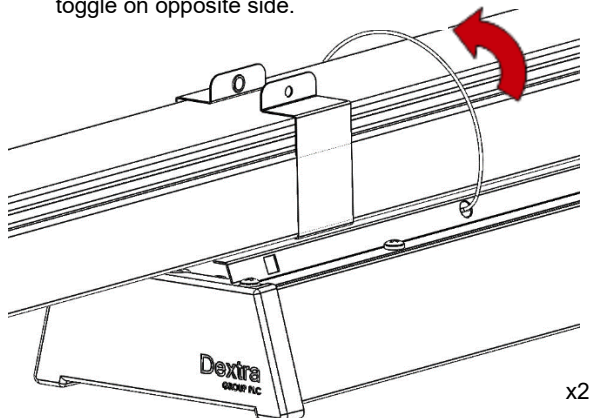

5. Fasten M4x35 locking screw into spring bracket.

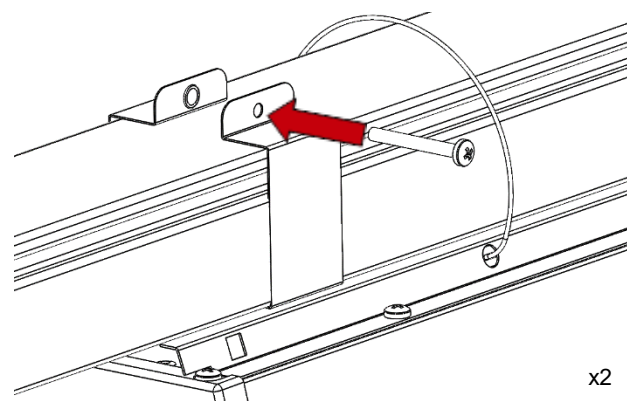

Retro-Line Installation

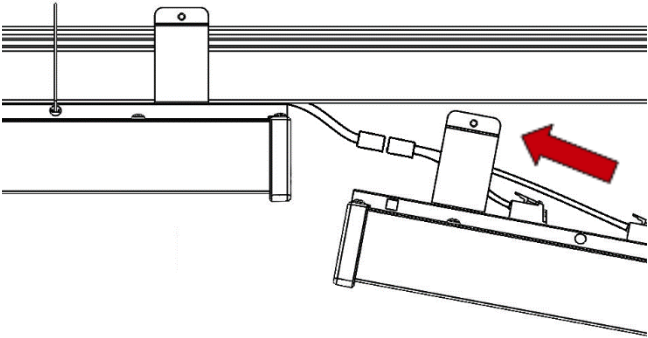
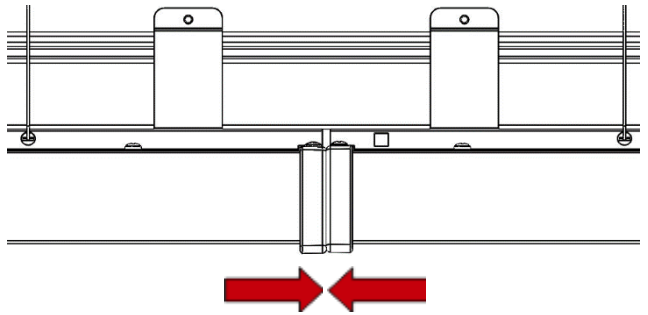
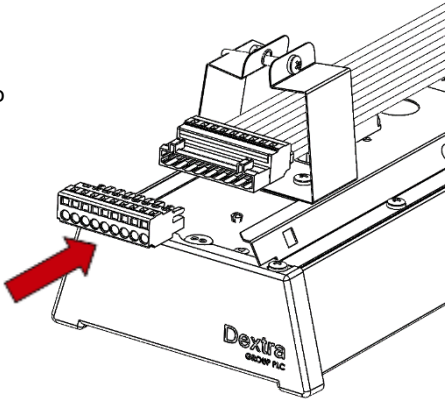
<p>6.</p> <p>Take next fitting. Repeat steps 1 and 2.</p>	<p>7. Raise to trunking, make electrical connection.</p> 
<p>8.</p> <p>Repeat steps 3, 4, 5 and 6.</p>	<p>9. Ensure fittings are touching end-to-end with no gap</p> 
<p>10.</p> <p>When the power feed is brought into the middle of a run with through-wire luminaires, a female connector must be attached to the male end of the wiring loom.</p> 	<p>11.</p> <p>3.0m – Start/Through Wire 2.0m – Start/Through Wire 1.5m – End of Run ONLY 1.0m – End of Run ONLY 0.5m – End of Run ONLY</p>
<p>Maintenance</p> <ol style="list-style-type: none"> 1 Disconnect luminaire before undertaking any maintenance or cleaning. 2 Cleaning should be undertaken on external parts of the luminaire only using a slightly damp lint free cloth. 3 Use a pan pozi screwdriver to remove endcaps from fitting to slide diffuser out. LED circuits are now accessible. 4 Use a pan pozi screwdriver to remove components. 5 Please contact Dextra for assistance with spare component supply. 