

## Runway RGBW Recessed Installation

220-240V / 50-60Hz  
IP20



Terminal Labelling:	
<b>Power</b>	
L1	Switched Live
E	Earth
N	Neutral
<b>Emergency</b>	
L2	Unswitched Live
DA/AT3	DALI Autotest
DA/AT3	DALI Autotest
<b>Dimming</b>	
-/D1/DA	Analogue/DSI/DALI
+/D2/DA	Analogue/DSI/DALI
L3	Switch Dim / Corridor Function

**WARNING:** Luminaire must be earthed. Risk of electric shock from LED boards if operated with cover removed. Installation / operation outside of luminaires intended scope invalidates warranty. Suitable only for domestic / light industrial / industrial applications within the scope of EN55015. Tested to compliance with BSEN 60598: specification for general requirements and tests. Must be installed by a suitably qualified person in accordance with all relevant legislation. Ambient operating temperature of 0°C to 25°C. If maximum operating temperature is exceeded luminaire will automatically dim / switch off. Terminal blocks are rated to 16A unless stated otherwise. The light source is non replaceable. **LUMINAIRES WITH EMERGENCY PACK:** When supply is isolated battery output terminals may be live if battery is connected. Isolate mains and battery before servicing. Emergency luminaires require unswitched live connection taken from same phase as switched supply. When unswitched supply is connected status indicator illuminates green, when unswitched supply is disconnected indicator extinguishes and luminaire operates in emergency mode. 24 hour charge period required before undertaking full discharge test. Emergency test sheets provided should be used to record all emergency tests. Batteries should be replaced when 3 hour duration is not met. Excessive switching of permanent live may result in premature battery failure. Battery electrolyte can be harmful to eyes / open wounds, do not puncture, if electrolyte touches skin / eyes flush with water. Do not incinerate batteries.

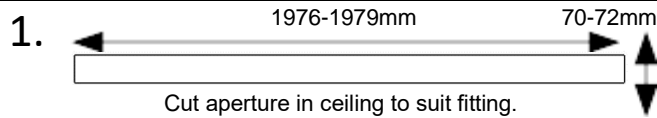

Cut aperture in ceiling to suit fitting.

**Caution:**

All red, green and blue can be run at the same time, however white can only be run with one additional colour. The fitting must not run all 4 colours at the same time. Drivers come programmed to prevent operation above 50% output when not connected to a DALI system, however commissioning will reset these values, we strongly recommend these values are programmed during commissioning to prevent overheating should the DALI system fail.

Under no circumstances should the LEDs in this luminaire be viewed directly, only illuminate this product with the diffuser installed. Directly viewing the LEDs in this luminaire has the potential to damage eyesight.

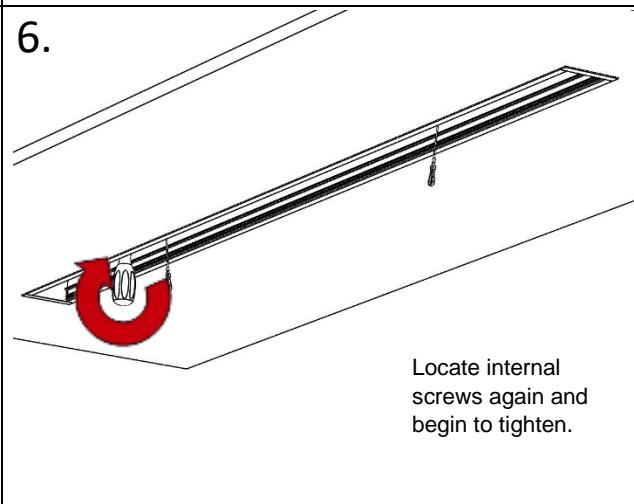
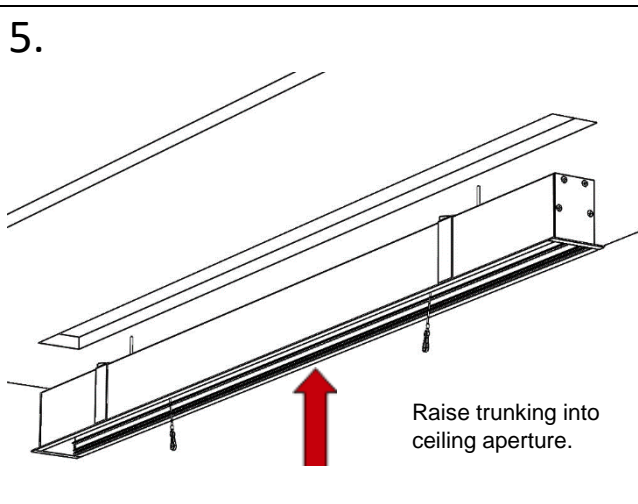
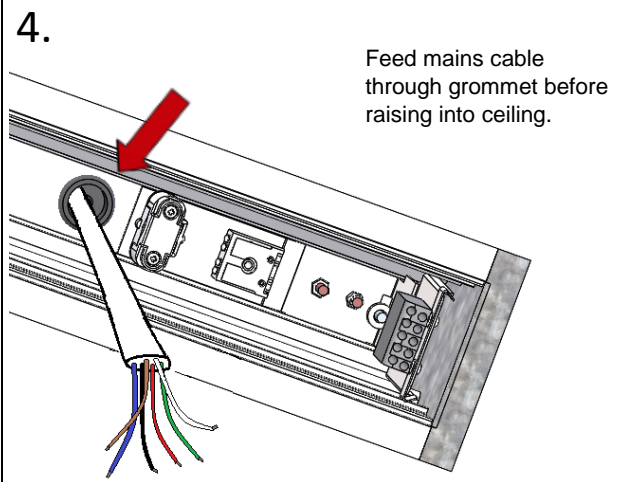
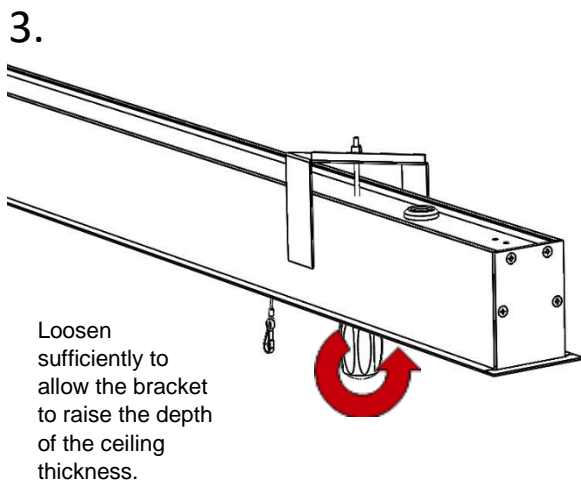
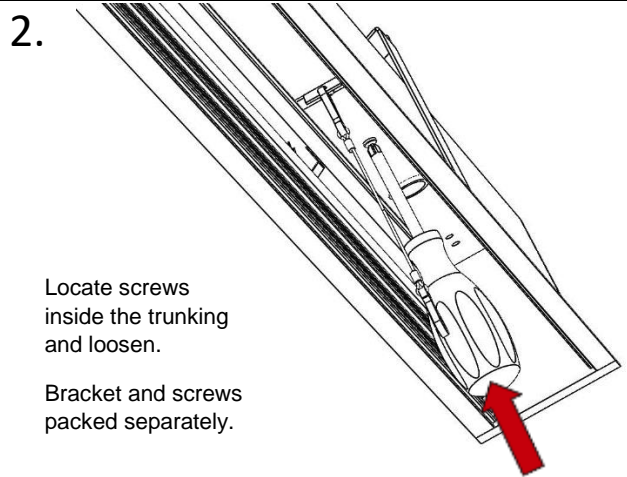

## Runway RGBW Recessed Installation

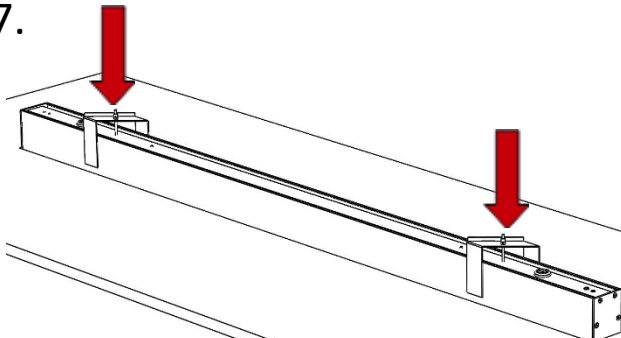
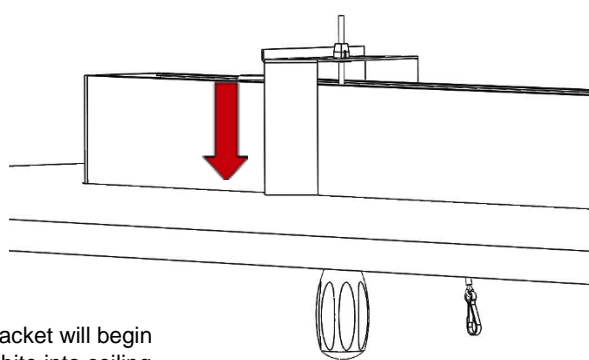
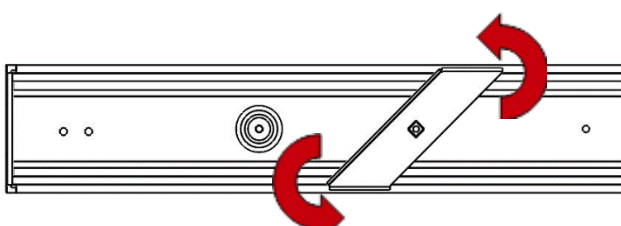
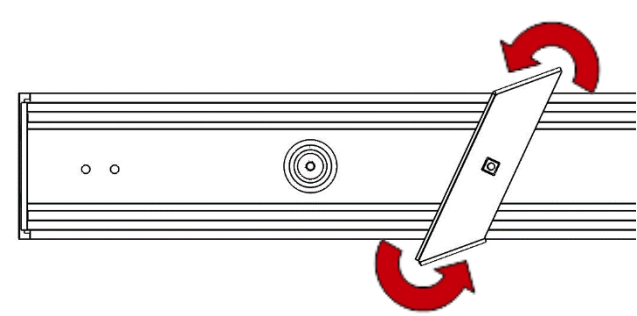
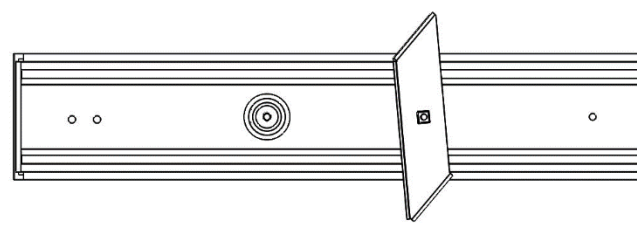
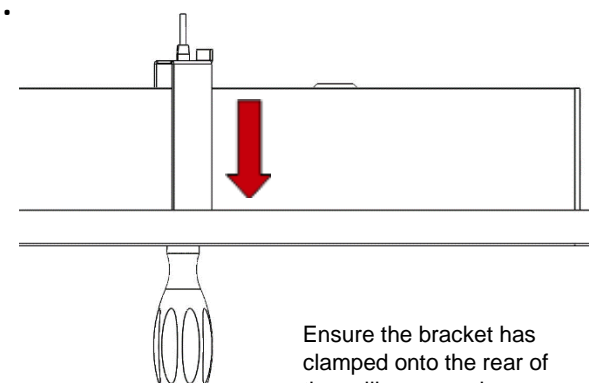
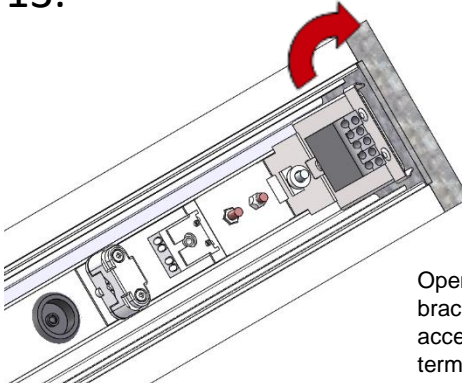
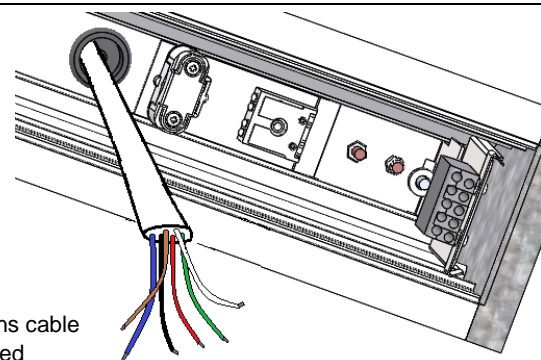
<p>7.</p>  <p>As the screws are tightened, the brackets will rotate and tighten against the rear of the ceiling.</p>	<p>8.</p>  <p>Bracket will begin to bite into ceiling.</p>
<p>9.</p>  <p>Bracket beginning to rotate.</p>	<p>10.</p>  <p>Bracket will rotate as shown as screw is tightened.</p>
<p>11.</p>  <p>Bracket fully rotated.</p>	<p>12.</p>  <p>Ensure the bracket has clamped onto the rear of the ceiling securely.</p>
<p>13.</p>  <p>Open the starter bracket to allow access to the terminal block.</p>	<p>14.</p>  <p>Wire mains cable into marked terminals as required.</p>

## Runway RGBW Recessed Installation

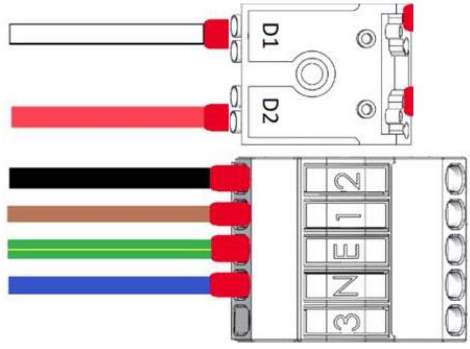
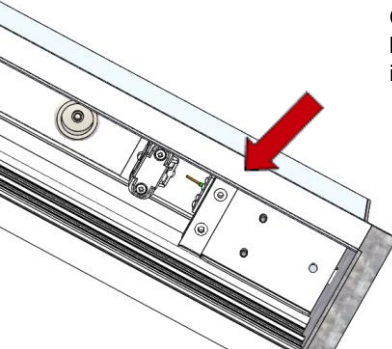
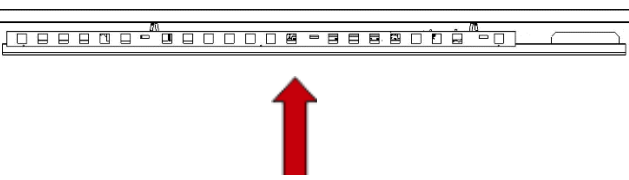
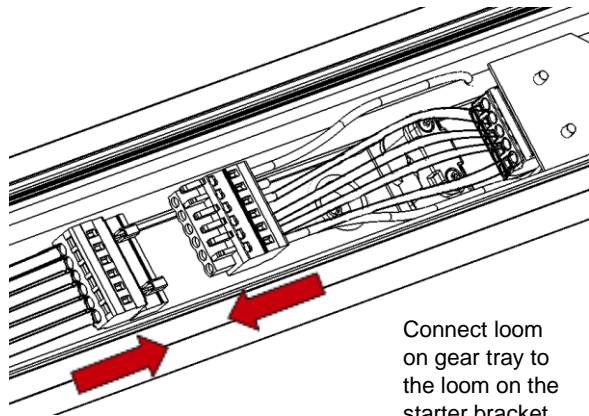
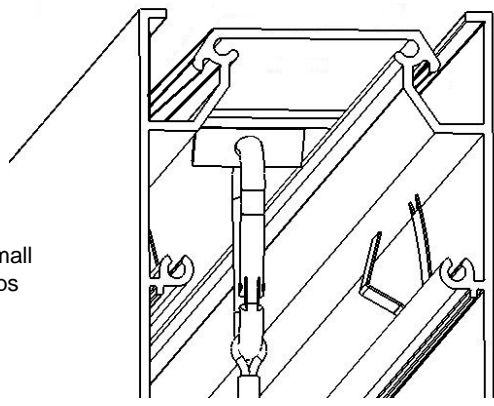
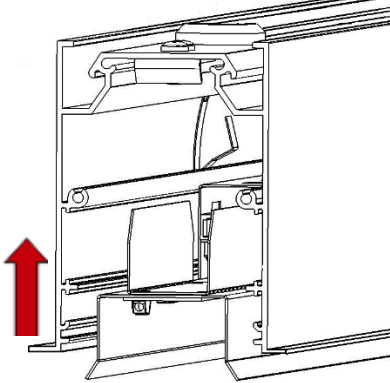
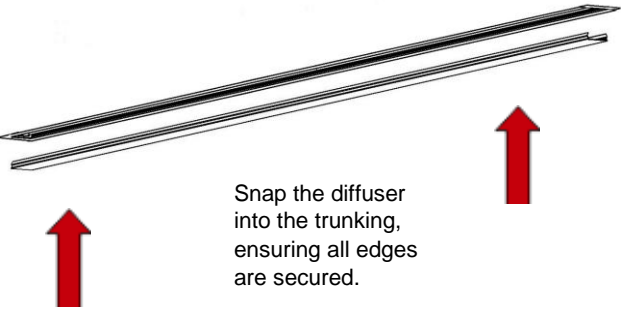
<p>15.</p> 	<p>16.</p>  <p>Close starter bracket and lock in place.</p>
<p>17.</p>  <p>Attach gear trays to tethers inside the trunking. Allow to hang naturally.</p>	<p>18.</p>  <p>Connect loom on gear tray to the loom on the starter bracket.</p>
<p>19.</p>  <p>Locate small spring clips inside trunking.</p>	<p>20.</p> <p>NOTE: SHOWN WITHOUT END CAP FOR DEMONSTRATION PURPOSES ONLY</p>  <p>Lift gear tray into extrusion. Ensure there are no cables/wires trapped when fitting.</p>
<p>21.</p>  <p>Snap the diffuser into the trunking, ensuring all edges are secured.</p>	<p>Caution:</p> <p>All red, green and blue can be run at the same time, however white can only be run with one additional colour. The fitting must not run all 4 colours at the same time. Drivers come programmed to prevent operation above 50% output when not connected to a DALI system, however commissioning will reset these values, we strongly recommend these values are programmed during commissioning to prevent overheating should the DALI system fail.</p> <p>Under no circumstances should the LEDs in this luminaire be viewed directly, only illuminate this product with the diffuser installed. Directly viewing the LEDs in this luminaire has the potential to damage eyesight.</p>