

Runway Recessed Standalone / Continuous Run

220-240V / 50-60Hz
IP20



WARNING: Luminaire must be earthed. Risk of electric shock from LED boards if operated with cover removed. Installation / operation outside of luminaires intended scope invalidates warranty. Suitable only for domestic / light industrial / industrial applications within the scope of EN55015. Tested to compliance with BSEN 60598: specification for general requirements and tests. Must be installed by a suitably qualified person in accordance with all relevant legislation. Ambient operating temperature of 0°C to 25°C. If maximum operating temperature is exceeded luminaire will automatically dim / switch off. Terminal blocks are rated to 16A unless stated otherwise. The light source contained in this luminaire shall only be replaced by the manufacturer or his service agent or a similar qualified person. **LUMINAIRES WITH EMERGENCY PACK:** When supply is isolated battery output terminals may be live if battery is connected. Isolate mains and battery before servicing. Emergency luminaires require unswitched live connection taken from same phase as switched supply. When unswitched supply is connected status indicator illuminates green, when unswitched supply is disconnected indicator extinguishes and luminaire operates in emergency mode. 24 hour charge period required before undertaking full discharge test. Emergency test sheets provided should be used to record all emergency tests. Batteries should be replaced when 3 hour duration is not met. Excessive switching of permanent live may result in premature battery failure. Battery electrolyte can be harmful to eyes / open wounds, do not puncture, if electrolyte touches skin / eyes flush with water. Do not incinerate batteries.

Terminal Labelling:	
Power	
L1	Switched Live
E	Earth
N	Neutral
Emergency	
L2	Unswitched Live
DA/AT3	DALI Autotest
DA/AT3	DALI Autotest
Dimming	
-D1/DA	Analogue/DSI/DALI
+D2/DA	Analogue/DSI/DALI
L3	Switch Dim / Corridor Function

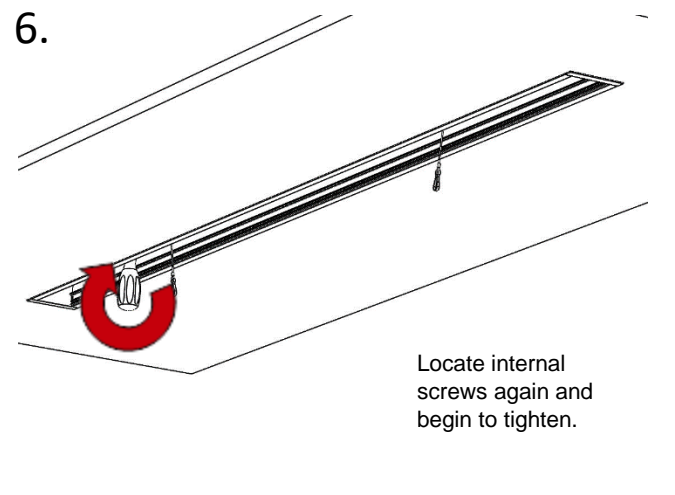
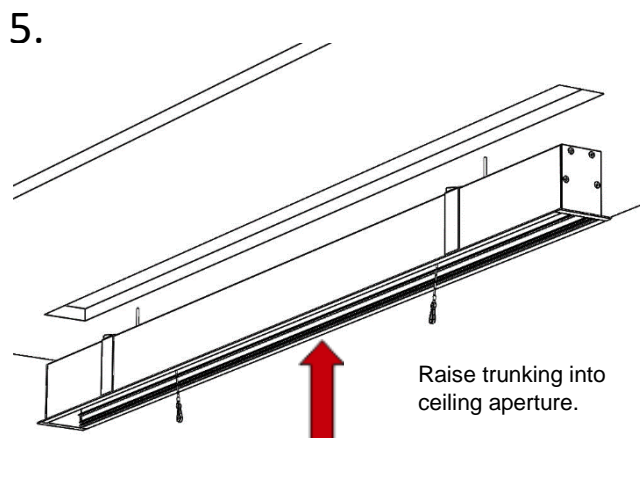
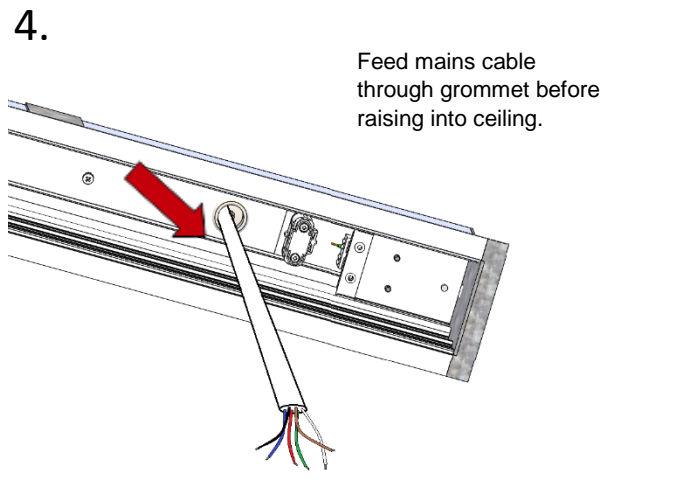
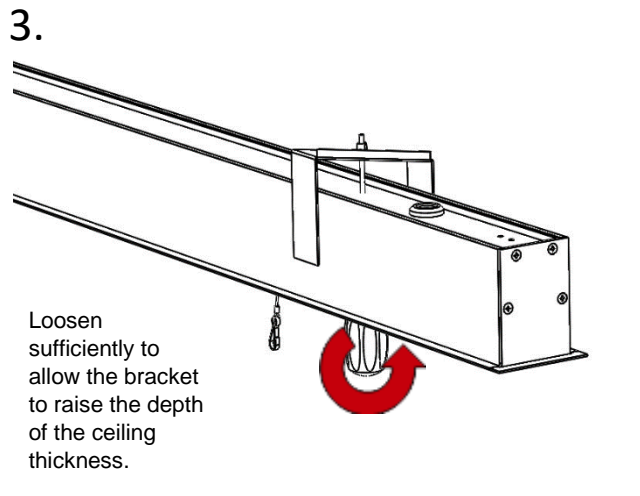
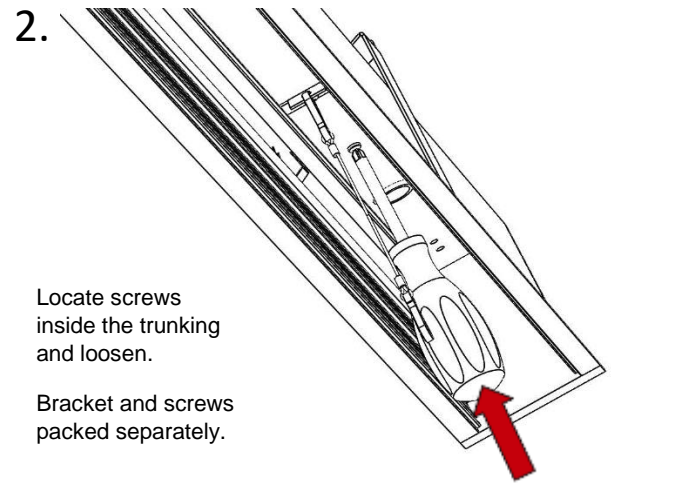
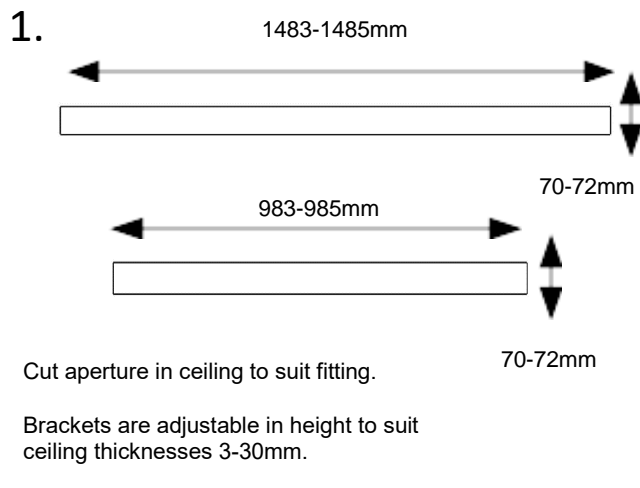

Runway Recessed Standalone / Continuous Run

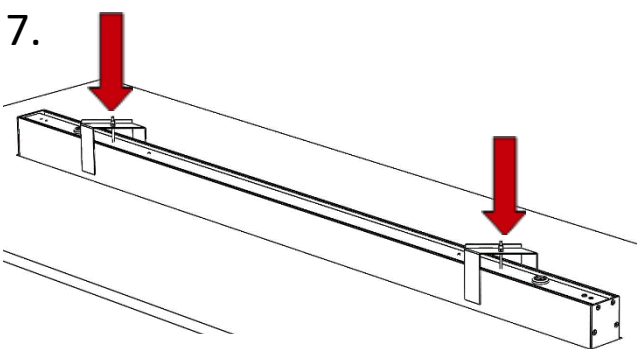
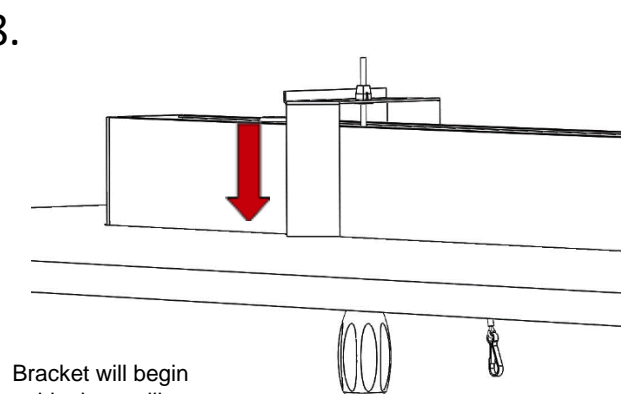
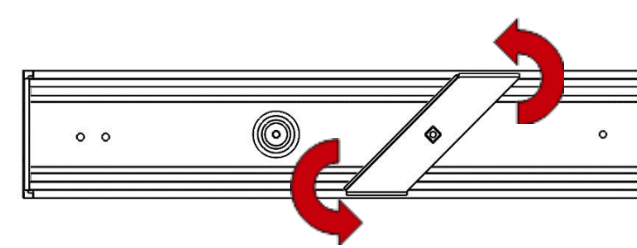
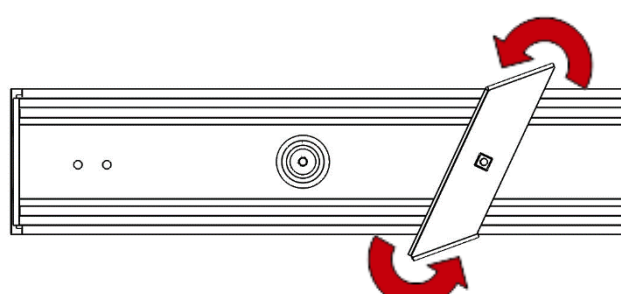
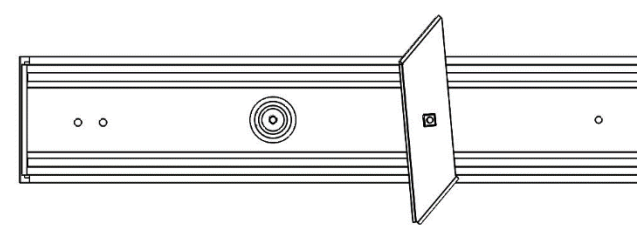
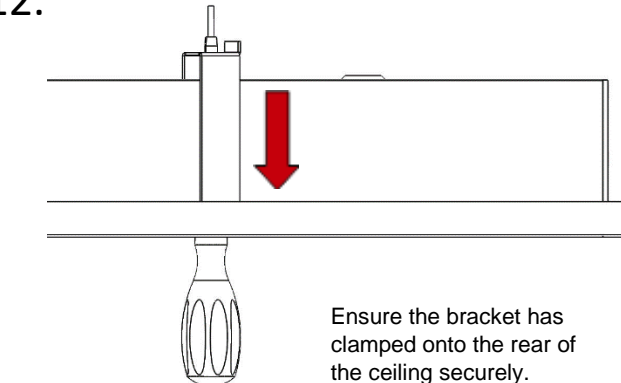
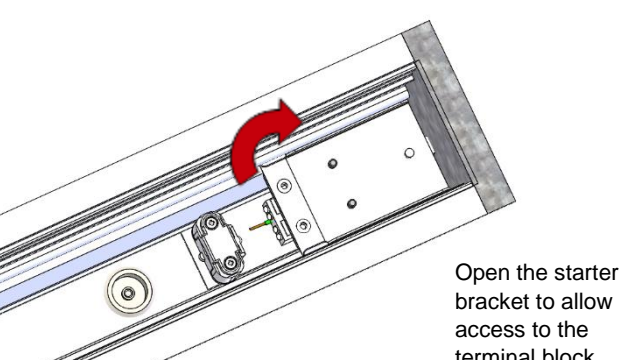
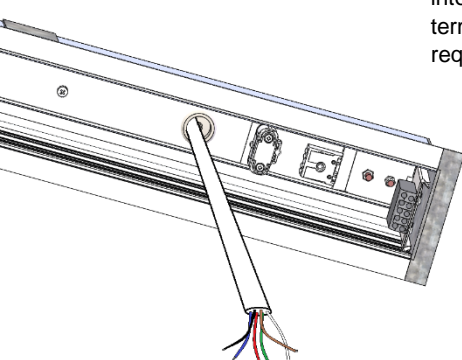
<p>7.</p>  <p>As the screws are tightened, the brackets will rotate and tighten against the rear of the ceiling.</p>	<p>8.</p>  <p>Bracket will begin to bite into ceiling.</p>
<p>9.</p>  <p>Bracket beginning to rotate.</p>	<p>10.</p>  <p>Bracket will rotate as shown as screw is tightened.</p>
<p>11.</p>  <p>Bracket fully rotated.</p>	<p>12.</p>  <p>Ensure the bracket has clamped onto the rear of the ceiling securely.</p>
<p>13.</p>  <p>Open the starter bracket to allow access to the terminal block.</p>	<p>14.</p>  <p>Wire mains cable into marked terminals as required.</p>

Runway Recessed Standalone / Continuous Run

15.

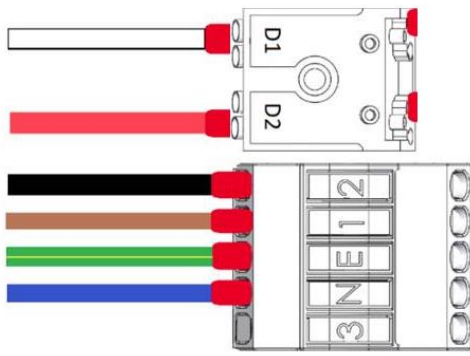

16.

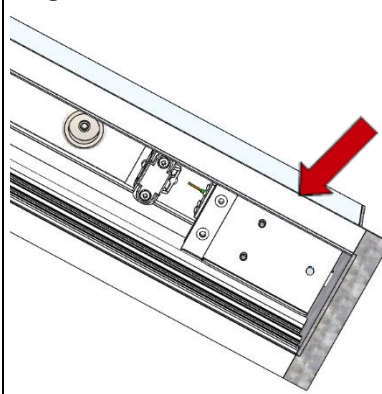

Close starter bracket and lock in place.

17.



Attach gear trays to tethers inside the trunking. Allow to hang naturally.

18.

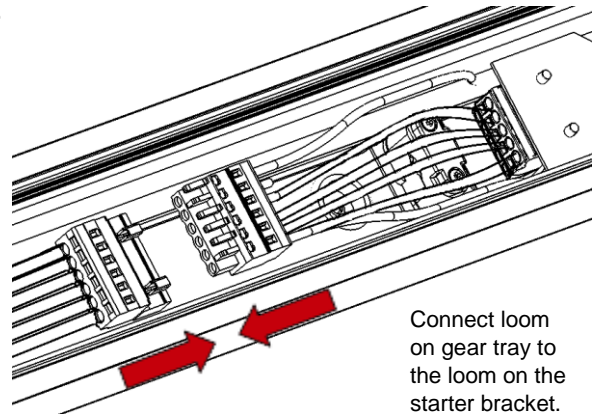

Connect loom on gear tray to the loom on the starter bracket.

19.

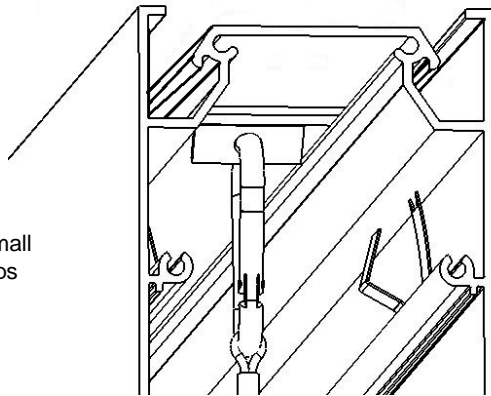

Locate small spring clips inside trunking.

NOTE: SHOWN WITHOUT END CAP FOR DEMONSTRATION PURPOSES ONLY

Lift gear tray into extrusion. Ensure there are no cables/wires trapped when fitting.

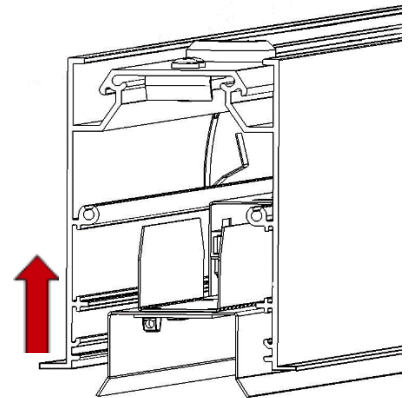

20.

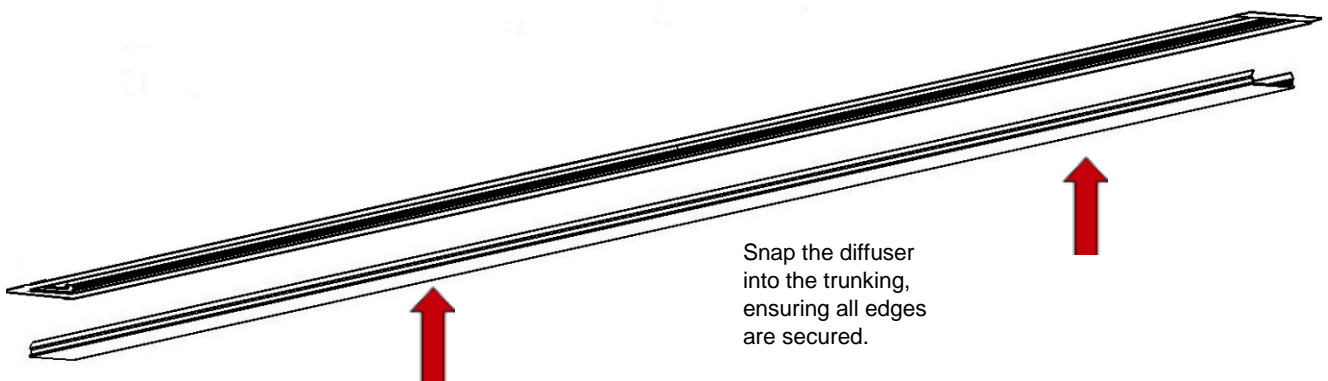

Snap the diffuser into the trunking, ensuring all edges are secured.

Runway Recessed Standalone / Continuous Run

220-240V / 50-60Hz

IP20

IK00



Terminal Labelling:

Power

L1 Switched Live
E Earth
N Neutral

Emergency

L2 Unswitched Live
DA/AT3 DALI Autotest
DALI Autotest
Dimming
-/D1/DA Analogue/DSI/DALI
+/D2/DA Analogue/DSI/DALI
L3 Switch Dim /
Corridor Function

WARNING: Luminaire must be earthed. Risk of electric shock from LED boards if operated with cover removed. Installation / operation outside of luminaires intended scope invalidates warranty. Suitable only for domestic / light industrial / industrial applications within the scope of EN55015. Tested to compliance with BSEN 60598: specification for general requirements and tests. Must be installed by a suitably qualified person in accordance with all relevant legislation. Ambient operating temperature of 0°C to 25°C. If maximum operating temperature is exceeded luminaire will automatically dim / switch off. Terminal blocks are rated to 16A unless stated otherwise. The light source is non replaceable. **LUMINAIRES WITH EMERGENCY PACK:** When supply is isolated battery output terminals may be live if battery is connected. Isolate mains and battery before servicing. Emergency luminaires require unswitched live connection taken from same phase as switched supply. When unswitched supply is connected status indicator illuminates green, when unswitched supply is disconnected indicator extinguishes and luminaire operates in emergency mode. 24 hour charge period required before undertaking full discharge test. Emergency test sheets provided should be used to record all emergency tests. Batteries should be replaced when 3 hour duration is not met. Excessive switching of permanent live may result in premature battery failure. Battery electrolyte can be harmful to eyes / open wounds, do not puncture, if electrolyte touches skin / eyes flush with water. Do not incinerate batteries.

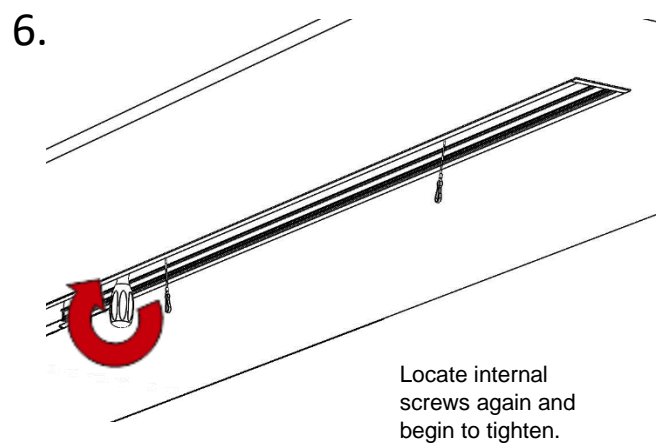
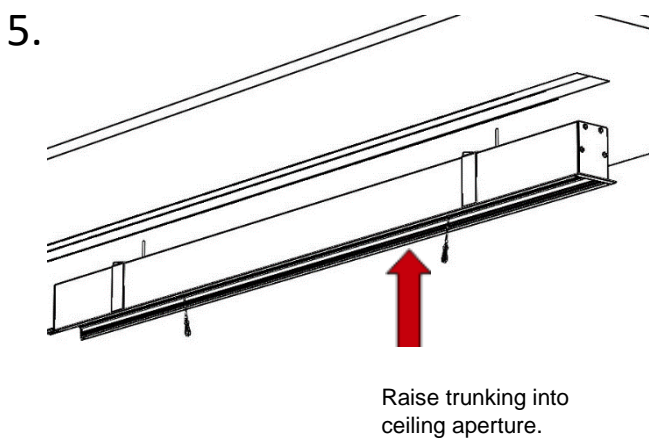
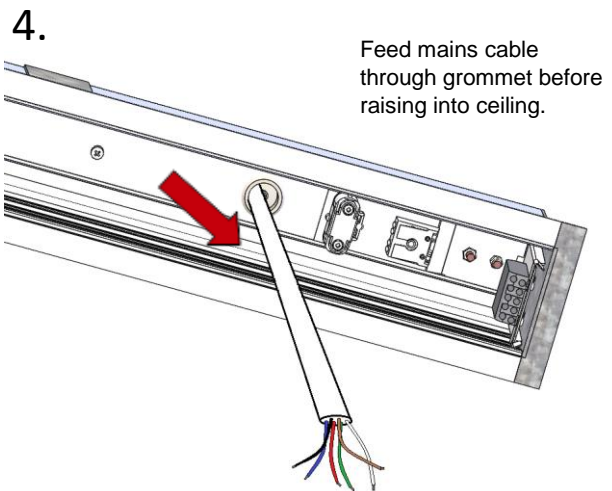
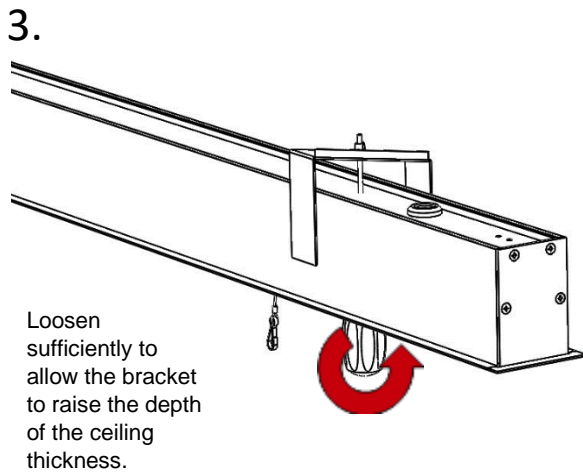
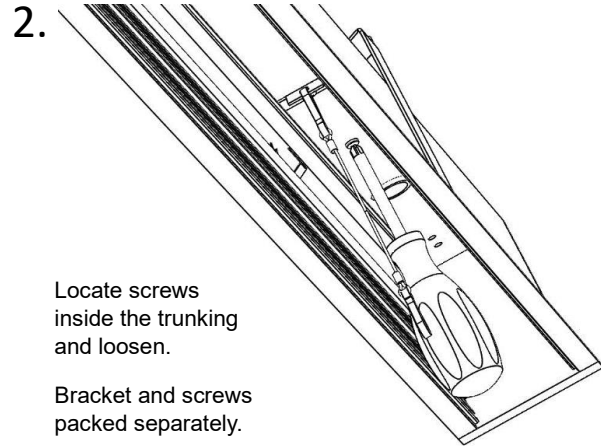
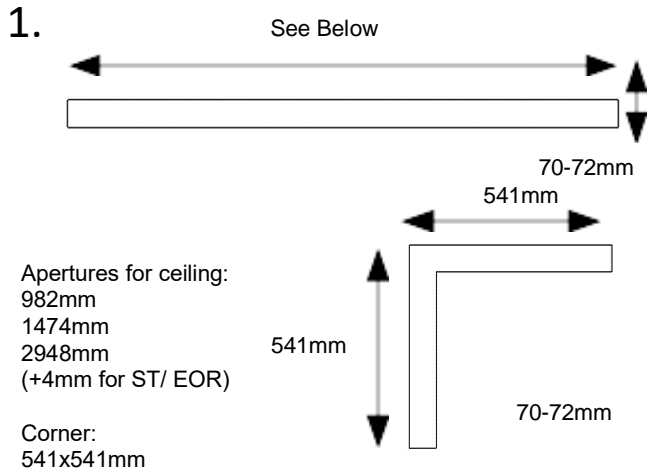

Runway Recessed Standalone / Continuous Run

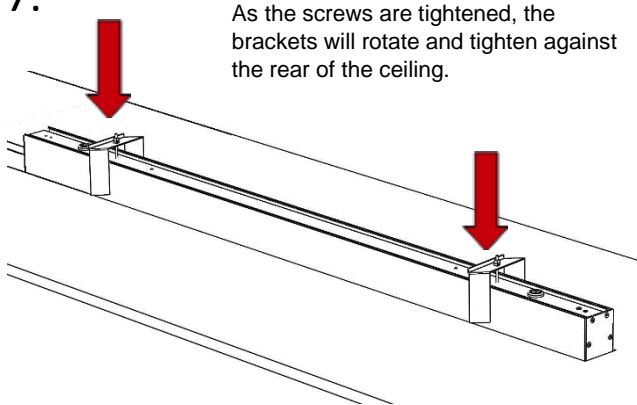
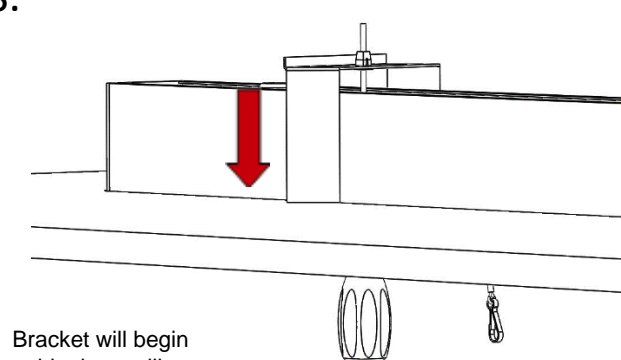
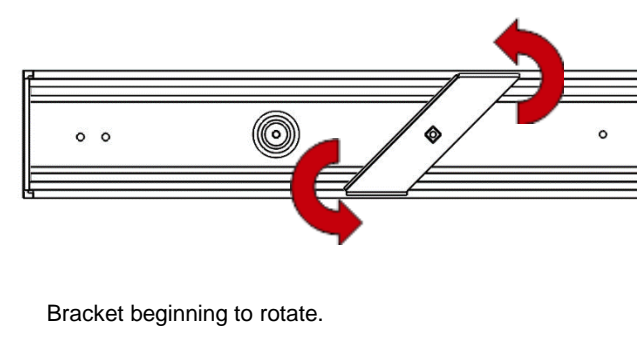
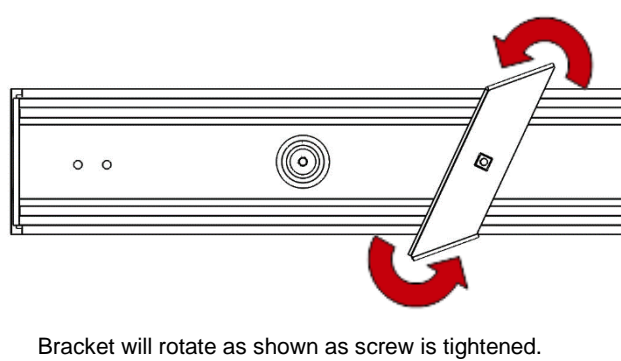
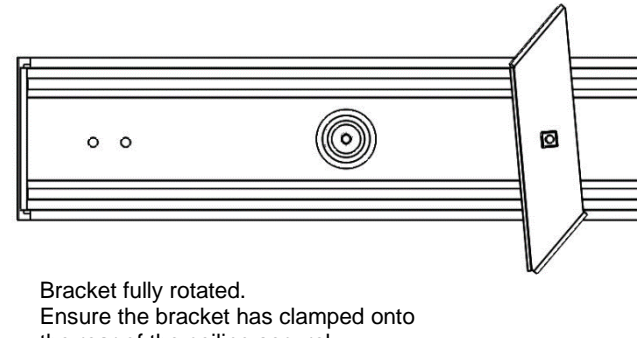
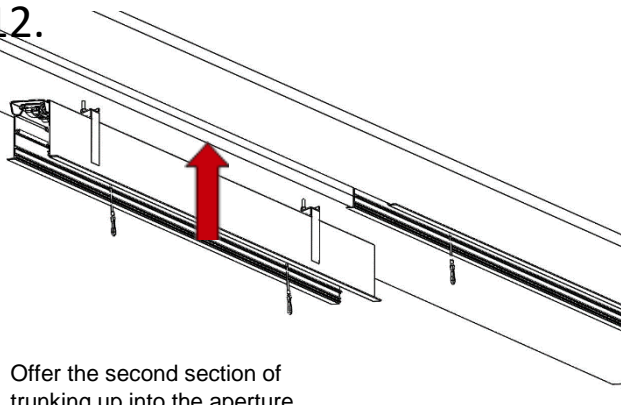
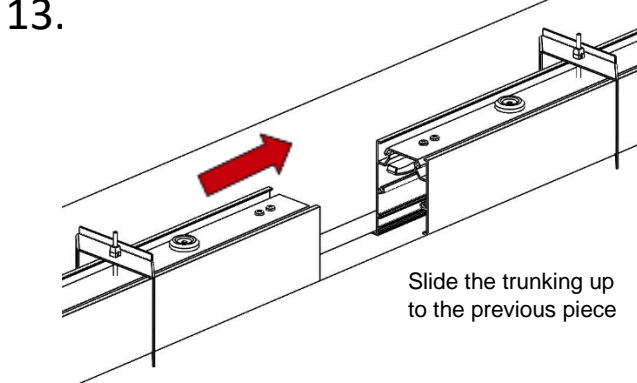
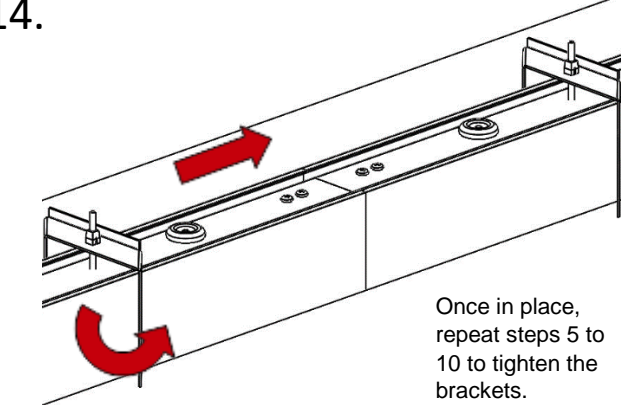
<p>7.</p>  <p>As the screws are tightened, the brackets will rotate and tighten against the rear of the ceiling.</p>	<p>8.</p>  <p>Bracket will begin to bite into ceiling.</p>
<p>9.</p>  <p>Bracket beginning to rotate.</p>	<p>10.</p>  <p>Bracket will rotate as shown as screw is tightened.</p>
<p>11.</p>  <p>Bracket fully rotated. Ensure the bracket has clamped onto the rear of the ceiling securely.</p>	<p>12.</p>  <p>Offer the second section of trunking up into the aperture</p>
<p>13.</p>  <p>Slide the trunking up to the previous piece</p>	<p>14.</p>  <p>Once in place, repeat steps 5 to 10 to tighten the brackets.</p>

Runway Recessed Standalone / Continuous Run

15.

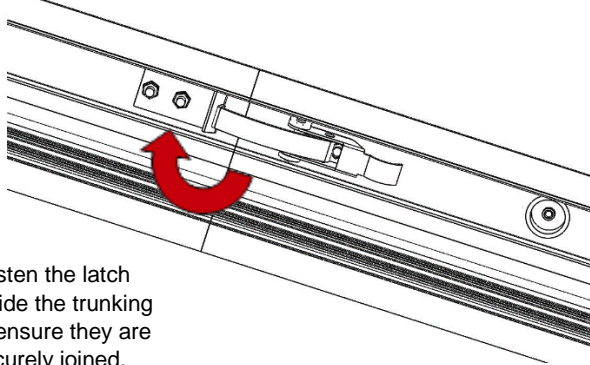

Fasten the latch inside the trunking to ensure they are securely joined.

16.

Before the end cap is fitted to the end of run trunking, the splicing plate and latch must be removed. Remove the two screws/nuts to free the latch and splice. Discard as required.

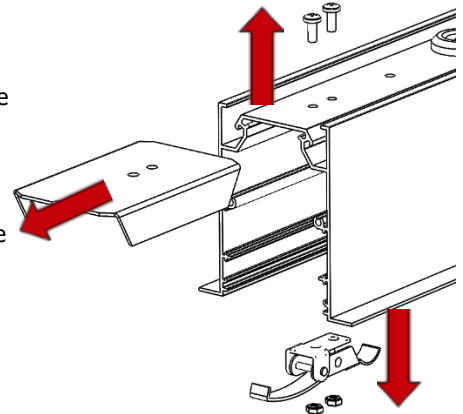

17.

Locate end caps (if required) and offer up to the end of the trunking. End cap should be fastened with 4x supplied screws.

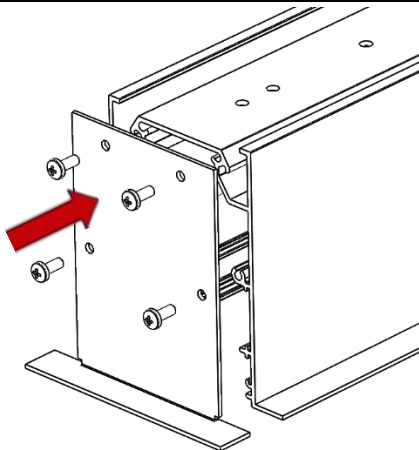

18.

Locate splicing plate into slot as shown. **PROTECTIVE GLOVES MUST BE WORN WHEN HANDLING THE PLATES.**

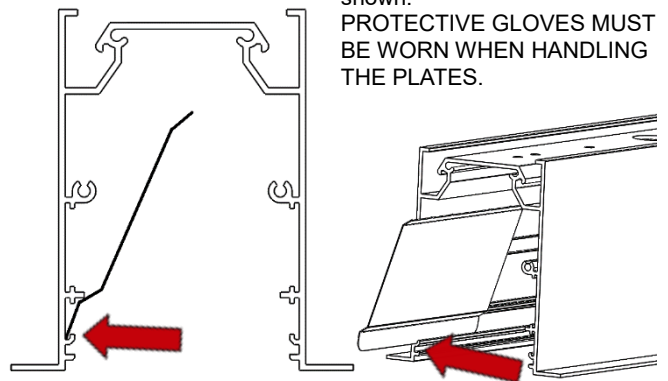

19.

Push plate towards the side wall and allow the teeth to bite into the aluminium. Repeat between all trunkings.

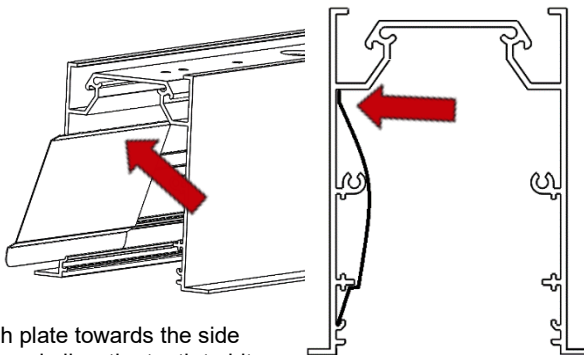

20.

Using aluminium foil light block stickers provided, attach over the plate and across the remaining join.

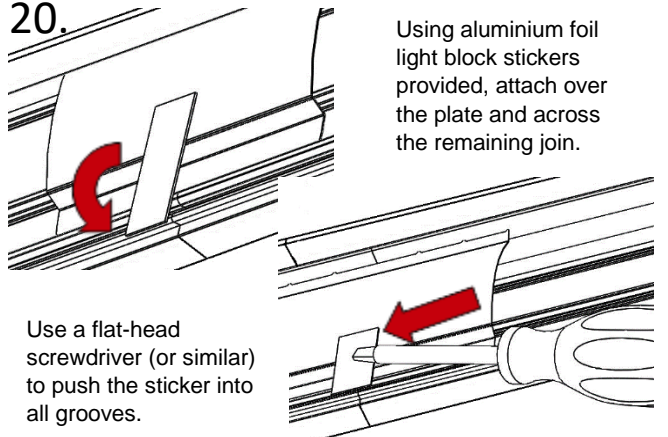

Use a flat-head screwdriver (or similar) to push the sticker into all grooves.

21.

Using a sharp knife or blade, carefully trim any excess sticker that protrudes from the bottom of the trunking.

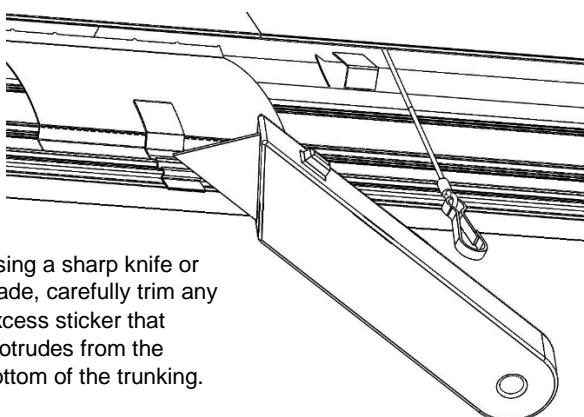

22.

Feed mains cable into marked terminals as required.

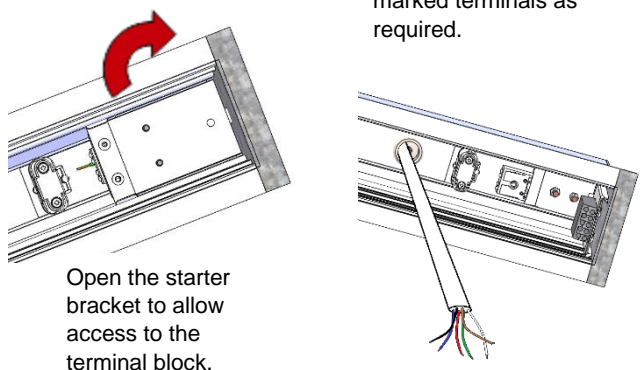

Open the starter bracket to allow access to the terminal block.

Runway Recessed Standalone / Continuous Run

23.

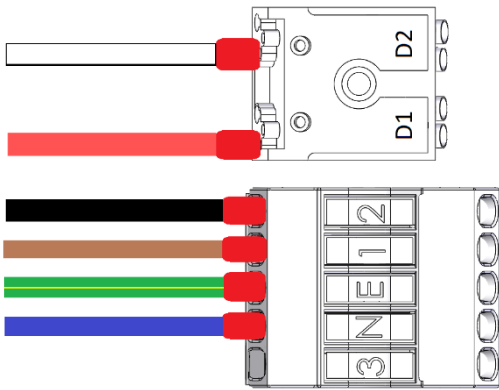

24.

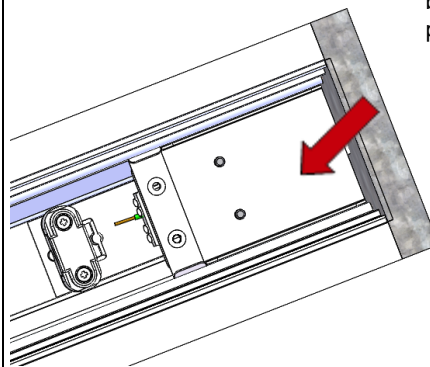

Close starter bracket and push in to place.

25.

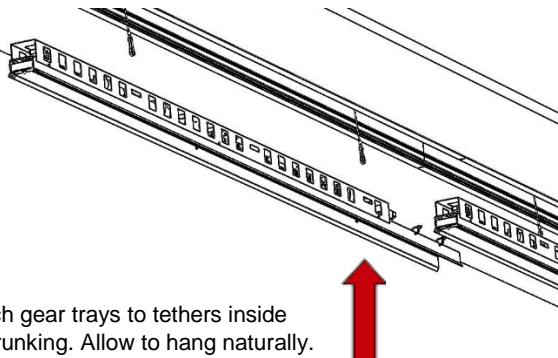

Attach gear trays to tethers inside the trunking. Allow to hang naturally.

26.

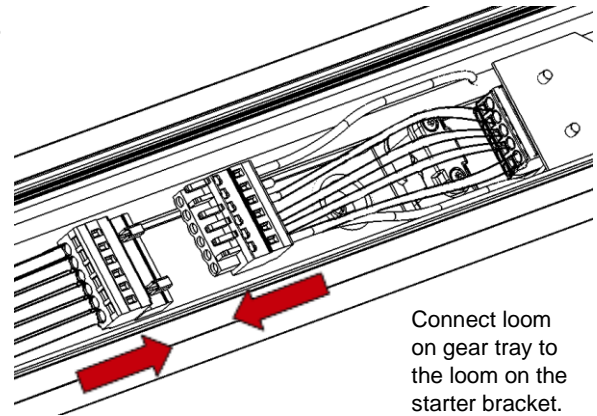

Connect loom on gear tray to the loom on the starter bracket.

27.

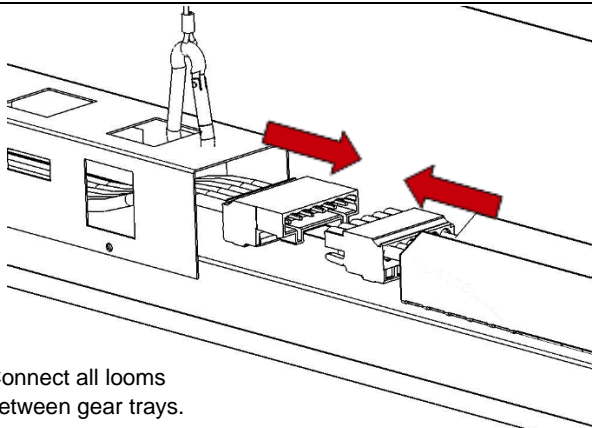

Connect all looms between gear trays.

28.

NOTE: SHOWN WITHOUT END CAP FOR DEMONSTRATION PURPOSES ONLY

Raise gear trays into trunking and engage on spring clips.

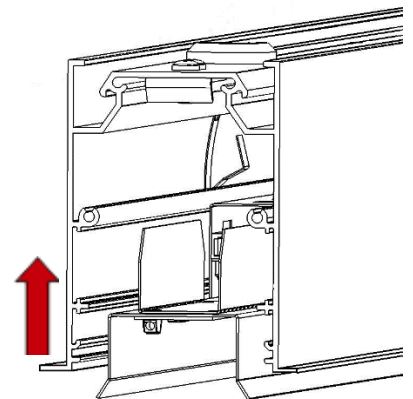

29.

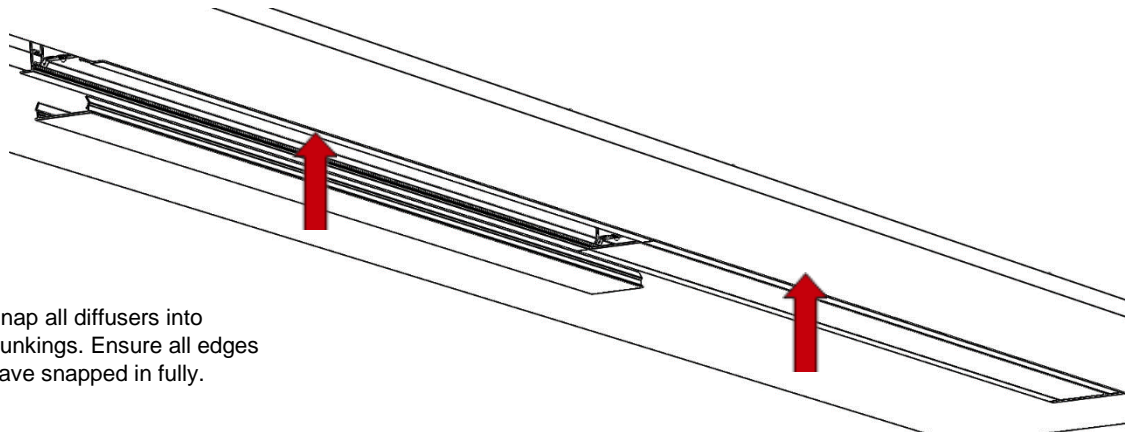

Snap all diffusers into trunkings. Ensure all edges have snapped in fully.

Runway Recessed Standalone / Continuous Run

Maintenance

- 1 Disconnect luminaire before undertaking any maintenance or cleaning.
- 2 Cleaning should be undertaken on external parts of the luminaire only using a slightly damp lint free cloth.
- 3 Use a flat headed screwdriver to remove diffuser.
- 4 Remove gear tray from housing.
- 5 Remove plastic rivets to separate the two trays.
- 6 Use a pan pozi screwdriver to remove components.
- 7 Please contact Dextra for assistance with spare component supply.

